



800-336-4864

tele-movers.com

NEC



LEVEL I

INSTALLATION SERVICE MANUAL

June 1998

NEC America, Inc.

ND-021203

Issue 5

Contents of this manual are subject to change without prior notice at the discretion of NEC America, Inc. This document has been prepared for the use of employees and customers of NEC America, Inc. and may not be reproduced without prior written approval of NEC America, Inc.

Copyright 1998

**NEC America, Inc.
1555 Walnut Hill Lane
Irving, TX 75038**

Business Terminal Division

PREFACE

THIS MANUAL

This Installation Service Manual provides the information required to install, program, and maintain the Electra Professional Level I system.

This manual is divided into three chapters as follows:

Chapter 1: Hardware Installation

Chapter 1 provides the information required to prepare and install the system, including applicable FCC requirements and UL regulatory information.

Chapter 2: Programming

Chapter 2 provides detailed instructions for performing System Programming.

Chapter 3: System Maintenance

Chapter 3 provides maintenance instructions and flowcharts for the system.

Chapter 4: Electra Professional Level I, Level II, and Level II Advanced Electra Elite Terminal Upgrade

Chapter 4 provides instructions for upgrading the Electra Professional system to use Electra Elite Multiline Terminals.

SUPPORTING DOCUMENTS

In addition to the Installation Service Manual, the Electra Professional Level I system is supported by the following technical manuals:

Electra Professional Level I General Description Manual (Stock Number 722000)

Designed and developed to provide a general overview of the Electra Professional Level I system, its features, configuration, service features, specifications, and standards.

Electra Professional Level I Features and Specifications Manual (Stock Number 722001)

Provides an expanded discussion of each feature that is available to the Electra Professional Level I system. In addition, the Features and Specifications Manual provides Station Application, Operating Procedures, and Service Conditions.

Electra Professional Level I Station Operations Manual (Stock Number 722003)

This manual explains in detail the station operations for all station user features. This manual is designed for use by installers and end users.

Electra Professional Level I Job Specifications Manual (Stock Number 722004)

Used in conjunction with the Installation Service Manual, the Job Specifications Manual is designed for the service technicians who are responsible for planning the system installation, maintaining the system, and keeping records of system programming and configuration. (This manual is included with every ESF-C-10 KSU.)

CHAPTER 1

HARDWARE SPECIFICATIONS

AND INSTALLATION

TABLE OF CONTENTS

SECTION 1	SYSTEM SUMMARY	1-1
1.1	Introduction	1-1
1.2	Regulatory Information	1-1
1.2.1	Company Notification	1-2
1.2.2	Industry Canada (IC) Requirements	1-2
1.2.3	Battery Disposal	1-3
1.2.4	Incidence of Harm	1-4
1.2.5	Radio Frequency Interference	1-4
1.2.6	Hearing Aid Compatibility	1-4
1.2.7	Service Requirements	1-4
1.2.8	UL Regulatory Information	1-5
1.3	List of Abbreviations	1-5
1.4	System Configuration Drawing	1-6
1.5	Equipment List	1-7
1.6	Equipment General Information	1-8
1.7	Equipment Description	1-9
1.7.1	Key Service Units and Power Supply Units	1-9
1.7.2	Station Interface Key Telephone Unit	1-9
1.7.3	Trunk Interface Key Telephone Unit	1-9
1.7.4	Optional Key Telephone Units	1-9
1.7.5	Electra Elite Digital Multiline Terminals, Electra Professional Multiline Terminals, Single Line Telephones, and Associated Equipment	1-10
1.7.6	Single Line Telephone Adaptors	1-12
1.7.7	Doorphone Equipment	1-12
SECTION 2	SYSTEM SPECIFICATIONS	1-12
2.1	General Information	1-12
2.2	System Block Diagram	1-12
2.3	System Control Capacities	1-14

2.4	Cabling Requirements	1-14
2.4.1	Cabling Specifications	1-14
2.4.2	Cabling Precautions	1-16
2.5	Power Requirements	1-16
2.5.1	Power Supply Inputs	1-16
2.5.2	Power Supply Outputs	1-16
2.5.3	Power Consumption and Dissipation	1-16
2.5.4	Fuse Replacement	1-17
2.6	Environmental Conditions	1-17
2.7	Outside Line Types	1-17
2.8	Network and Control Specifications	1-17
2.8.1	Transmission	1-17
2.8.2	Network	1-17
2.8.3	Control	1-18
2.9	Dialing Specifications	1-18
2.9.1	Dial Pulse Address Signaling	1-18
2.9.2	DTMF Address Signaling	1-18
2.10	Battery Backup	1-19
2.10.1	System Backup	1-19
2.10.2	Memory Backup	1-19
2.10.3	Battery Backup - Full System Power	1-20
2.11	Weights and Dimensions	1-21
2.12	External Equipment Interface	1-22
2.12.1	Music On Hold (c)	1-22
2.12.2	Station Message Detail Recording (SMDR)	1-22
2.12.3	External Paging	1-22
2.12.4	General Purpose Relays	1-22
2.13	Visual and Audible Indications	1-23
2.13.1	Tone Patterns Table	1-23

2.13.2	Multiline Terminal Flash Patterns Table	1-24
2.13.3	DSS/BLF LED Indications Table	1-25
SECTION 3	HARDWARE REQUIREMENTS.	1-25
3.1	General Information.	1-25
3.1.1	Programming Stations.	1-25
3.1.2	Attendant Stations.	1-25
3.2	Determining Required Equipment	1-26
3.2.1	Station Equipment.	1-26
3.2.2	Interface KTUs	1-26
3.2.3	PBR Requirements	1-28
3.3	Installation Example	1-28
SECTION 4	KSU Installation	1-29
4.1	General Information.	1-29
4.2	Site Preparation and MDF/IDF Construction	1-29
4.2.1	Precautionary Information	1-29
4.2.2	Site Survey	1-29
4.2.3	Site Limitations.	1-29
4.2.4	Site Selection Conditions	1-30
4.2.5	MDF Construction	1-30
4.3	Installing the Key Service Unit (KSU)	1-31
4.3.1	Installation Precautions.	1-31
4.3.2	KSU	1-31
4.3.3	Removing the KSU Cover	1-33
4.3.4	Wall Mounting the KSU	1-33
4.3.5	Battery Installation	1-35
4.3.5.1	Removing the Built-In Batteries.	1-35
4.3.5.2	Replacing the Built-In Batteries	1-37
4.3.5.3	Connection External Batteries	1-37
4.3.5.4	Replacing the Battery for System Memory	1-38
4.3.6	Grounding Requirements	1-39

SECTION 5	INSTALLING A KEY TELEPHONE UNIT (KTU).....	1-39
5.1	General Information.....	1-39
5.1.1	Installation Precautions.....	1-39
5.1.2	KTU Installation.....	1-40
5.1.3	Mounting the KTUs.....	1-40
5.1.4	Installing COI-C(2)-10 KTU/ COI-C(2A)-10 KTU.....	1-40
5.1.4.1	Installing COI-C(2)-10 KTU.....	1-40
5.1.4.2	Installing COI-C(2A)-10 KTU.....	1-41
5.2	Common Control KTU.....	1-42
5.3	Interface KTUs.....	1-45
5.3.1	ESI-C(8)-11 KTU.....	1-45
5.3.2	COI-C(2)-10 KTU/ COI-C(2A)-10 KTU.....	1-45
5.3.2.1	COI-C(2)-10 KTU.....	1-45
5.3.2.2	COI-C(2A)-10 KTU.....	1-45
5.4	Optional KTUs.....	1-47
5.4.1	VRS-C(1)-11 KTU.....	1-47
5.4.2	PBR-C(4)-11 KTU.....	1-47
5.4.3	SMDR-C-10 KTU.....	1-48
5.4.4	Installing the FAX-C(1)-11 KTU.....	1-50
5.5	Power Failure Backup.....	1-51
5.5.1	Operation if Power Fails.....	1-51
5.5.2	Operation When Input Power is Restored.....	1-53
5.5.3	Single Line Telephone for Power Failure Transfer.....	1-53
5.5.3.1	Connections.....	1-53
5.5.3.2	Procedure.....	1-54
SECTION 6	CABLE CONNECTIONS.....	1-54
6.1	General Information.....	1-54
6.1.1	Connection Requirements.....	1-54
6.1.2	Cabling Precautions.....	1-54

6.2	Wiring Between the KSU and the MDF	1-54
6.2.1	KSU Cables	1-54
6.2.1.1	Modular Terminal Connections	1-57
6.2.1.2	Single Line Telephone Connections	1-58
6.2.2	KSU Cable Routing	1-59
6.2.3	Outside Lines	1-59
SECTION 7	TERMINAL INSTALLATIONS.....	1-60
7.1	General Information	1-60
7.2	Digital Multiline Terminals	1-60
7.2.1	DTU-8-() (BK)/(WH) TEL	1-60
7.2.2	DTU-16-() (BK)/(WH) TEL	1-61
7.2.3	DTU-16D-() (BK)/(WH) TEL.....	1-62
7.2.4	DTU-32-() (BK)/(WH) TEL	1-62
7.2.5	DTU-32D-() (BK)/(WH) TEL.....	1-63
7.2.6	Adjusting the LCD	1-64
7.2.7	Line Card and Plastic Panel Installation	1-65
7.3	Electra Professional Multiline Terminals	1-66
7.3.1	ETW-8-1 (BK)/(SW) TEL	1-66
7.3.2	ETW-16DC-1 (BK)/(SW) TEL	1-67
7.3.3	ETW-16DD-1 (BK)/(SW) TEL	1-67
7.3.4	Connecting a Multiline Terminal to the System	1-68
7.3.5	Installing the Plastic Panel on a Multiline Terminal	1-68
7.3.6	Tilt Stand Adjustment	1-70
7.4	SLT-F(1G)-() ADP	1-71
7.4.1	Connection	1-71
7.4.2	Wall Mounting the SLT-F(1G)-() ADP	1-73
7.5	Wall Mounting Units	1-74
7.5.1	General	1-74
7.5.2	Install the Electra Elite WMU-U Unit	1-74
7.5.3	Install the Electra Professional WMU-W Unit	1-79

SECTION 8	ANCILLARY DEVICE CONNECTION.....	1-81
8.1	General Information.....	1-81
8.2	Install the Electra Elite ADA-U Unit.....	1-81
8.2.1	Install an ADA-U Unit on a Digital Multiline Terminal.....	1-81
8.2.2	Connecting Cables to the ADA-U Unit.....	1-84
8.3	Install the Ancillary Device Adaptor Unit [ADA(1)-W (BK)/(SW) or ADA(2)-W (BK)/(SW) in the Multiline Terminal.....	1-88
8.4	Install the APR-U Unit.....	1-90
8.4.1	Install an APR-U Unit on a Digital Multiline Terminal.....	1-91
8.4.2	Switch Settings.....	1-94
8.5	Install the HFU-U Unit.....	1-95
8.5.1	Installing an HFU-U Unit on a Digital Multiline Terminal.....	1-96
SECTION 9	OPTIONAL EQUIPMENT CONNECTION.....	1-98
9.1	General Information.....	1-98
9.2	Music On Hold/Background Music.....	1-98
9.3	External Paging.....	1-99
9.4	Installing Peripherals.....	1-100
9.5	External Ring Control/Night Chime.....	1-100
9.6	Doorphones/Door Lock Releases.....	1-101
9.7	Video Doorphone.....	1-102
SECTION 10	LCD INDICATIONS TABLE.....	1-103
SECTION 11	FEATURE ACCESS CODES.....	1-107

LIST OF FIGURES

1-1	Outside View of the Electra Professional Level I KSU	1-1
1-2	System Configuration Drawing (Example)	1-6
1-3	System Block Diagram	1-13
1-4	Connecting the ESI to the Multiline Terminal Using Twisted 2-Pair Cable.	1-15
1-5	Full Capacity KSU	1-27
1-6	Typical Full MDF Layout	1-31
1-7	Front View of a Fully Loaded KSU	1-32
1-8	Removing the KSU Cover	1-33
1-9	Attaching the Wall Mount Bracket for the KSU to the Wall	1-33
1-10	Attaching the KSU to the Wall Mount Template	1-34
1-11	Securing the KSU to the Wall Mount Template	1-34
1-12	Removing Batteries.	1-35
1-13	Removing the Battery Cables	1-36
1-14	Disconnecting Built-in Batteries.	1-37
1-15	Connecting External Batteries	1-37
1-16	Lithium Battery Location	1-38
1-17	Replacing Lithium Battery	1-38
1-18	KSU Grounding	1-39
1-19	Installing a Vertically Mounted KTU	1-40
1-20	Installing COI-C(2)-10 KTU	1-41
1-21	Installing COI-C(2A)-10 KTU	1-42
1-22	KSU Switch Settings	1-43
1-23	ESI-C(8)-11 KTU	1-45
1-24	COI-C(2)-10 KTU	1-46
1-25	COI-C(2A)-10 KTU	1-46
1-26	VRS-C(1)-11 KTU	1-47
1-27	PBR-C(4)-11 KTU	1-48
1-28	SMDR-C-10 KTU Cable	1-49

1-29	SMDR-C-10 KTU Switch Layout	1-49
1-30	FAX-C(1)-11 KTU Installation.	1-50
1-31	Fax Connection.	1-51
1-32	Power Failure Backup Flowchart	1-52
1-33	Connecting a Single Line Telephone for Power Failure Transfer	1-53
1-34	Cable Assembly Diagram.	1-56
1-35	Modular Terminal for Connection of Multiline Terminals and SLT Adaptor	1-57
1-36	Modular Terminal for Connection of ETW Multiline Terminals and SLT Adaptor. . .	1-57
1-37	Simplified Single Line Telephone Connection.	1-58
1-38	KSU Cable Routing	1-59
1-39	Connecting CO/PBX Lines.	1-60
1-40	DTU-8-() (BK)/(SW) TEL Multiline Terminal.	1-61
1-41	DTU-16-() (BK)/(WH) TEL	1-61
1-42	DTU-16D-() (BK)/(WH) TEL.	1-62
1-43	DTU-32-() (BK)/(WH) TEL	1-63
1-44	DTU-32D-() (BK)/(WH) TEL.	1-64
1-45	Adjusting the LCD	1-64
1-46	Installing Line Card and Plastic Panel on a Multiline Terminal.	1-65
1-47	Removing the Plastic Panel from the Multiline Terminal	1-66
1-48	ETW-8-1 (BK)/(SW) TEL Multiline Terminal.	1-66
1-49	ETW-16DC-1 (BK)/(SW) TEL Multiline Terminal.	1-67
1-50	ETW-16DD-1 (BK)/(SW) TEL Multiline Terminal.	1-67
1-51	Connecting a Multiline Terminal to the System	1-68
1-52	Installing the Designation Card, Plastic Panel, and Labels on a Multiline Terminal . .	1-69
1-53	Unfolding the Legs of the Tilt Stand	1-70
1-54	Folding the Legs of the Tilt Stand	1-70
1-55	SLT-F(1G)-() ADP.	1-71
1-56	Connecting a Single Line Telephone Using the SLT-F(1G)-() ADP.	1-72
1-57	Removing the Screws from the Cover of the SLT-F(1G)-() ADP.	1-73

1-58	Attaching the SLT-F(1G)-() ADP to the Wall	1-73
1-59	Positioning the Handset Hanger	1-74
1-60	Removing the Base Unit	1-75
1-61	Removing the Knockout	1-75
1-62	Attaching the Base Unit to the Wall	1-76
1-63	Wall Mounting Using a Modular Jack	1-76
1-64	Plugging in the Line Cord Using a Wall Jack	1-77
1-65	Plugging in the Line Cord Using a Modular Jack	1-77
1-66	Attaching the Bottom Tabs of the Digital Multiline Terminal to the Base Unit	1-78
1-67	Attaching the Top Tabs of the Digital Multiline Terminal to the Base Unit	1-78
1-68	Installed Wall Mount Unit	1-79
1-69	Wall Mounting Preparation	1-79
1-70	Mounting the WMU-W (BK)/(SW) Unit to the Wall	1-80
1-71	Mounting the Multiline Terminal to the WMU-W (BK)/(SW) Unit	1-80
1-72	Remove the Tilt Panel on the Digital Multiline Terminal	1-82
1-73	Unlatch the Cover on the Digital Multiline Terminal	1-82
1-74	Open the Cover on the Digital Multiline Terminal	1-83
1-75	Attach the ADA-U Unit to the Digital Multiline Terminal	1-83
1-76	Lead the Telephone Cord Out from the ADA-U Unit	1-84
1-77	ADA-U Unit	1-84
1-78	Attach Cables to the ADA-U Unit	1-85
1-79	ADA-U Unit Switch Settings	1-87
1-80	Remove the Knockouts to Install ADA(1)-W (BK)/(SW) Unit or ADA(2)-W (BK)/(SW) Unit	1-89
1-81	ADA(1)-W (BK)/(SW) Unit or ADA(2)-W (BK)/(SW) Unit Installation	1-89
1-82	APR-U Unit	1-90
1-83	Raise the Tilt Panel	1-91
1-84	Unlatch the Cover on the Digital Multiline Terminal	1-91
1-85	Attach the Unit to the Digital Multiline Terminal	1-92
1-86	Lead the AC Adapter Cord out from the Unit	1-92

1-87	Close the Tilt Panel Cover	1-93
1-88	Ferrite Core Installation	1-93
1-89	APR-U Unit Switches.....	1-94
1-90	HFU-U Unit	1-95
1-91	Microphone with Mute	1-96
1-92	Attach Microphone to Digital Multiline Terminal	1-96
1-93	MOH/BGM Cable Shield Ground Exposed	1-98
1-94	External Amplifier with Control Terminal	1-99
1-95	External Paging with Background Music	1-100
1-96	External Ring Control/Night Chime	1-100
1-97	Doorphones with Door Lock Release	1-101
1-98	Video Doorphone	1-102

LIST OF TABLES

1-1	List of Abbreviations	1-5
1-2	KSU and PSU	1-7
1-3	Station Interface KTU.....	1-7
1-4	Trunk Interface KTU	1-7
1-5	Other Optional KTUs	1-7
1-6	Electra Professional Level I Terminals.....	1-8
1-7	Single Line Telephone Adaptor	1-8
1-8	Doorphone Equipment	1-8
1-9	System Control Capacities	1-14
1-10	Multiline Terminal Loop Resistance and Cable Length	1-15
1-11	Single Line Telephone Connection Cable Length	1-15
1-12	Power Outputs.....	1-16
1-13	Fuse Replacement.....	1-17
1-14	KTU Battery Backup Time.....	1-19
1-15	Weights and Dimensions.....	1-21
1-16	Tone Patterns.....	1-23
1-17	Multiline Terminal LED Flash Patterns	1-24
1-18	DSS/BLF LED Indications	1-25
1-19	Number of Required Interface KTUs	1-28
1-20	System Configuration Example	1-28
1-21	KSU Adjustments	1-44
1-22	SMDR and Printer Connections	1-49
1-23	Connection Information/Connection and Port Relationships	1-55
1-24	ADA-U Cable Connection	1-86
1-25	ADA-U Unit Switch Settings	1-88
1-26	ADA(1)-W (BK)/(SW) Unit or ADA(2)-W (BK)/(SW) Cable Connection	1-90
1-27	APR-U Unit Switch Settings for SW1 and SW3	1-94
1-28	HFU-U Unit Switch Settings	1-97
1-29	LCD Indications Table	1-103
1-30	Access Code Tables	1-108

CHAPTER 1

HARDWARE SPECIFICATIONS AND INSTALLATION

SECTION 1 SYSTEM SUMMARY

1.1 Introduction

The Electra Professional Level I is a fully digital telephone system serving a maximum of eight outside (CO/PBX) lines and 16 stations. The system provides for flexible configuration, allowing the customer to purchase only what is needed. The Basic Key Service Unit (KSU) can accommodate a combined total of four CO lines and eight stations. As customer business grows, the system can be expanded to accommodate a combined total of eight CO/PBX lines and 16 stations. Additional equipment such as Single Line Telephones, external speakers, Voice Mail, or facsimile machines can be connected to the system to enhance the capabilities of the system. [Figure 1-1 - Outside View of the Electra Professional Level I KSU and Figure 1-2 - System Configuration Drawing (Example) provide diagrams of the available system configurations.]

This chapter provides the technician, installing the system, a comprehensive explanation of the Electra Professional Level I specifications, hardware, and installation procedures. The technician should read this entire chapter before installing the system to enable a more efficient installation.

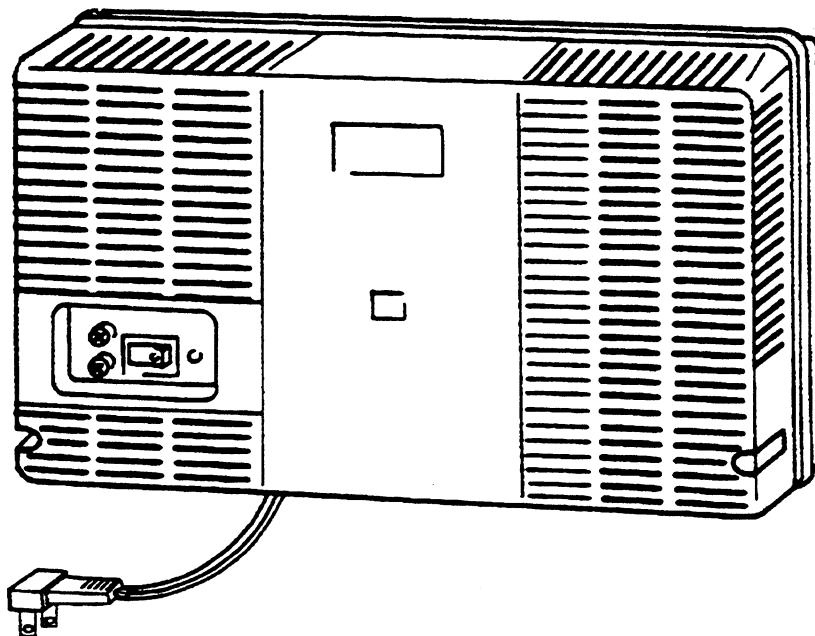

Figure 1-1 Outside View of the Electra Professional Level I KSU

1.2 Regulatory Information

The Federal Communications Commission (FCC) has established rules that permit this telephone system to be directly connected to the telephone network. A jack is provided by the telephone company. Jacks for this type of customer provided equipment will not be provided on party lines or coin lines.

The telephone company may make changes in its technical operations and procedures. If such changes affect the compatibility or use of the Electra Professional Level I, the telephone company is required to give adequate notice of the changes.

1.2.1 Company Notification

Before connecting this telephone system to the telephone network, the following information must be provided to the telephone company:

1. Your telephone number.
2. FCC registration number:
 - If the system is to be installed as a Key System (no dial access to outside lines), use the following number:
AY5THA-74138-KF-E
 - If the system is to be installed as a Multi-Function System, use the following number:
AY5THA-74139-MF-E
3. Ringer Equivalence Number: 2.0B
4. USOC jacks required: RJ11C, RJ21X
5. Facility Interface Code: 02LS2

1.2.2 Industry Canada (IC) Requirements

Industry Canada (IC) has established rules that permit this telephone system to be directly connected to the telephone network. Prior to the connection or disconnection of this telephone system to or from the telephone network, the telephone company must be provided with the following information.

1. Your telephone number.
2. IC registration number: 140 5053 A
3. The Load Number of the equipment: 9

The Industry Canada label identifies certified equipment. This certification means that the equipment meets certain telecommunications network protective operational and safety requirements. Industry Canada does not guarantee the equipment will operate to user 's satisfaction.

Before installing this equipment, users should ensure that it is permissible to be connected to the facilities of the local telecommunications company. The equipment must also be installed using an acceptable method of connection. In some cases, the company's inside wiring associated with a single line individual service may be extended using a certified connector assembly (telephone extension cord). The customer should be aware that compliance with the above conditions may not prevent degradation of service in some situations.

Repairs to certified equipment should be made by an authorized Canadian maintenance facility designated by the supplier. Any repairs or alterations made by the user to this equipment, or equipment malfunctions, may give the telecommunications company cause to request the user to disconnect the equipment.

Users should ensure for their own protection that the electrical ground connections of the power utility, telephone lines, and internal metallic water pipe system, if present, are connected together. This precaution may be particularly important in rural areas.

CAUTION

Users should not attempt to make such connections themselves, but should contact the applicable electric inspection authority, or electrician.

The **Load Number (LN)** assigned to each terminal device denotes the percentage of the total load to be connected to a telephone loop which is used by the device to prevent overloading. The termination on a loop may consist of any combination of devices, subject only to the requirement that the total of load numbers of all devices does not exceed 100.

This equipment has been listed by the Canadian Standards Association and found to comply with all applicable requirements of the standard for telephone equipment C22.2 No. 225.

This equipment meets IC requirements CS03.

This digital apparatus does not exceed the Class A limits for radio noise emissions from digital apparatus as set out in the radio interference regulations of Industry Canada.

Le present appareil numerique n'emet pas de bruits radioelectriques depassant les limites applicables aux appareils numeriques de Classe A prescrites dans le reglement sur le brouillage radioelectrique edicte par Industrie Canada.

1.2.3 Battery Disposal

The Electra Professional Level I system includes the following batteries. When disposing of these batteries, KSUs and/or KTUs, you must comply with the rules and regulations of your state regarding proper disposal procedures.

<u>Unit Name</u>	<u>Type of Battery</u>	<u>Quantity</u>
ESF-C-10 KSU	Lead Acid	2
	Lithium	1
VRS-C(1)-11 KTU	NiCad	1
SMDR-C-10 KTU	NiCad	1

IMPORTANT SAFEGUARDS FOR BATTERY DISPOSAL

The product that you have purchased contains a rechargeable battery. The battery must be recycled or disposed of properly. At the end of its useful life, under various state and local laws, it may be illegal to dispose of this battery into the municipal waste stream. Check with your local solid waste officials for details in your area for recycling options or proper disposal.

Nickel-Cadium (or sealed lead) batteries must be returned to a federal or state approved Nickel-Cadium (or sealed lead) battery recycler. This may be where the batteries were originally sold or a local seller of automotive batteries. In Minnesota call 1-800-225-PRBA if further disposal information is required, or call 1-800-232-9632 for further information.

BATTERY AND PACKAGE LABELING

Ni-Cd

CONTAINS NICKEL-CADMIUM BATTERY. MUST BE RECYCLED OR DISPOSED OF PROPERLY. MUST NOT BE DISPOSED OF IN MUNICIPAL WASTE.



Pb

CONTAINS SEALED LEAD BATTERY. MUST BE RECYCLED OR DISPOSED OF PROPERLY. MUST NOT BE DISPOSED OF IN MUNICIPAL WASTE.

1.2.4 Incidence of Harm

If the system malfunctions, it may also cause harm to the telephone network. The telephone system should be disconnected until the source of the problem can be determined and until repair has been made. If this is not done, the telephone company may temporarily disconnect service.

1.2.5 Radio Frequency Interference

In compliance with FCC Part 15 rules, the following statement is provided:

IMPORTANT NOTE

"This equipment generates, uses, and can radiate radio frequency energy and if not installed and used in accordance with the Installation Service Manual, may cause interference to radio communications. This equipment has been tested and approved for compliance with the limits for a Class A computing device pursuant to Subpart J of Part 15 of FCC Rules, which are designed to provide reasonable protection against such interference when operated in a commercial environment. Operation of this telephone system in a residential area is likely to cause interference, in which case, the user, at his or her own expense, will be required to take whatever measures may be required to correct the interference."

1.2.6 Hearing Aid Compatibility

The NEC Multiline Terminals and Single Line Telephones provided for this system are hearing aid compatible. The manufacturers of other Single Line Telephones for use with the system must provide notice of hearing aid compatibility to comply with FCC rules. FCC rules prohibit the use of non-hearing aid compatible telephones (after August 16, 1989).

1.2.7 Service Requirements

In the event of equipment malfunction, all repairs should be performed by an authorized agent of NEC America, Inc. or by NEC America, Inc. Users requiring service are responsible for reporting the need for service to an authorized agent of NEC America, Inc. or to NEC America, Inc.

1.2.8 UL Regulatory Information

This equipment has been listed by Underwriters Laboratories and found to comply with all applicable requirements of the standard for telephone equipment UL 1459 2nd Edition.

1.3 List of Abbreviations

The following abbreviations are used throughout this chapter.

Table 1-1 List of Abbreviations

Abbreviation	Description
CO	Central Office
COI	Central Office Line Interface
CNF	Conference
CPU	Central Processing Unit
CTX	Centrex
ECR	External Control Relay
EPC	External Page Control
ESI	Electronic Station Interface
EXSP	External Speaker
FAX	Facsimile Transceiver
I/O	Input, Output
MLT	Multiline Terminal
MMC	Memory Module Control
PBR	DTMF Signal Receiver Circuit Unit (Push Button Receiver)
PFT	Power Failure Transfer
PRT	Printer with RS-232C Interface
PSU	Power Supply Unit
ROM	Read Only Memory
RAM	Random Access Memory
RTC	Real Time Clock
SLT	Single Line Telephone
SLT ADP	Single Line Telephone Adaptor
SMDR	Station Message Detail Recording
SPKR	Speaker
TDSW	Time Division Switch
TNG	Tone Generator
TP	Test Point
VMU	Voice Mail Unit
VRS	Voice Recording Service Unit

1.4 System Configuration Drawing

Figure 1-2 - System Configuration Drawing (Example) shows an example of a system with standard and optional (some locally provided) functions that are available with the Electra Professional Level I system.

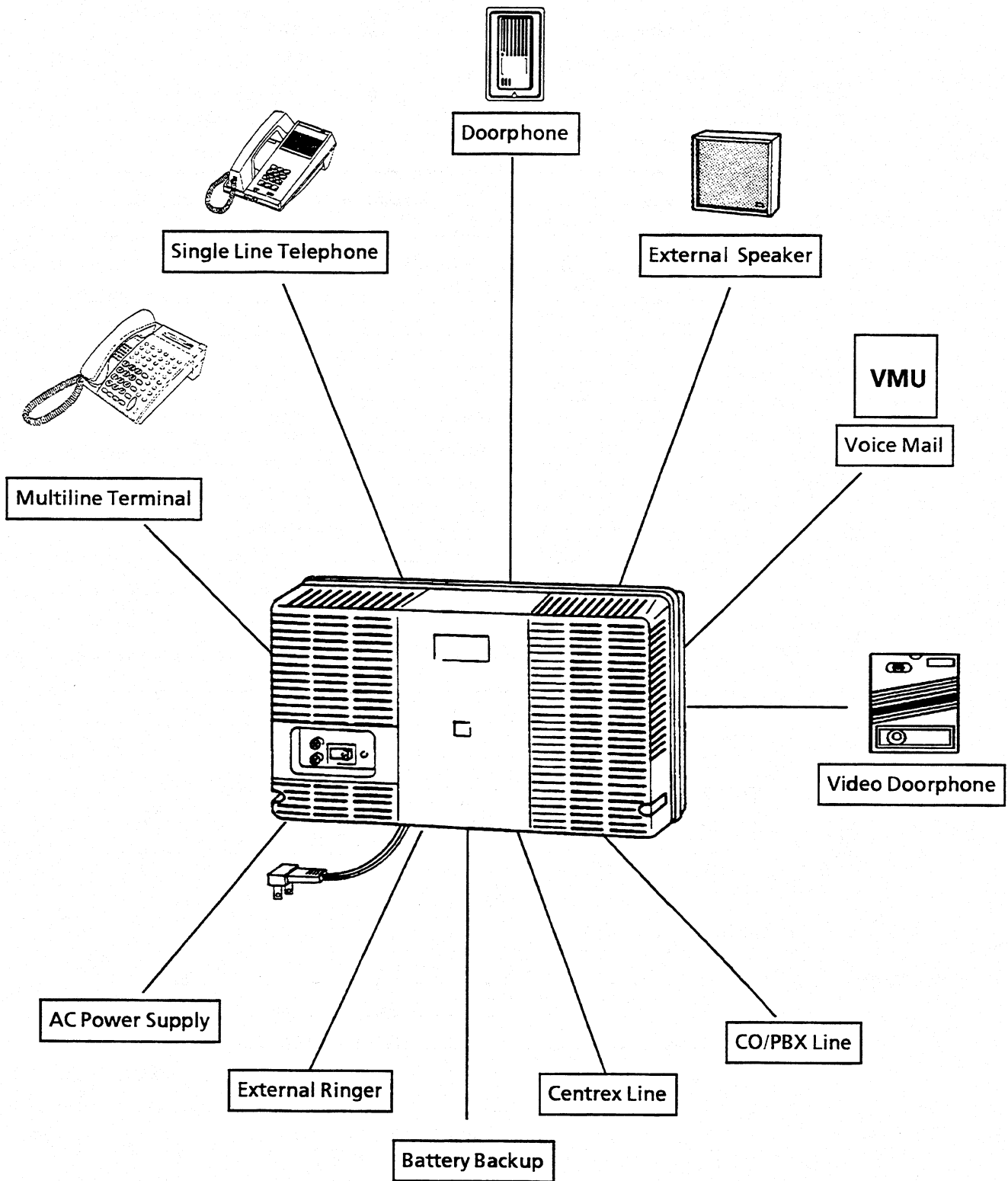

Figure 1-2 System Configuration Drawing (Example)

1.5 Equipment List

The following equipment is available for use in the system. The maximum quantities that can be installed in each system are listed in Tables 1-2 ~ 1-8.

Table 1-2 KSU and PSU

Equipment Designation	Maximum Quantity/System	Description
ESF-C-10 KSU	1	System KSU with PSF-C-10 PSU and batteries. Includes circuitry for: Tone Generator (TNG), Central Processing Unit (CPU), 4-channel Central Office Interface, 8-channel Station Interface, Conference, External Paging, Power Failure Transfer, two Doorphones, MOH/BGM, and four General Purpose Relays.
PSF-C-10 PSU	N/A	PSU (Spare Power Supply)
Battery	2	For system battery backup

Table 1-3 Station Interface KTU

Equipment Designation	Maximum Quantity/System	Description
ESI-C(8)-11 KTU	1	8-channel, 2-wire Electronic Station Interface

Table 1-4 Trunk Interface KTU

Equipment Designation	Maximum Quantity/System	Description
COI-C(2)-10 KTU	1	2-channel, Loop Start Central Office Interface
*COI-C(2A)-10 KTU	1	2-channel, Loop Start Central Office Interface

* Software version 3.0 or higher is required.

Table 1-5 Other Optional KTUs

Equipment Designation	Maximum Quantity/System	Description
PBR-C(4)-11 KTU	1	4-channel, DTMF/Push Button Receiver (PBR)
VRS-C(1)-11 KTU	1	1-channel, Voice Recording Service (VRS)
SMDR-C-10 KTU	1	Station Message Detail Recording
*FAX-C(1)-11 KTU	1	1-channel, Facsimile Connection

* Software version 2.0 or higher is required.

Table 1-6 Electra Professional Level I Terminals

Equipment Designation	Maximum Quantity/System	Description
DTU-8-() (BK) TEL DTU-8-() (WH) TEL	15	Black or white Electra Elite Digital Multiline Terminal with eight programmable line keys with two-color LED
DTU-16-() (BK) TEL DTU-16-() (WH) TEL	16	Electra Elite Digital Multiline Terminal with 16 programmable line keys with two-color LED
DTU-16D-() (BK) TEL DTU-16D-() (WH) TEL	16	Electra Elite Digital Multiline Terminal with display and 16 programmable line keys with two-color LED
DTU-32-() (BK) TEL DTU-32-() (WH) TEL	16	Electra Elite Digital Multiline Terminal with 32 programmable line keys with two-color LED
DTU-32D-() (BK) TEL DTU-32D-() (WH) TEL	16	Electra Elite Digital Multiline Terminal with display and 32 programmable line keys with two-color LED
ETW-8-1 (BK) TEL ETW-8-1 (SW) TEL	15	8-line non-display terminal with built-in speakerphone, ADA interface, large LED, and eight function keys
ETW-16DC-1 (BK) TEL ETW-16DC-1 (SW) TEL	16	16-line Display terminal with built-in speakerphone, ADA interface, large LED, eight function keys
ETW-16DD-1 (BK) TEL ETW-16DD-1 (SW) TEL	16	16-line Display terminal with built-in speakerphone, ADA interface, Large LED, eight function keys, and 20 programmable One-Touch keys with red LEDs,
ADA (1)-W (BK) Unit ADA (1)-W (SW) Unit	16	Black or soft white Ancillary Device Adaptor (for connection of headset, or recording interface)
ADA (2)-W (BK) Unit ADA (2)-W (SW) Unit	16	Ancillary Device Adaptor (for connection of cordless telephone, Single Line Telephone, facsimile, modem, or answering machine)
WMU-U (BK)/(SW) WMU-W(BK)/(SW)	16	Wall Mount Unit (WMU-U for Electra Elite; WMU-W for Electra Professional)

Table 1-7 Single Line Telephone Adaptor

Equipment Designation	Maximum Quantity/System	Description
SLT-F(1G)-10 ADP	4	Single Line Telephone Adaptor
SLT-F(1G)-20 ADP	4	Single Line Telephone Adaptor (with loop open disc)

Table 1-8 Doorphone Equipment

Equipment Designation	Maximum Quantity/System	Description
DP-D-1A Unit	2	Doorphone Unit

1.6 Equipment General Information

One *Electra Professional Level I Job Specifications Manual* (Stock No. 722004) is included with each ESF-C-10 KSU. All optional equipment (e.g., external amplifiers, Music On Hold source, Background Music source, or external speakers) must be locally provided.

1.7 Equipment Description

1.7.1 Key Service Units and Power Supply Units

ESF-C-10 KSU

The Key Service Unit (KSU) provides service for outside CO/PBX, internal lines, and connection of Multiline Terminals. The basic KSU provides for the connection of four CO/PBX lines and eight stations and can be expanded to eight CO/PBX lines and 16 stations with expansion modules. A PSF-C-10 PSU Power Supply Unit and internal batteries are included with the KSU.

Fixed slots are intended for COI-C(2)-10, COI-C(2A)-10, ESI-C(8)-11, PBR-C(4)-11, VRS-C(1)-11, FAX-C(1)-11, and SMDR-C-10 KTUs.

PSF-C-10 PSU

The Power Supply Unit is provided with the KSU. It has a battery interface cable for battery backup, accepts 117 Vac, and outputs +5Vdc and +28Vdc to the system.

1.7.2 Station Interface Key Telephone Unit

ESI-C(8)-11 KTU

The Electronic Station Interface KTU contains eight circuits, and each can support three types of Multiline Terminals or an SLT Adaptor.

One ESI-C(8)-11 KTU can be installed in the KSU.

1.7.3 Trunk Interface Key Telephone Unit

COI-C(2)-10 KTU

The Central Office Interface KTU complies with UL 1459 2nd Edition requirements. Electrical fuses (posistors) are built into this KTU. The COI-C(2)-10 KTU supports two outside (CO/PBX) lines and provides circuitry for ring detection, holding, and dialing. The outside lines can be any combination of loop start, DTMF, or Dial Pulse dialing trunks.

One COI-C(2)-10 KTU can be installed in the KSU.

COI-C(2A)-10 KTU

The Central Office Interface KTU complies with UL 1459 2nd Edition requirements. Electrical fuses (posistors) are built into this KTU. The COI-C(2A)-10 KTU supports two outside (CO/PBX) lines and provides circuitry for ring detection, holding, and dialing. The outside lines can be any combination of loop start, DTMF, or Dial Pulse dialing trunks. (Software version 3.0 or higher is required.)

One COI-C(2A)-10 KTU can be installed in the KSU.

1.7.4 Optional Key Telephone Units

PBR-C(4)-11 KTU

The Push Button Receiver (PBR) 4-Channel KTU detects and translates DTMF tones received by the Automated Attendant and generated by Single Line Telephones, modems, or facsimile machines.

The interface slots can accommodate one PBR-C(4)-11 KTU for a maximum of four circuits per system.

VRS-C(1)-11 KTU

The Voice Recording Service KTU provides voice recording messages for Automated Attendant, internal stations, manual messages, hold messages and automatic/manual answering of incoming CO/PBX calls by a voice recorded message. (Software version 2.0 or higher is required.)

One VRS-C(1)-11 KTU can be installed in the KSU.

SMDR-C-10 KTU

The Station Message Detail Recording KTU stores and generates detailed call records for all outgoing CO/PBX calls.

Information provided by SMDR-C-10 KTU includes:

- Calling party's station number
- CO/PBX line used for the call
- Start time of call
- End time of call
- Number dialed
- Date of call

One SMDR-C-10 KTU can be installed in the KSU. The SMDR-C-10 KTU mounts onto the main printed circuit board of the system.

A serial printer or other peripheral recording device must be locally supplied and terminated to the RS-232C connector from the SMDR-C-10 KTU.

FAX-C(1)-11 KTU

The Fax KTU provides for the direct connection of a locally provided facsimile machine. Additional dedicated CO/PBX lines are not required for the facsimile to operate. The facsimile shares usage of the fourth CO/PBX terminated line (version 2.0 software or higher is required).

One FAX-C(1)-11 KTU can be installed in the KSU.

1.7.5 **Electra Elite Digital Multiline Terminals, Electra Professional Multiline Terminals, Single Line Telephones, and Associated Equipment**

DTU-8-() (BK)/(WH) TEL

This non-display Digital Multiline Terminal has eight programmable Line keys (each with a two-color LED), built-in speakerphone, headset jack, a large LED to indicate incoming calls and messages, and compatibility with ADA-U, APR-U, and HFU-U Units. This terminal comes in black or white.

A maximum of 15 DTU-8-1 (BK)/(SW) TELs can be installed in a system.

DTU-16-() (BK)/(WH) TEL

This non-display Digital Multiline Terminal has 16 programmable Line keys (each with a two-color LED), built-in speakerphone, a large LED to indicate incoming calls and messages, and compatibility with ADA-U, APR-U, and HFU-U Units. This terminal comes in black or white.

A maximum of 16 DTU-16-() (BK)/(SW) TELs can be installed in a system.

DTU-16D-(1) (BK)/(WH) TEL

This display Digital Multiline Terminal has 16 programmable Line keys (each with a two-color LED), built-in speakerphone, a large LED to indicate incoming calls and messages, and compatibility with ADA-U, APR-U, and HFU-U Units. This terminal comes in black or white.

The adjustable LCD has 3,24-character lines

A maximum of 16 DTU-16D-() (BK)/(SW) TELs can be installed in a system.

DTU-32-() (BK)/(WH) TEL

This non-display Digital Multiline Terminal has 32 programmable Line keys (each with a two-color LED), built-in speakerphone, a large LED to indicate incoming calls and messages, four Soft keys, and compatibility with ADA-U, APR-U, and HFU-U Units. This terminal comes in black or white.

A maximum of 16 DTU-32-() (BK)/(SW) TELs can be installed in a system.

DTU-32D-(1) (BK)/(WH) TEL

This display Digital Multiline Terminal has 32 programmable Line keys (each with a two-color LED), built-in speakerphone, a large LED to indicate incoming calls and messages, and compatibility with ADA-U, APR-U, and HFU-U Units. This terminal comes in black or white.

The adjustable LCD has 3,24-character lines

A maximum of 16 DTU-16D-() (BK)/(SW) TELs can be installed in a system.

ETW-8-1 (BK)/(SW) TEL

This Multiline Terminal is a fully modular instrument with eight Flexible Line keys (each with a two-color LED), eight function keys, built-in speakerphone, ADA interface, and a large LED to indicate incoming calls and messages. This Multiline Terminal is available in two colors: black (BK) or soft-white (SW).

A maximum of 15 ETW-8-1 (BK)/(SW) TELs can be installed in a system.

ETW-16DC-1 (BK)/(SW) TEL

This Multiline Terminal is a fully modular instrument with 16 Flexible Line keys (each with a two-color LED), eight function keys, built-in speakerphone, a 16-character Liquid Crystal Display (LCD), ADA compatibility and a large LED to indicate incoming calls and messages. This Multiline Terminal is available in two colors: black (BK) or soft-white (SW).

A maximum of 16 ETW-16DC-1 (BK)/(SW) TELs can be installed in a system.

ETW-16DD-1 (BK)/(SW) TEL

This Multiline Terminal is a fully modular instrument with 16 Flexible Line keys (each with a two-color LED), eight function keys, built-in speakerphone, 20 programmable One-Touch keys with LEDs, ADA compatibility, and a large LED to indicate incoming calls and messages. This Multiline Terminal is available in two colors: black (BK) or soft-white (SW).

A maximum of 16 ETW-16DD-1 (BK)/(SW) TELs can be installed in a system.

ETJ-1-1 (SW) TEL

This Single Line Telephone is a fully modularized terminal with a Flash key, Redial key, three-level ring volume control, data jack, and message waiting lamp. Each terminal requires one port of an SLI-F(8G)-21 KTU, LLT-F(2G)-10 KTU, SLT-F(1G)-20 ADP, or SLT-F(1G)-10 ADP.

ETJ-1HM-1 (SW) TEL

This Single Line Telephone is a fully modularized terminal with a Flash key, Redial key, three-level ring volume control, data jack, message waiting lamp, and eight programmable Feature/Speed Dial keys. Each terminal requires one port of an SLI-F(8G)-21 KTU, LLT-F(2G)-10 KTU, SLT-F(1G)-20 ADP, or SLT-F(1G)-10 ADP.

ADA(1)-W (BK)/(SW) Unit

The Ancillary Device Adaptor provides the Multiline Terminal with connection for a headset, external speakerphone, or other ancillary devices. This unit can be installed in any Multiline Terminal and is available in two colors: black (BK) or soft-white (SW).

A maximum of 16 ADA(1)-W (BK)/(SW) Units can be installed in a system, one per Multiline Terminal.

ADA(2)-W (BK)/(SW) Unit

The ADA(2)-W (BK)/(SW) Unit (Ancillary Device Adaptor) provides the Multiline Terminal with connection for single line equipment such as a cordless telephone, Single Line Telephone, modem, facsimile machine, or answering machine. An ADA(2)-W (BK)/(SW) Unit can be installed in any Multiline Terminal and comes in black or soft-white.

A maximum of 16 ADA(2)-W (BK)/(SW) Units can be installed in a system, one per Multiline Terminal.

WMU-U (BK)/(SW) Unit

This Wall Mount Unit accommodates adapters that are installed in the Electra Elite Digital Multiline Terminal which can be used to mount any Multiline Terminal on a wall. This unit comes in two colors: black (BK) or soft-white (SW).

WMU-W (BK)/(SW) Unit

The WMU-W is a universal Wall Mount Unit, which can be used to mount any Multiline Terminal on a wall. This unit is available in black or soft-white.

1.7.6 Single Line Telephone Adaptors**SLT-F(1G)-10 ADP**

This Single Line Telephone Adaptor provides an interface for a Single Line Telephone, voice mail, or similar devices from an ESI-C(8)-11 KTU channel. A maximum of four SLT-F(1G)-() ADPs can be installed.

SLT-F(1G)-20 ADP

This Single Line Telephone Adaptor provides an interface for a Single Line Telephone, voice mail, or similar devices from an ESI-C(8)-11 KTU channel. A loop open disconnect can be provided. A maximum of four SLT-F(1G)-() ADPs can be installed. (Software version 2.72 or higher is required.)

1.7.7 Doorphone Equipment**DP-D-1A Unit**

The doorphone originates a tone signal to preassigned Multiline Terminals via a call button. This unit is generally installed at front and rear doors of secured work areas and can also be used as a 1-way room monitor to listen to an area.

A maximum of two weather-resistant DP-D-1A Units can be installed in a system.

SECTION 2 SYSTEM SPECIFICATIONS**2.1 General Information**

The following diagrams and tables show specifications for the system. The technician should review these carefully before attempting to install the system.

2.2 System Block Diagram

The system block diagram shows a conceptual representation of an installed system. (Refer to Figure 1-3 - System Block Diagram. Refer also to Table 1-1 - List of Abbreviations.)

Electra Professional Level I

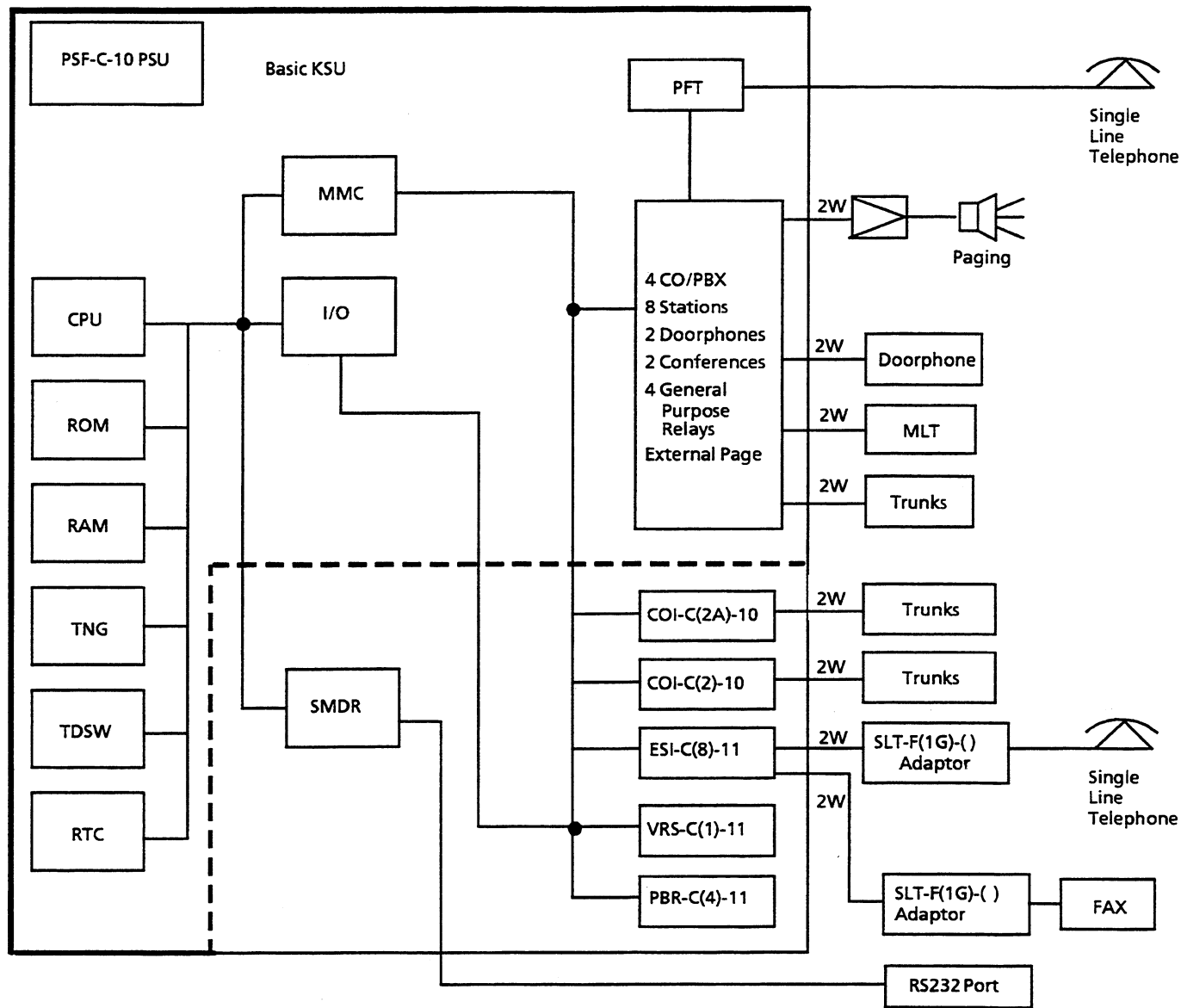

Figure 1-3 System Block Diagram

2.3 System Control Capacities

The control capacities of the system are shown in Table 1-9 - System Control Capacities.

Table 1-9 System Control Capacities

Item	KSU	Basic + Optional KTUs	Unit	No. of Circuits or No. of Telephones to be Connected/Unit
Number of CO/PBX Line	4	8	KSU COI	*4/4
Number of Internal Lines	Non-Blocking		KSU	N/A
Maximum Number of Stations	8	16	KSU/ ESI	*8/8
External Speaker	1	1	KSU	1
DTMF Signal Receiver Circuit	0	4	PBR	4
Voice Recording Services	0	1	VRS	1
SMDR	0	1	SMDR	1
Conference Trunk (4-party)	2	2	KSU	2
Tenant	4	4	KSU	N/A
Trunk Groups	3	3	KSU	N/A
System Speed Dial	80	80	KSU	N/A

* Denotes number of circuits in the KSU/Optional KTUs.

2.4 Cabling Requirements

2.4.1 Cabling Specifications

The KSU is connected with each of the Multiline Terminals and Single Line Telephones by a separate twisted 1-pair or 2-pair cable (only for Multiline Terminals). Table 1-10 - Multiline Terminal Loop Resistance and Cable Length and Table 1-11 - Single Line Telephone Connection Cable Length show the cables used for wiring between the KSU and individual terminals or adaptors.

Table 1-10 Multiline Terminal Loop Resistance and Cable Length

Terminal or Adaptor	Maximum Loop Resistance	Maximum Feet by Twisted 1-Pair Cable	Maximum Feet by Twisted 2-Pair Cable
		24AWG	24AWG
DTU-8-() (BK)/(WH)TEL	35	600	1000
DTU-16-() (BK)/(WH)TEL	26	450	900
DTU-16D-() (BK)/(WH)TEL	26	450	900
DTU-32-() (BK)/(WH)TEL	21	360	720
DTU-32D-() (BK)/(WH)TEL	21	360	720
ETW-8-1 (BK)/(SW) TEL	61	600	1500
ETW-16DC-1 (BK)/(SW) TEL	46	450	1300
ETW-16DD-1 (BK)/(SW) TEL	37	360	820
SLT-F(1G)-10 ADP/SLT-F(1G)-20 ADP	61	600	1200
DP-D-1A Unit	20	410	820

Note 1: The length for the specified SLT Adaptor is measured between the ESI KTU and the SLT Adaptor.

Note 2: When additional length is required between the ESI and the Multiline Terminal or the SLT Adaptor, use twisted 2-pair cable as shown in Figure 1-4 - Connecting the ESI to the Multiline Terminal Using Twisted 2-Pair Cable.

Table 1-11 Single Line Telephone Connection Cable Length

Connected Equipment	Cable	Maximum Feet or Loop Resistance (24 AWG)
SLT-F(1G)-() ADP	Twisted 1-pair	500 Ω

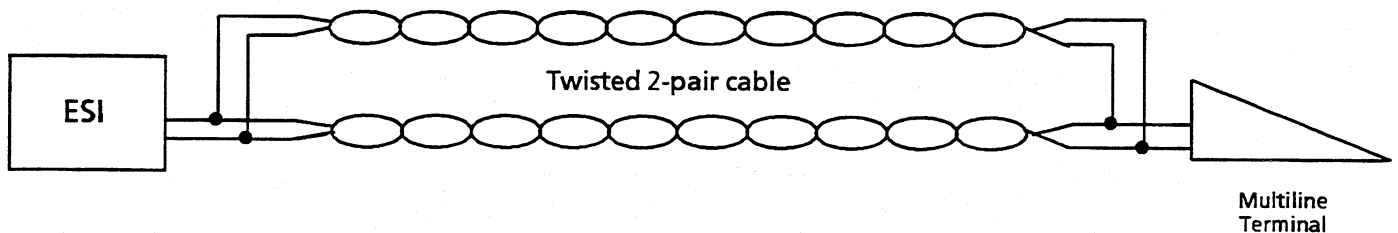

Figure 1-4 Connecting the ESI to the Multiline Terminal Using Twisted 2-Pair Cable

2.4.2 Cabling Precautions

When selecting cables and Main Distribution Frames (MDF), future expansion or assignment changes should be given due consideration. Avoid running cables in the following places:

- A place exposed to wind or rain.
- A place near heat radiating equipment or where the quality of station cable covering could be affected by gases and chemicals.
- An unstable place subject to vibration.

2.5 Power Requirements

2.5.1 Power Supply Inputs

AC Input (PSF-C-10 PSU)

- 120 Vac \pm 10%
- 60 Hz \pm 10%
- Single Phase
- Maximum Current: 2.3A
- A dedicated outlet, separately fused and grounded, is required.

2.5.2 Power Supply Outputs

Table 1-12 Power Outputs

DC Voltage	Minimum Current*	Maximum Current**
+28V	0.01A	2.3A
+5V	0.3A	3.0A

* Basic KSU Only

** Fully Loaded

Multiline Terminal

- Voltage: +11 Vdc ~ +28 Vdc
- Maximum Current: 200 mA

Acoustical characteristics meet Electronic Industry Association (EIA) standard proposal SP-1286 and standard EIA RS-470.

Single Line Telephone Adaptor [SLT-F(1G)-() ADP]:

- Standard 2500 Set: 500 type network
- Nominal Current: 30 mA
- Ring Signal: 56 Vac RMS @ 20 Hz

2.5.3 Power Consumption and Dissipation

Basic KSU

- Maximum RMS Current: 0.6A
- Watts Used (Idle): 20W
- Watts Used (Maximum): 52W

Fully Loaded KSU

- Maximum RMS Current: 2.3A
- Watts Used (Idle): 40W
- Watts Used (Maximum): 105W

2.5.4 Fuse Replacement

Table 1-13 Fuse Replacement

Unit	Fuse No.	Specifications	Description	Dimensions
PSF-S-20 PSU	F0	250V, 6.3A	AC Input	1/4" X 1-1/4"
	F1	250V, 6.3A	DC Input	1/4" X 1-1/4"
	F2	125V, 2A	+5V Input and +28V	1/4" X 1-1/4"
	F3	125V, 5A	Battery Input	1/4" X 1-1/4"

Note: F0 and F1 fuses are normal blown glass tube. Do not use slow blow fuses.

2.6 Environmental Conditions

Temperature

- Operating: 50° F ~ 104° F (10° C ~ 40° C)
- Recommended Long Term: 50° F ~ 90° F (10° C ~ 32.2° C)

Operating Humidity: 10% ~ 90% noncondensing

2.7 Outside Line Types

- 2-wire, Loop Start Trunks

2.8 Network and Control Specifications

2.8.1 Transmission

- Data Length:
 - From Multiline Terminal to Electronic Station Port: 23 bits
 - From Electronic Station Port to Multiline Terminal: 23 bits
- Data Transmission Rates:
 - Between Electronic Station Port and Multiline Terminal: 512 Kbits/sec.
- Scanning Time for Each Multiline Terminal: 64 ms.

2.8.2 Network

- TDM Switching: PCM (μ Law)
- TDM Clock: 2.048 MHz
- TDM Slot Period: 125 μ s./32
- TDM Data Bus: 8 bits
- TDM Timeframe: 125 μ s.

2.8.3 Control

- Control: Stored program with distributed processing
- Central Processor: 8-bit microprocessor
- Clock: 8 MHz
- Multiline Terminal: 4-bit, 1 chip microprocessor
- SLT Adaptor: 4-bit, 1 chip microprocessor

2.9 Dialing Specifications

2.9.1 Dial Pulse Address Signaling

- Pulse Rate: 10 ± 0.8 pps/ 20 ± 1.6 pps
- Make Ratio: $39 \pm 3\%$
- Interdigit Interval: 800 ms.
- Minimum Pause: 600 ms. (10 pps)
450 ms. (20 pps)

2.9.2 DTMF Address Signaling

- Frequencies: Low Group: 697 Hz, 770 Hz
852 Hz, 941 Hz
High Group: 1209 Hz, 1336 Hz
1477 Hz
- Frequency Deviation: $\pm 1.5\%$ maximum
- Nominal Level per Frequency: -6 dBm ~ -4 dBm
- Minimum Level per Frequency: Low Group: -10 dBm
High Group: -8 dBm
- Rise Time: Within 5 ms.
- Duration: 70 ms. (default), 70 ms. (min.), 900 ms. (max.)
Interdigit: 60 ms. (default), 60 ms. (min.), 200 ms. (max.)

	Nominal High Group		
	1209	1336	1477
697	1	2	3
770	4	5	6
852	7	8	9
941	*	0	#

Nominal Low Group Frequencies (Hz)

2.10 Battery Backup

The system has two battery backup functions: one for system backup and a second for memory backup.

2.10.1 System Backup

The system is backed up by a rechargeable battery. This battery should backup all of the system functions for approximately 10 minutes if power fails.

2.10.2 Memory Backup

The backup battery is equipped on the basic KSU [VRS-C(1)-11 KTU] and the SMDR-C-10 KTU. These NiCad batteries, when fully charged, retain the system memory if power fails. (Refer to Table 1-14 - KTU Battery Backup Time for the approximate back up time for the KTUs.)

Table 1-14 KTU Battery Backup Time

KTUs	Approximate Backup Time
Basic KSU	18 months
VRS-C(1)-11 KTU	2 hours
SMDR-C-10 KTU	1 month

The functions that are supported by the backup batteries are:

- Background Music
- Call Forwarding
- Clock/Calendar
- Do Not Disturb
- Last CO/PBX Redial
- Message Waiting
- Microphone Status
- Night Transfer Status
- Room Monitor
- Save and Repeat
- SMDR Data
- Speed Dial Memories (System and Station)
- Store and Repeat
- System Program
- Timed Alarm
- Volume Control/LCD Contrast
- VRS Data

2.10.3 Battery Backup - Full System Power

Two locally provided 12 Vdc, sealed lead acid storage batteries (PE0.7-12R or equivalent) are recommended.

- Weight: 0.77 lbs. (35 g.)
- Contact Type: W2
- Size:
 - Length: 3.78 in. (96 mm)
 - Width: 0.98 in. (25 mm)
 - Height: 2.42 in. (6.15 mm)
 - Depth: 2.42 in. (6.15 mm)
- Maximum Discharge Current: 2.1A
- Temperature:
 - Operating: 32° F ~ 104° F (0° C ~ 40° C)
 - Storage: -40° F ~ 104° F (-20° C ~ 40° C)

CAUTION

Do not short-circuit the batteries. The battery could explode and cause damage to personnel and equipment.

2.11 Weights and Dimensions

Table 1-15 Weights and Dimensions

Unit	Shipping Weight *	Height	Width	Depth
ESF-H-10 KSU	37 lbs. 6 oz. (17 kg)	14.4 inches (360 mm)	15.92 inches (398 mm)	9.2 inches (230 mm)
PSF-H-20 PSU	4 lbs. 13 oz. (2.2 kg)	14.96 inches (380 mm)	3.54 inches (90 mm)	7.09 inches (180 mm)
DTU-8-() (BK)/(WH) TEL	2 lbs. (0.9 kg)	4.4 inches (109.9 mm)	7 inches (177 mm)	8.8 inches (223.7 mm)
DTU-16-() (BK)/(WH) TEL	2 lbs. 3 oz. (1 kg)	4.4 inches (109.9 mm)	7.9 inches (210 mm)	8.8 inches (223.7 mm)
DTU-16D-() (BK)/(WH) TEL	2 lbs. 4 oz. (1 kg)	4.4 inches (109.9 mm)	7 inches (177 mm)	9.1 inches (229 mm)
DTU-32-() (BK)/(WH) TEL	2 lbs. 7 oz. (1.1 kg)	4.4 inches (109.9 mm)	7 inches (177 mm)	8.8 inches (223.7 mm)
DTU-32D-() (BK)/(WH) TEL	2 lbs. 7 oz. (1.1 kg)	4.4 inches (109.9 mm)	7.9 inches (210 mm)	9.1 inches (229 mm)
ESF-C-10 KSU	Approximately 9 lbs.	13 inches (325 mm)	19 inches (475 mm)	4.16 inches (104 mm)
ETW-8-1 (BK)/(SW) TEL	2 lbs. (0.9 kg)	3.98 inches (101 mm)	6.89 inches (175 mm)	8.81 inches (223 mm)
ETW-16DC-1 (BK)/(SW) TEL	2 lbs. 3 oz. (1 kg)	3.98 inches (101 mm)	6.89 inches (175 mm)	8.81 inches (223 mm)
ETW-16DD-1 (BK)/(SW) TEL	2 lbs. 7 oz. (1.1 kg)	3.98 inches (101 mm)	8.07 inches (205 mm)	8.81 inches (223 mm)
ETJ-1-1 (SW) TEL	2 lbs. (0.9 kg)	3.98 inches (101 mm)	6.89 inches (175 mm)	8.81 inches (223 mm)
ETJ-1HM-1(SW) TEL	2 lbs. 3 oz. (1 kg)	3.98 inches (101 mm)	6.89 inches (175 mm)	8.81 inches (223 mm)
ETE-1-2 TEL	1 lb. 14 oz. (0.10 kg)	3.15 inches (80 mm)	6.30 inches (160 mm)	9.06 inches (230 mm)
ETE-1HM-2J TEL	1 lb. 10 oz. (0.7 kg)	2.36 inches (60 mm)	6.30 inches (160 mm)	9.06 inches (230 mm)

* Shipping weight includes the shipping carton.

2.12 External Equipment Interface**2.12.1 Music On Hold (MOH)/Background Music (BGM)**

- Connector: 4-position, quick connector
- Auxiliary Input: 1.0V RMS Signal Level max./min.
- Input Impedance: 600 Ω

2.12.2 Station Message Detail Recording (SMDR)

- Female connector (system output) standard RS-232C (serial output)

2.12.3 External Paging

- Output Level: -15.0 dBm Signal Level, +4 dBm max.
- Output Impedance: 600 Ω







2.12.4 General Purpose Relays

- Contact Rating: 1 A @ 24 Vdc
150 mA @ 48Vdc

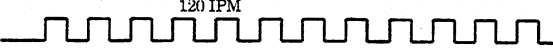
2.13 Visual and Audible Indications

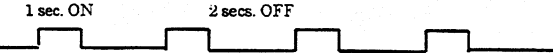
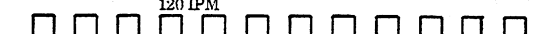
2.13.1 Tone Patterns Table

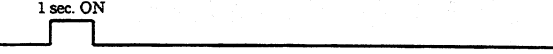
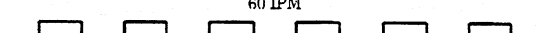
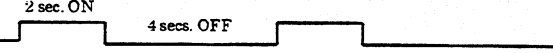
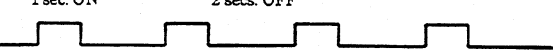
Table 1-16 Tone Patterns

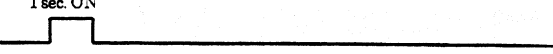
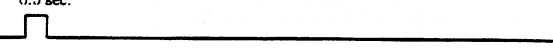
Tone	Frequency (Hz)	Tone Patterns
Dial Tone	350/440	
Second Dial Tone	350/440	 120 IPM
Busy Tone	480/620	 60 IPM
Call Waiting Tone	440	 60 IPM
Ringback Tone	440/480	 1 sec. ON 2 secs. OFF
Reorder Tone	480/620	 120 IPM
Tone Override Camp-On Tone	440	 0.5 sec.
Confirmation Tone	440	 1 sec. ON
Recall Tone	1024	 60 IPM
CO/PBX Ring Tone	600/700 or 1024/1285	 2 sec. ON 4 secs. OFF
ICM Ring Tone	500	 1 sec. ON 2 secs. OFF
Voice Page Alert Tone (Tone Burst)	440	 0.5 sec.
Howler Tone	2400	 16 Hz Modulation
Barge-In Tone	440	 1 sec. ON
Voice Over Tone	440	 0.5 sec.

2.13.2 Multiline Terminal Flash Patterns Table

Table 1-17 Multiline Terminal LED Flash Patterns

LED	Condition	Color	Flash Patterns				
Line Key	I-Use	Green	[Solid line]				
	Busy	Red	[Solid line]				
	Incoming Call	Red	[Dashed line]				
	I-Hold	Green	[Dashed line]				
	Call Hold	Red	[Dashed line]				
	Hold Recall	Green	[Dashed line]				
	Transfer Recall	Green	[Dashed line]				
Microphone	ON	Red	[Solid line]				
	Monitored	Red	[Dashed line]				
ICM	I-Use	Red	[Solid line]				
	ICM Incoming Call	Red	[Dashed line]				
Large LED	Incoming Internal Call	Red	[Dashed line]				
	Incoming CO Line	Green	[Dashed line]				
	Voice Mail Message	Red	[Dashed line]				
	VRS Message	Red	[Dashed line]				
Speaker	ON	Red	[Solid line]				
	System Data Entry	Red	[Dashed line]				
	Monitor	Red	[Dashed line]				
Conference	Conference in Progress	Red	[Solid line]				
	All Conference	Red	[Solid line]				
	Circuits Used	Red	[Solid line]				
	Hold Conference Call	Red	[Dashed line]				
	ICM Call Hold	Red	[Dashed line]				
	SPD Confirmation	Red	[Dashed line]				
Answer	Incoming Trunk	Red	[Dashed line]				
	Voice Over Split	Green	[Dashed line]				
	Preset	Red	[Dashed line]				
Function	Callback Set	Red	[Dashed line]				
	DND, Call FWD	Red	[Dashed line]				
	Auto Redial Set	Red	[Dashed line]				
	ON (to Set Function)	Red	[Dashed line]				
LNR/SPD	CO Line Key Seized	Green	[Dashed line]				
	Exclusive Hold	Green	[Dashed line]				
BLF or DSS Key	Use, Hold, ICM Called	Red	[Dashed line]				
	DND, Call FWD All	Red	[Dashed line]				
	Set Special Mode (While pressing FNC key or going off-line)	Red	[Dashed line]				

0 0.5 1.0 1.5 2.0 sec.

2.13.3 DSS/BLF LED Indications Table

Table 1-18 DSS/BLF LED Indications

Function	Color	Status
Idle		OFF
Talking	Red	ON
Hold	Red	ON
FWD All and DND	Red (Flashing)	ON
Other Use (Multiline Terminal is in off-line mode, the station user is programming, Feature Access/One-Touch Key programming, etc.)	Red (Flashing)	ON

SECTION 3 HARDWARE REQUIREMENTS

3.1 General Information

Before configuring the system, complete the worksheets provided in the *Electra Professional Level I Job Specifications Manual* (Stock No. 722004). Make sure all types of station equipment, timeouts, and feature options are considered when completing the worksheets. It is necessary to understand System Programming to properly complete these worksheets. (Refer to Chapter 2 - Programming in this manual.)

Note: One *Electra Professional Level I Job Specifications Manual* is included with each ESF-C-10 KSU.

The KSU has five fixed slots, one for each optional/interface KTU.

When possible, the same type KTUs should be paired together within a cable binder (25-pair cable binders to the MDF should be used). This will simplify MDF wiring.

3.1.1 Programming Stations

A maximum of two programming positions are available in the system. The first two ports of the KSU are automatically set as programming positions, and programming station equipment must be an ETW-16DC-1 (BK)/(SW) TEL, ETW-16DD-1 (BK)/(SW) TEL, DTU-16D-() (BK)/(WH) TEL, or DTU-32D-() (BK)/(WH) TEL.

The first two programming positions are system Attendants and are fixed in system software.

3.1.2 Attendant Stations

A maximum of two Attendant Positions can be installed in a system.

3.2 Determining Required Equipment

3.2.1 Station Equipment

Determine the type and quantity of station equipment being installed. The type of station equipment available includes:

- DTU-8-() (BK)/(WH) TEL (8-line Multiline Terminal without LCD)
- DTU-16-() (BK)/(WH) TEL (16-line Multiline Terminal without LCD)
- DTU-16D-() (BK)/(WH) TEL (16-line Multiline Terminal with LCD)
- DTU-32-() (BK)/(WH) TEL (8-line Multiline Terminal without LCD)
- DTU-32D-() (BK)/(WH) TEL (16-line Multiline Terminal with LCD)
- ETW-8-1 (BK)/(SW) TEL (8-line Multiline Terminal without LCD)
- ETW-16DC-1 (BK)/(SW) TEL (16-line Multiline Terminal with LCD)
- ETW-16DD-1 (BK)/(SW) TEL (16-line Multiline Terminal with LCD)
- Single Line Telephone with Message Wait Lamp
- Single Line Telephone without Message Wait Lamp
- SLT-F(1G)-() ADP
- Doorphones (Doorphone or video doorphones with monitoring station)

3.2.2 Interface KTUs

Interface KTUs can be added to expand the system to full capacity. (Refer to Figure 1-5 - Full Capacity KSU and Table 1-19 - Number of Required Interface KTUs.)

- ESI-C(8)-11 KTU: 8 stations
- COI-C(2)-10 KTU: 2 CO lines
- COI-C(2A)-10 KTU: 2 CO lines

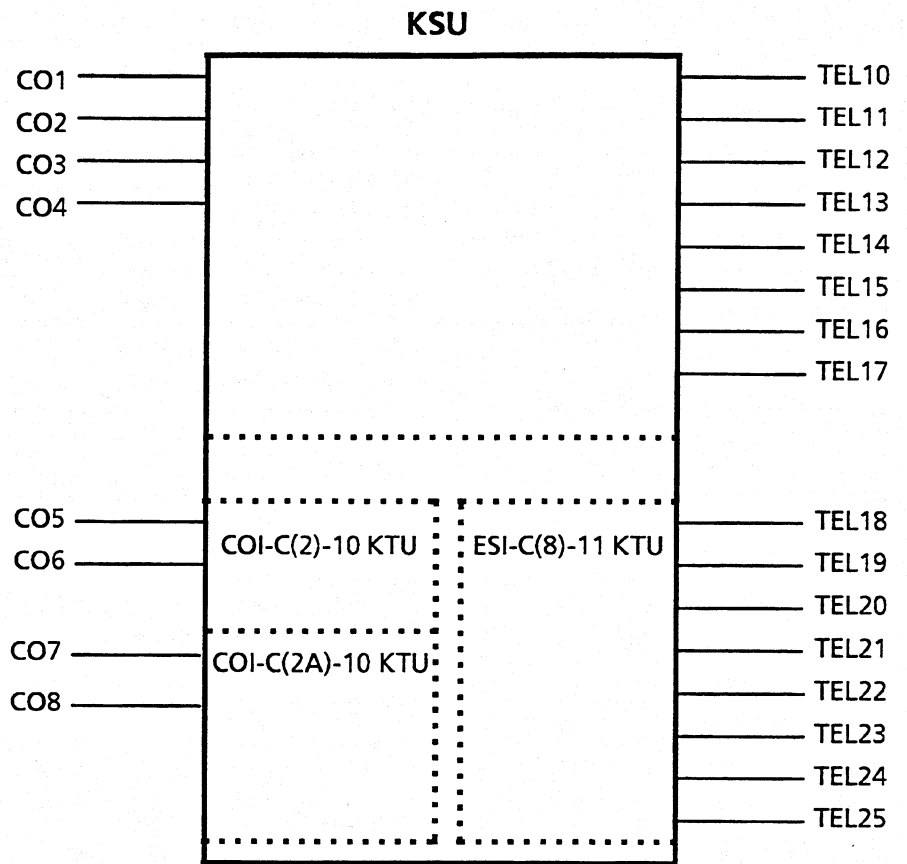

Figure 1-5 Full Capacity KSU

Table 1-19 Number of Required Interface KTUs

KTU	Circuits per KTU	Calculations/Comments	Maximum KTUs per System
COI-C(2)-10 KTU	2	Required if the number of CO/PBX/Centrex lines being used is 5 or 6.	1
COI-C(2A)-10 KTU	2	Required if the number of CO/PBX/Centrex lines being used is 7 or 8.	1
ESI-C(8)-11 KTU	8	Required if the number of Multiline Terminals and SLT Adaptors being used is greater than 8.	1
PBR-C(4)-11 KTU	4	PBR Requirements (Refer to section 3.2.3 - PBR Requirements.)	1
VRS-C(1)-11 KTU	1	Required for Automated Attendant, VRS-Auto/Manual Answer, and VRS-Internal.	1
SMDR-C-10 KTU	1	Required for Station Message Detailed Recording.	1
FAX-C(1)-11 KTU	1	Required for facsimile connection.	1

3.2.3 PBR Requirements

The Electra Professional Level I system has four channels of PBR circuits on the PBR-C(4)-11 KTU. The PBR circuit can detect DTMF signals from a Single Line Telephone, facsimile, modem, voice mail, or ADA(2).

3.3 Installation Example

The following example aids in understanding some of the requirements when configuring an Electra Professional Level I system. (Refer to Table 1-20 - System Configuration Example.) The equipment used in this example includes:

- 5 CO Lines
- 9 Multiline Terminals [ETW-16DD-1 (BK)/(SW) TEL only]
- Voice Mail Connection (2 ports)
- SMDR
- External Paging

Table 1-20 System Configuration Example

Device Type	Units	Quantity
Key Service Unit	ESF-C-10-KSU	1
CO Line	COI-C(2)-10 KTU or COI-C(2A)-10 KTU	1
Multiline Terminal Interface	ESI-C(8)-11 KTU	1
Multiline Terminal	ETW-16DD-1 (BK)/(SW) TEL	9
Voice Mail Connection (2 ports)	SLT-F (1G)-() ADP	2
SMDR	SMDR-C-10 KTU	1
External Paging	N/A	N/A

SECTION 4 KSU INSTALLATION

4.1 General Information

This section provides the requirements for installing the system. The installer should be familiar with this section before installing the system.

4.2 Site Preparation and MDF/IDF Construction

The technician should plan the installation before actual work begins. Advanced planning minimizes time, cost, and disruption of the customer's business activities. Additional benefits include flexibility for changes and expansion, efficient maintenance, and increased customer satisfaction.

4.2.1 Precautionary Information

The following warnings shall be observed during installation:

1. Never install telephone wiring during a lightning storm.
2. Never install telephone jacks in wet locations unless the jack is specifically designed for wet locations.
3. Never touch uninsulated telephone wires or terminals unless the telephone line has been disconnected at the network interface.
4. Use caution when installing or modifying telephone lines.

4.2.2 Site Survey

In most cases, a survey of the customer's site is needed to develop cost estimates of the installation. Preliminary information is used to determine the placement of the Main Distribution Frame (MDF). A second visit to the site may be necessary to obtain the exact dimensions of the area selected for MDF, cable lengths, and possible IDF (Intermediate Distribution Frame) locations.

Collected information about the job site generally permits the MDF to be partially assembled at the technician's shop, which helps to minimize time spent at the customer's site.

4.2.3 Site Limitations

Installation of a telephone system is seldom a routine procedure. The uniqueness of each customer situation requires a **tailored** approach to each job. In selecting a permanent site for the MDF, the technician may encounter problems such as, but not limited to, the following:

- Limited space is available and must be used regardless of its suitability.
- The available space may be adequate but may pose one or more environmental hazards.
- The proposed location has limitations such as insufficient lighting or the lack of a suitable ground for grounding the KSUs.

Whatever the nature of the adversities encountered, the technician must make the necessary decisions to arrive at the best possible solution for installing the equipment. It is beyond the scope of this document to cover all possible situations, precautions, and actions.

4.2.4 Site Selection Conditions

KSU Installation Site:

The following conditions should be met at the site selected for the Key Service Unit (KSU).

- The KSUs should be wall mounted to protect against accident or flooding.
- The KSU should not be located directly beneath pipes, due to the possibility of leaks or condensation causing damage to the Electra Professional Level I system equipment.
- The area where the KSU is to be located must be free of corrosive and inflammable gases, excessive chemical or industrial dusts, and other materials that could cause a hazard to personnel or to the proper functioning of the equipment.
- Operating ambient temperature and humidity must be within the limits specified in Section 2.6 - Environmental Conditions in this chapter.
- The operation of the system is virtually noiseless and allows a wide selection of installation sites. Care should be taken to ensure the KSUs do not present a hazard to office traffic. For economy, a central location to minimize cabling is often used.
- The KSU must be located at a site where it can be easily connected to an AC power source.
- The basic KSU weighs approximately 9 lbs. Select a strong wall for mounting.
- Place the KSU according to the following spacing specifications:
 - ▶ Distance between the KSU and the ceiling: 20 in. or more
 - ▶ Distance on both sides of the KSU: 12 in. or more
 - ▶ Distance on front of KSU: 20 in. or more
- Avoid connection of the KSU to an AC receptacle used in common with any other device (e.g., computer, facsimile machine, or copier).

Telephone Installation Site:

The following conditions should be met at the site selected for Multiline Terminals.

- Ensure the cable length and line resistance (loop), between the KSU and the telephones, comply with the specifications shown in Table 1-10 - Multiline Terminal Loop Resistance and Cable Length.

4.2.5 MDF Construction

The Main Distribution Frame (MDF) consists of two different types of standard quick-connect terminal blocks that are mounted on a 3/4" plywood backboard. These blocks should be mounted on standoffs for ease of access. The recommended blocks are: 66M50 for termination of the station cables, and RJ11C/X for termination of the CO/PBX cables.

The Intermediate Distribution Frame (IDF) requires 66M50 blocks.

Both the MDF and IDF use standard bridging clips for each type of terminal block. The bridging clips are used to mate the left half of the terminal block (terminated cable run) to the right half of the terminal block (crossconnection wire). The bridging clips are also useful during troubleshooting to help isolate the cable runs and terminals/telephones from the central equipment and the Central Office Network from the system. (Refer to Figure 1-6 - Typical Full MDF Layout. Also refer to Section 4.3.4 - Wall Mounting the KSU in this chapter.)

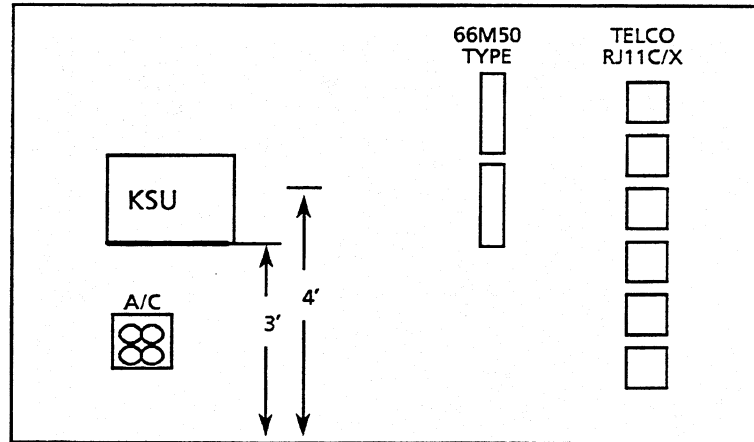

Figure 1-6 Typical Full MDF Layout

4.3 Installing the Key Service Unit (KSU)

4.3.1 Installation Precautions

Before installation and cabling of the KSU, observe these precautions:

- Before starting the work, be sure the KSU power switch is OFF, and disconnect the power cord from the AC outlet.
- Do not directly touch the soldered surfaces of the KTUs with your hands.

4.3.2 KSU

The ESF-C-10 KSU is the system cabinet that houses a power supply, battery backup, and six fixed slots. The KSU is wall mounted. (Refer to Figure 1-7 - Front View of a Fully Loaded KSU.)

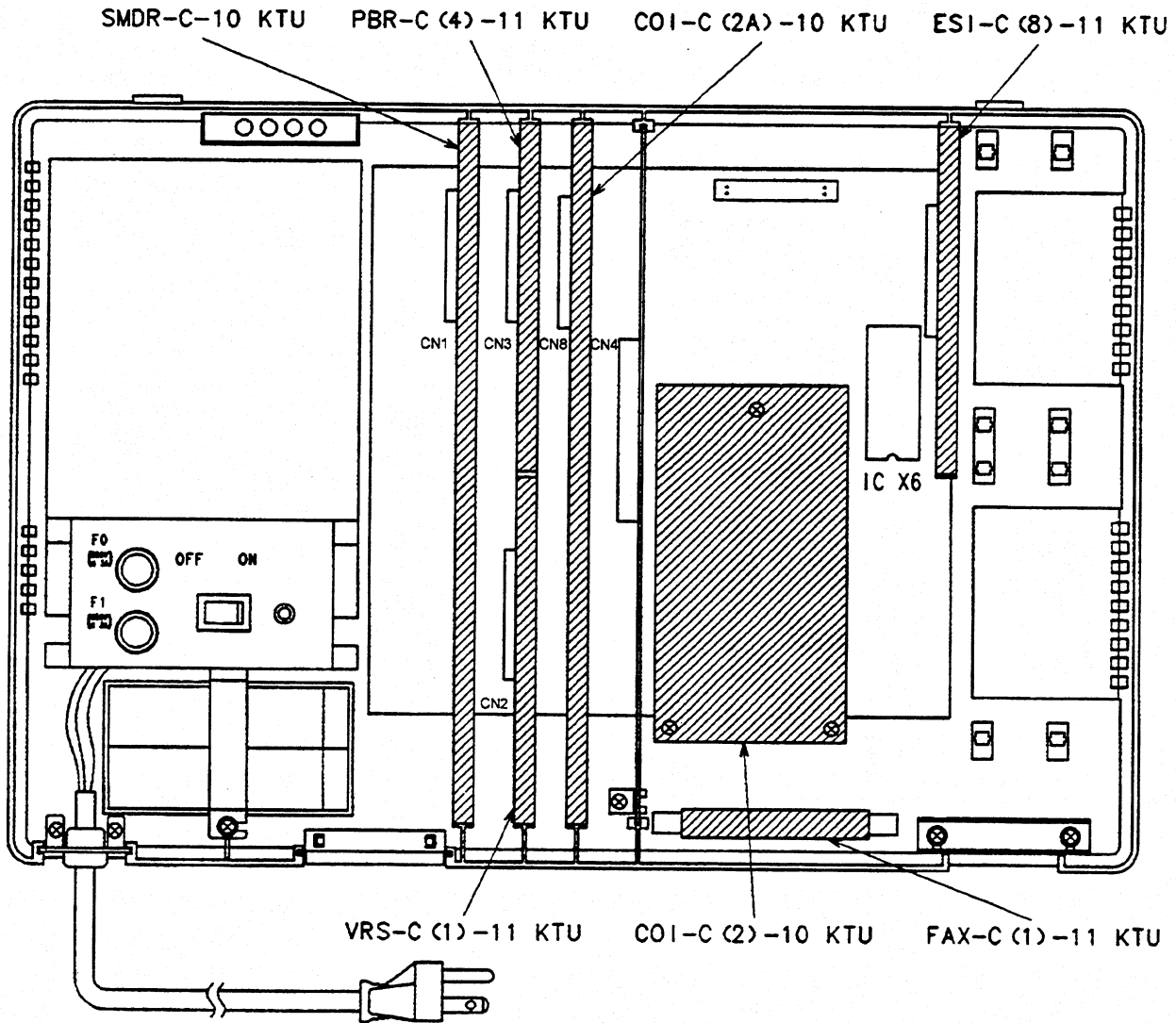

Figure 1-7 Front View of a Fully Loaded KSU

4.3.3 Removing the KSU Cover

Before wall mounting the KSU, the KSU cover must be removed. To remove the cover of the KSU:

1. Loosen the two screws and remove the cover. (Refer to Figure 1-8 - Removing the KSU Cover.)

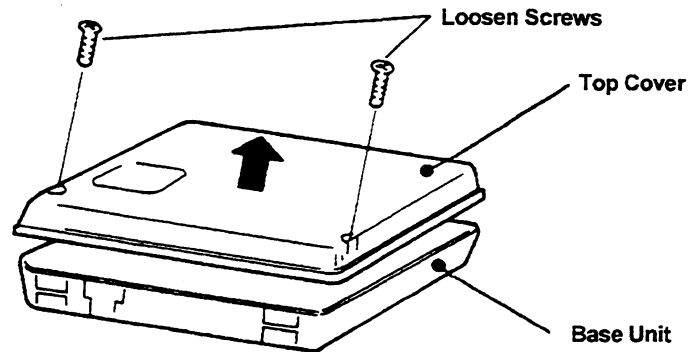

Figure 1-8 Removing the KSU Cover

4.3.4 Wall Mounting the KSU

Before wall mounting the KSU, the wall mounting screws should be attached to plywood (1/2" thick or more) or a sturdy wall.

1. Using two of the four screws (provided with the KSU), attach the wall mount template to the wall. (Refer to Figure 1-9 - Attaching the Wall Mount Bracket for the KSU to the Wall.)

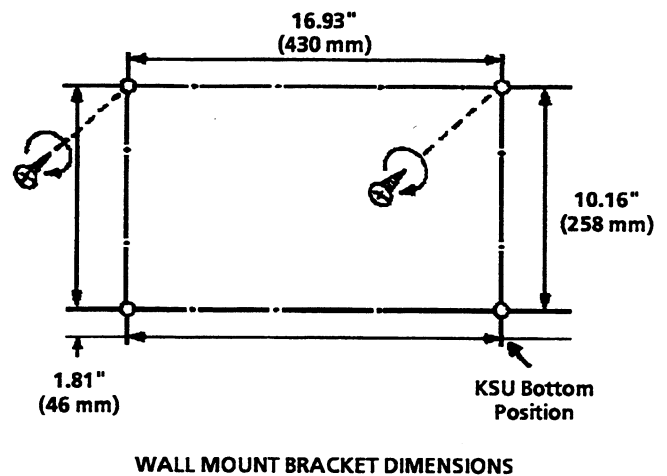

Figure 1-9 Attaching the Wall Mount Bracket for the KSU to the Wall

2. While holding the ESF-C-10 KSU, hang the upper two openings that are located in the KSU base over the wall mount template. (Refer to Figure 1-10 - Attaching the KSU to the Wall Mount Template.)

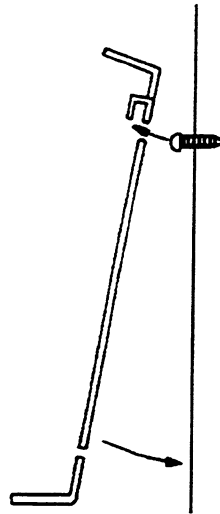

Figure 1-10 Attaching the KSU to the Wall Mount Template

3. Secure the KSU to the wall mount template by inserting one of the other two provided screws in each lower opening in the KSU base. (Refer to Figure 1-11 - Securing the KSU to the Wall Mount Template.)

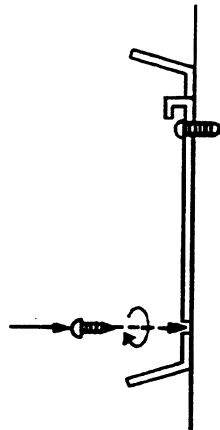

Figure 1-11 Securing the KSU to the Wall Mount Template

4.3.5 Battery Installation

4.3.5.1 Removing the Built-In Batteries

1. Removing the two built-in batteries. (Refer to Figure 1-12 - Removing Batteries.)

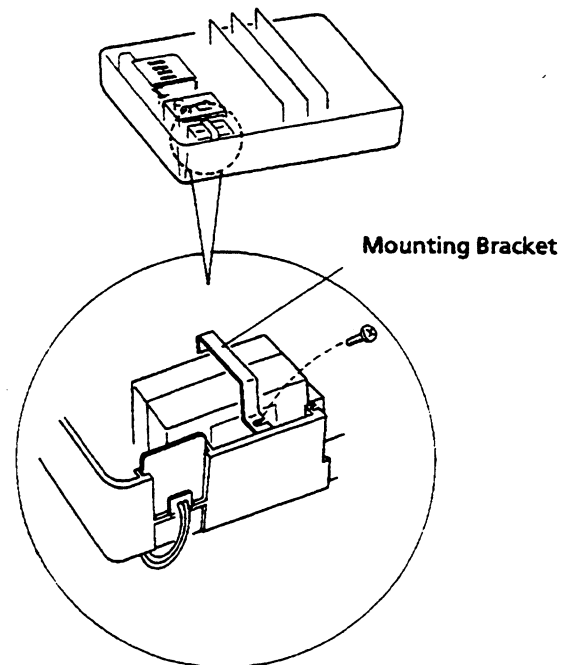

Figure 1-12 Removing Batteries

2. Disconnect CN3 and CN4 from the power supply and unhook the cable from the cable clip. (Refer to Figure 1-13 - Removing the Battery Cables.)

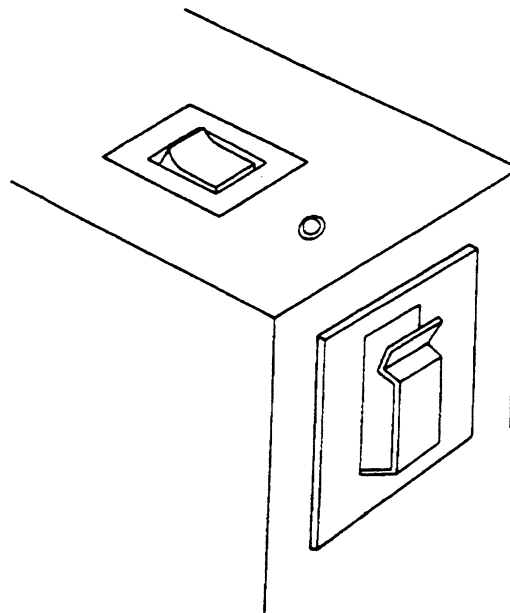
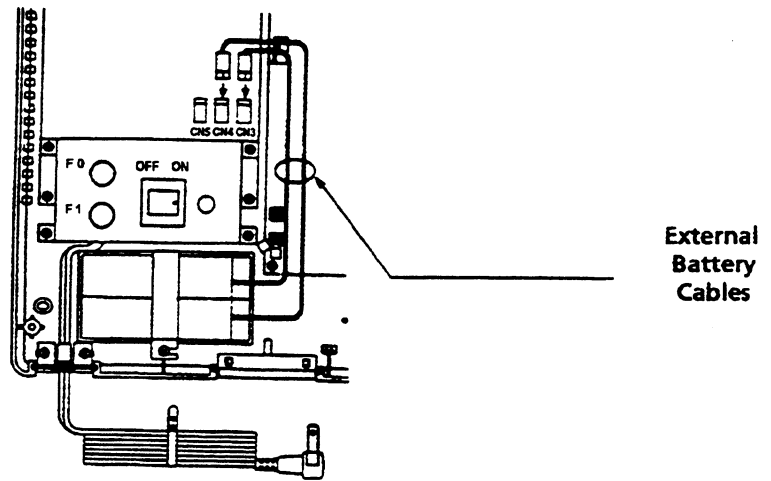

Figure 1-13 Removing the Battery Cables

4.3.5.2 Replacing the Built-In Batteries

1. Place the new batteries in the space provided in the KSU and secure with the metal mounting bracket.
2. Plug in the male cable connectors from the batteries to the CN3 and CN4 connectors on the power supply. Hook the battery cables to the cable clips on the side of the power supply.
3. Turn the KSU to the ON position.

4.3.5.3 Connecting External Batteries

1. Disconnect the built-in batteries from the power supply. (Refer to Figure 1-14 - Disconnecting Built-In Batteries.)

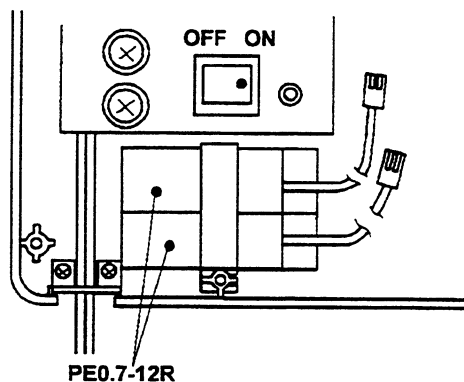

Figure 1-14 Disconnecting Built-In Batteries

2. Mount the external batteries and connect to CN3 and CN4 using the external battery cable assembly. (Refer to Figure 1-15 - Connecting External Batteries.)

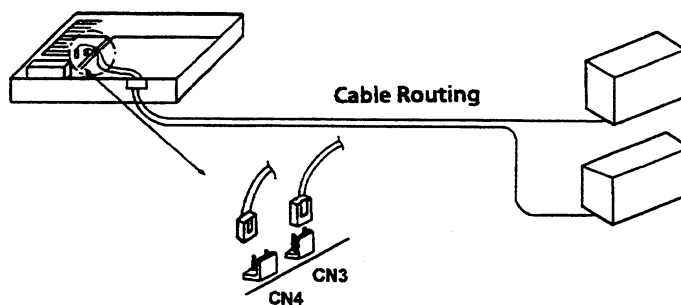

Figure 1-15 Connecting External Batteries

4.3.5.4 Replacing the Battery for System Memory

1. Locate and remove the lithium battery in the upper right-hand corner of the KSU. (Refer to Figure 1-16 - Lithium Battery Location.)

ESF-C-10 KSU

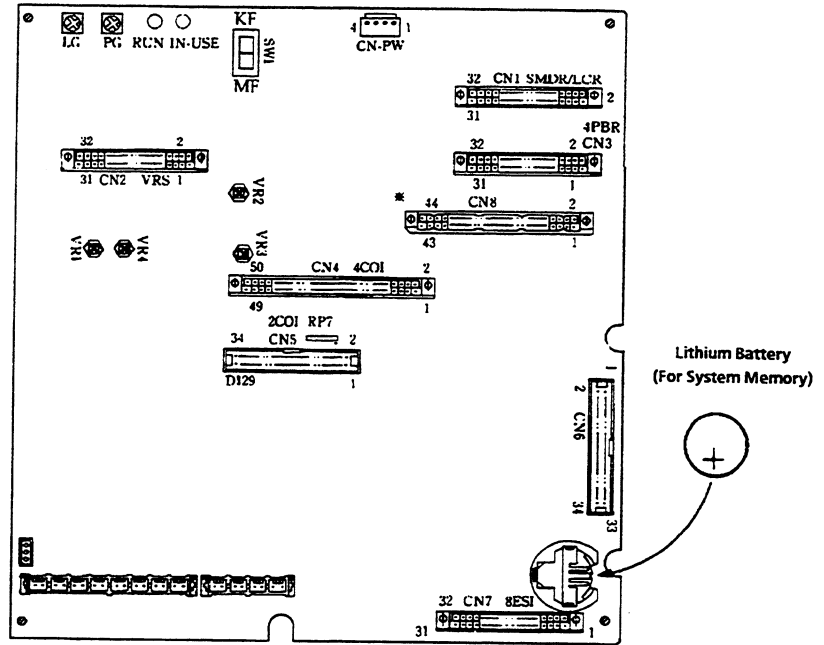

Figure 1-16 Lithium Battery Location

2. Remove the old battery and replace it with the new battery. (Refer to Figure 1-17 - Replacing Lithium Battery.)

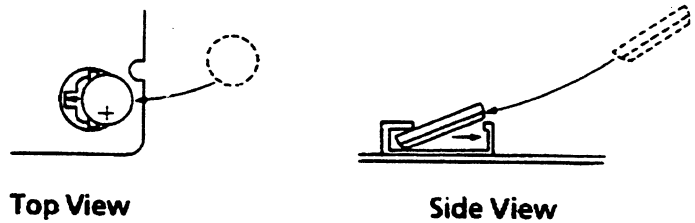

Figure 1-17 Replacing Lithium Battery

4.3.6 Grounding Requirements

The KSU must be properly grounded. If circuit ground is not available at the dedicated AC outlet, the following steps should be taken:

1. Provide a suitable cold water pipe ground in accordance with the local operating telephone company procedures.
2. If no water pipe ground is available, a ground rod should be installed in accordance with the local operating telephone company procedures.
3. Where a ground (other than conduit ground) is used, a grounding terminal is provided on the ESF-C-10 KSU. (Refer to Figure 1-18 - KSU Grounding.)

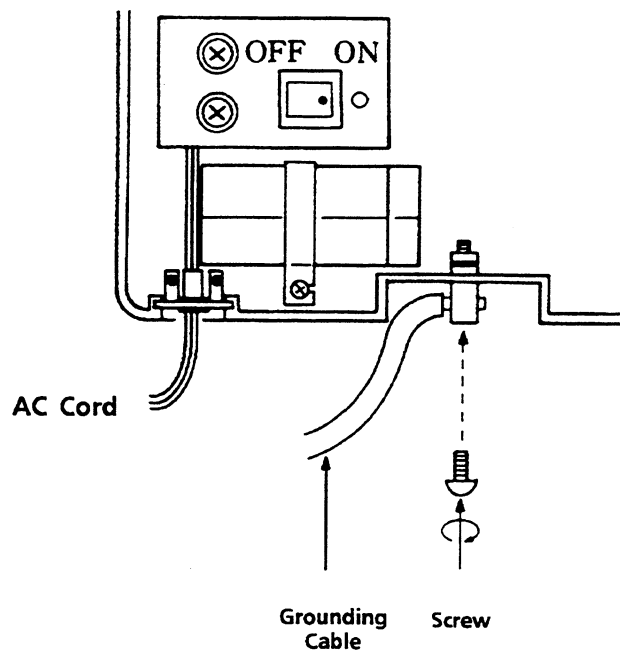

Figure 1-18 KSU Grounding

SECTION 5 INSTALLING A KEY TELEPHONE UNIT (KTU)

5.1 General Information

5.1.1 Installation Precautions

Before installation of the KTUs observe these precautions:

1. To prevent accidental damage to equipment, the power must be OFF during installation and maintenance.
2. The KTUs used in this system make extensive use of CMOS technology. CMOS technology is very susceptible to static; therefore, extreme care must be taken to avoid static discharge when handling KTUs.

5.1.2 KTU Installation

Make any connections and switch settings on the KTUs before inserting them in the KSU. (Refer to Sections 5.2 - Common Control KTU, 5.3 - Interface KTUs, and 5.4 - Optional KTUs for the switch settings for individual KTUs. Also refer to Figure 1-19 - Installing a Vertically Mounted KTU.)

CAUTION

When a KTU is installed or removed, ensure that the power switch of the KSU is in the OFF position.

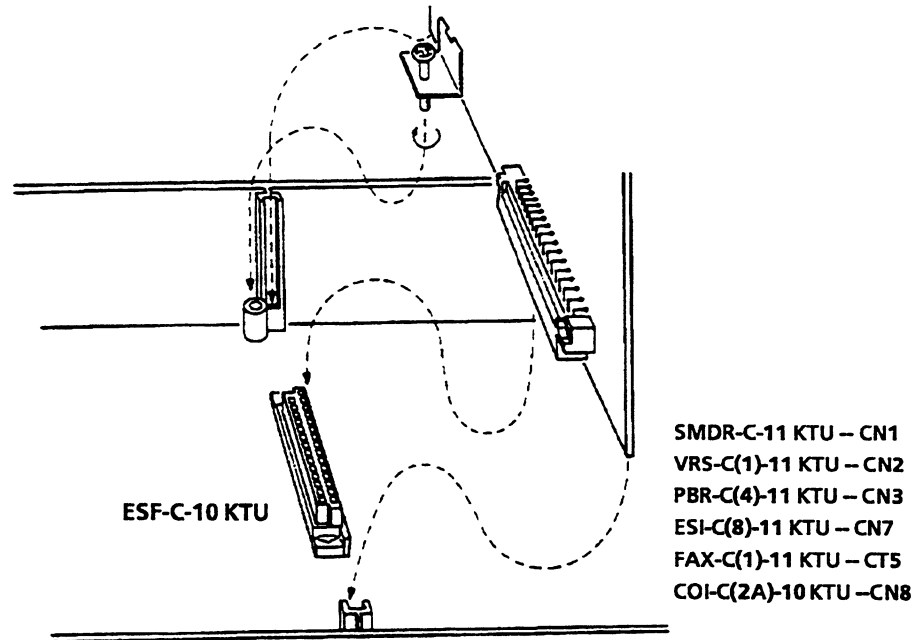

Figure 1-19 Installing a Vertically Mounted KTU

5.1.3 Mounting the KTUs

Be sure to mount the KTU(s) in the correct position inside the KSU. Make any connections and switch settings prior to mounting the KTU.

5.1.4 Installing COI-C(2)-10 KTU/COI-C(2A)-10 KTU

5.1.4.1 Installing COI-C(2)-10 KTU

Be sure to mount the KTU in the correct position inside the KSU. Make any corrections and switch settings prior to mounting the KTU. [Refer to Figure 1-20 - Installing COI-C(2)-10 KTU.]

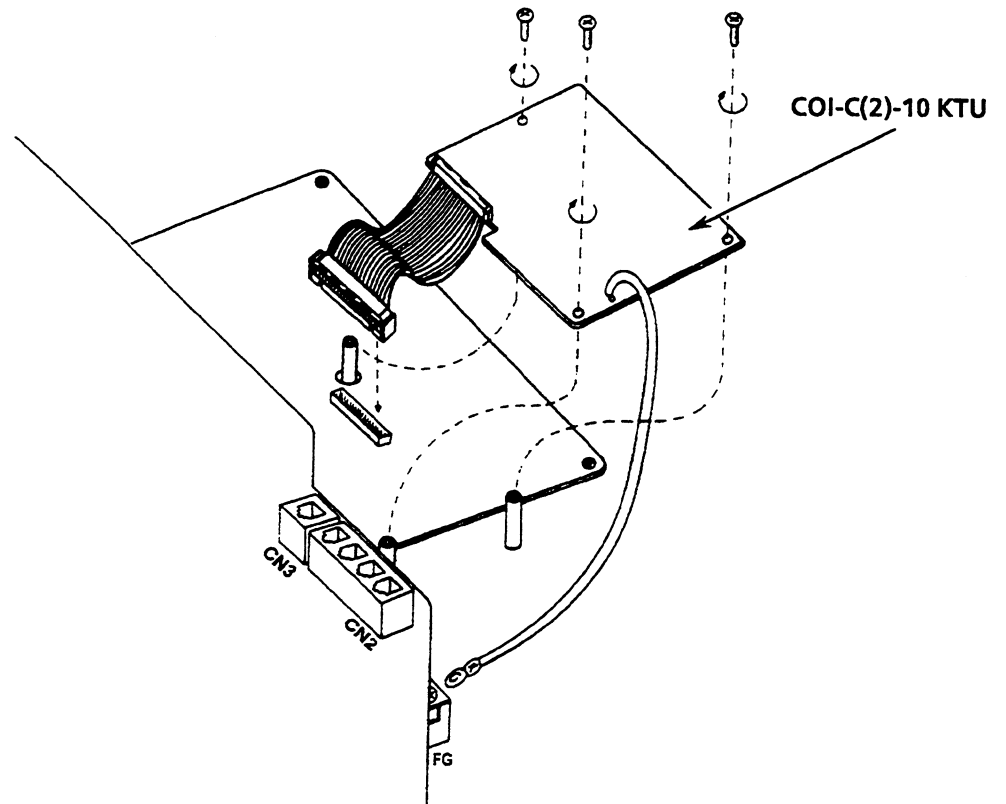

Figure 1-20 Installing COI-C(2)-10 KTU

5.1.4.2 Installing COI-C(2A)-10 KTU

Be sure to mount the KTU in the correct position inside the KSU (CN8) and connect the ground wire. Make any switch settings prior to mounting the KTU. [Refer to Figure 1-21 - Installing COI-C(2A)-10 KTU.]

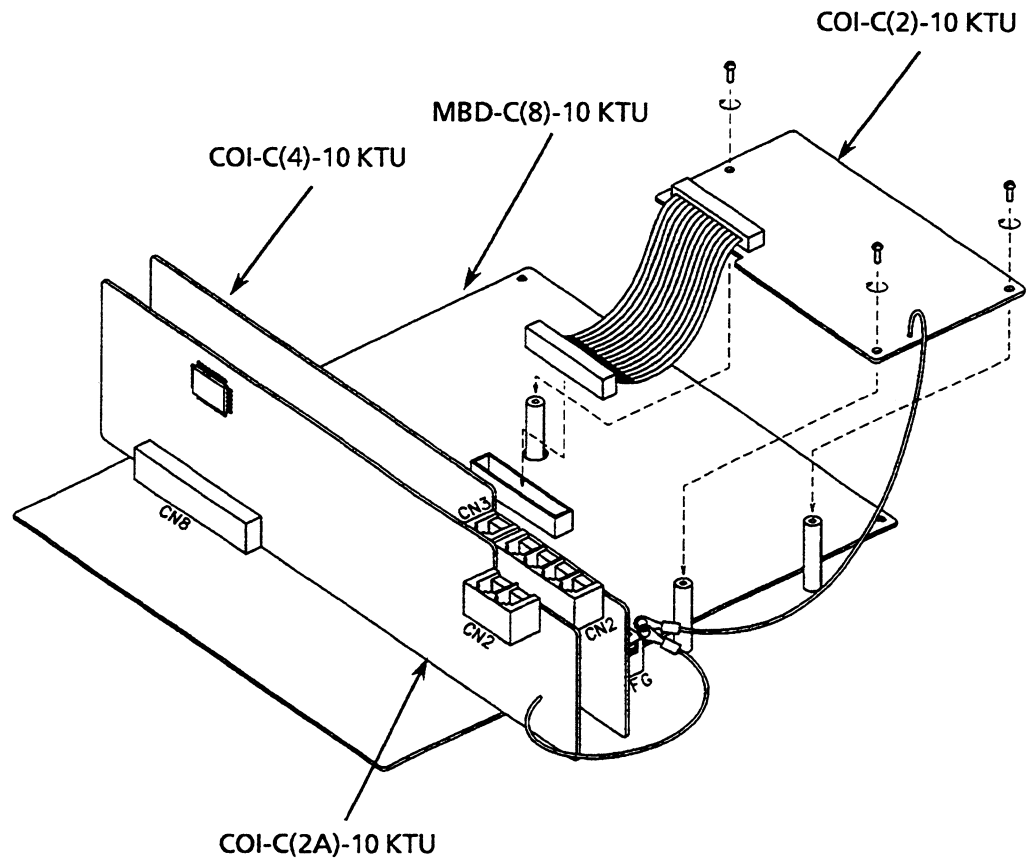

Figure 1-21 Installing COI-C(2A)-10 KTU

5.2 Common Control KTU

The CPU is the central processing unit. An 8-bit microprocessor executes the programs stored on the ROM ICs to control the whole system, while transferring data to and from other KTUs.

The KSU consists of a main control section and a Time Division Switch (TDSW) section. It also has a BGM/MOH interface circuit, four general purpose relay circuits, two 4-party conference circuits, two doorphone circuits, four CO/PBX interface circuits, eight station interface circuits, and one power failure transfer circuit.

A switch (SW1) is provided for selecting key function or multi-function operations.

The RAM memory, on the CPU, is backed up with a non-rechargeable battery, which can retain the memory for up to 18 months.

Switch Settings:

Before programming System Data, the non-rechargeable lithium battery must be installed to allow memory content retention in case of a power failure or brownout. Failure to activate the backup battery circuit may cause System Data to reset to the default values, status of all stations to reset to the default values, and data programmed on the station to clear if a power failure or brownout occurs. (If programming using a Multiline Terminal, refer to Chapter 2 - Programming in this manual for instructions.)

When the KSU is removed for long-term storage, remove the lithium battery. This prevents the battery from constantly discharging. The fully-charged battery retains

memory contents for approximately 18 months. (Refer to Figure 1-22 - KSU Switch Settings and Table 1-21 - KSU Adjustments.)

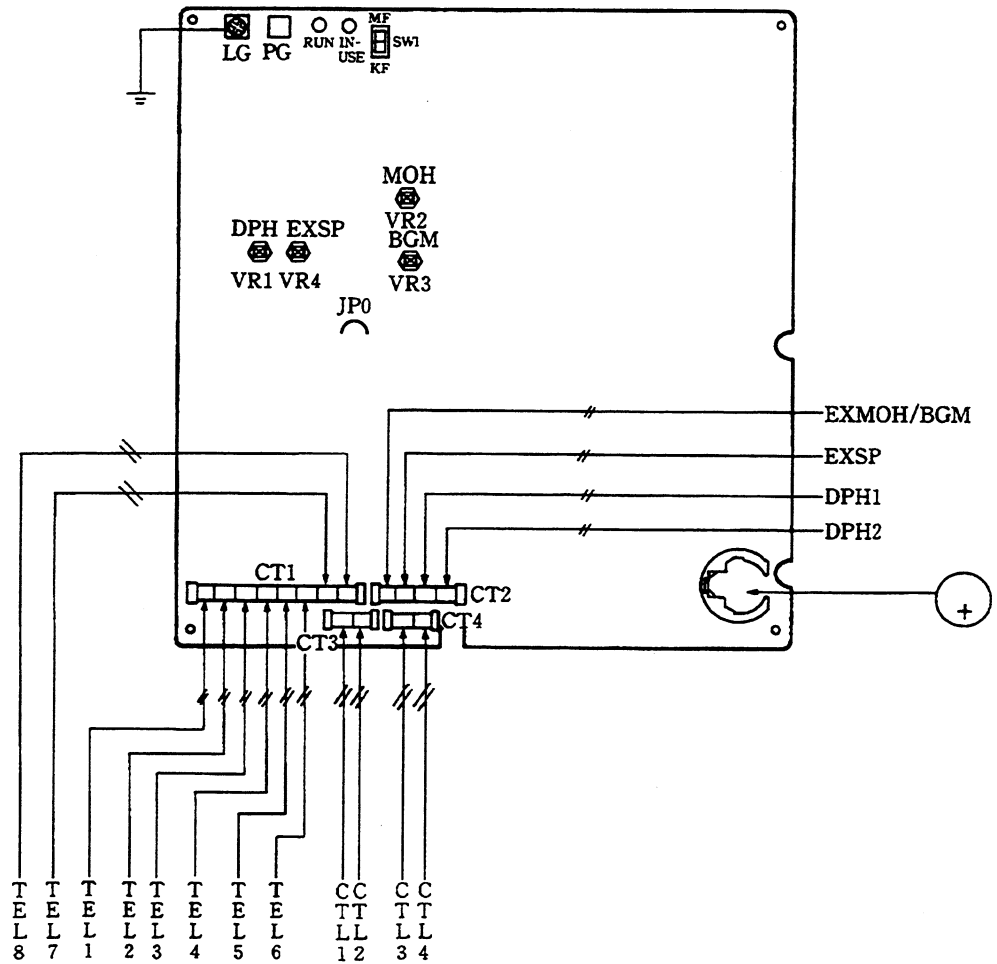

The operation verification LED (RUN) always flashes when the system is in normal operation, and is on steady when the system is reset.

Figure 1-22 KSU Switch Settings

Table 1-21 KSU Adjustments

Adjustment Item	Name of Switch	Initial Setting	Adjustment/Description
Memory Backup	N/A	OUT	Install the Lithium Battery
Volume Controls	VR1	N/A	Doorphone Speaker Volume
	VR2	N/A	Internal MOH Volume Adjustment (Note 1)
	VR3	N/A	BGM/MOH Volume Adjustment (External MOH)
	VR4	N/A	External Page Volume Adjustment
DIP Switch	DIP SW1	ON	OFF: Multi-Function System ON: Key Function System (Note 2)
Connectors	CN-PW	DC Input	
	CN1	SMDR	
	CN2	VRS	
	CN3	PBR	
	CN4	COI-C(4) (4 Ports)	
	CN5	COI-C(2) (2 Ports)	
	CN6	Not Used	
	CN7	ESI (8 Ports)	
	CN8	COI-C(2A) (2 Ports)	
TP	TP1	N/A	Ground Test Point
BN	BN 1 ~ 4	OFF	CO/PBX Loop Resistance Adjustment
Jumper	JP0	Strapped	Cut strap if external paging amplifier is less than 3K ohms

Note 1: Internal MOH has two melodies. Select the following melodies in System Programming:

1. Melody Fair
2. Let It Be

Note 2: Refer to Section 1.2.1 - Company Notification in this chapter.

5.3 Interface KTUs

5.3.1 ESI-C(8)-11 KTU

This KTU is an interface for Multiline Terminals and SLT Adaptors. The ESI allows connection of eight Multiline Terminals. [Refer to Figure 1-23 - ESI-C(8)-11 KTU.]

Only one ESI-C(8)-11 KTU can be installed in the system.

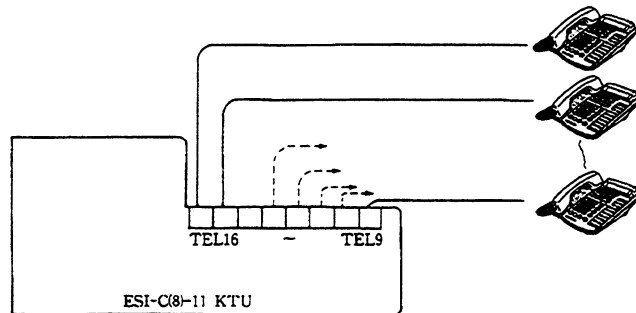

Figure 1- 23 ESI-C(8)-11 KTU

5.3.2 COI-C(2)-10 KTU/COI-C(2A)-10 KTU

5.3.2.1 COI-C(2)-10 KTU

The Central Office Interface Unit (COI) contains circuitry for outside ring detection, hold, dialing, and control function.

Each COI-C(2)-10 KTU provides two identical circuits to serve up to two CO/PBX trunks which can be any mix of Loop Start Trunks with DTMF or Dial Pulse dialing. In addition, Tip and Ring electrical fuses (posistors) are provided to comply with UL 1459 2nd Edition requirements.

Note: BN1 and BN2 are used to set the CO/PBX loop resistance. Set to the OFF position for 800 ohms or less or to the ON position for more than 800 ohms of loop resistance.

Only one COI-C(2)-10 KTU can be installed in the KSU. [Refer to Figure 1-24 - COI-C(2)-10 KTU.]

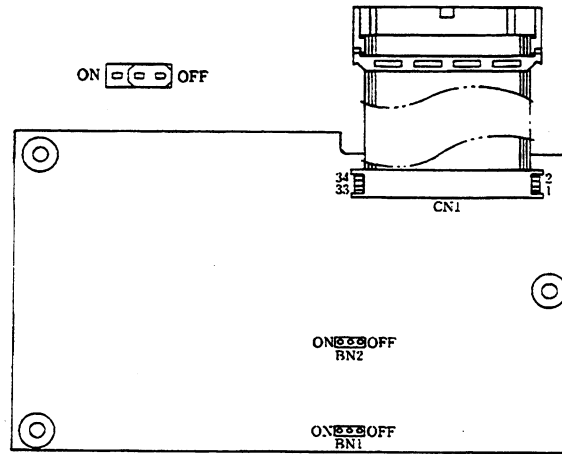

Figure 1-24 COI-C(2)-10 KTU

5.3.2.2 COI-C(2A)-10 KTU

The Central Office Interface Unit (COI) contains circuitry for outside ring detection, hold, dialing, and control function.

Each COI-C(2A)-10 KTU provides two identical circuits to serve up to two CO/PBX trunks which can be any mix of Loop Start Trunks with DTMF or Dial Pulse dialing. In addition, Tip and Ring electrical fuses (posistors) are provided to comply with UL 1459 2nd Edition.

Note: BN100 and BN200 are used to set CO/PBX loop resistance. Set to the OFF position for 800 ohms or less or to the ON position for more than 800 ohms loop resistance.

Only one COI-C(2A)-10 KTU can be installed in the KSU. Software version 3.0 or higher is required. [Refer to Figure 1-25 - COI-C(2A)-10 KTU.]

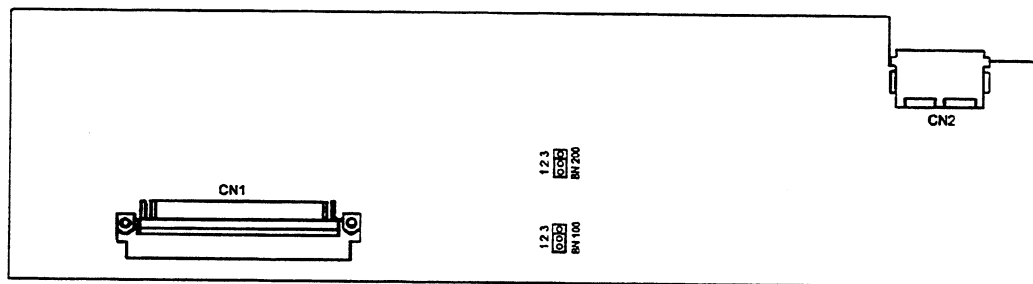

Figure 1-25 COI-C(2A)-10 KTU

5.4 Optional KTUs

5.4.1 VRS-C(1)-11 KTU

The VRS-C(1)-11 KTU has four functions. The Automated Attendant allows incoming calls to be answered automatically. Callers receive a message and can be forwarded to the applicable party. A customized message is played to parties placed on hold, parties manually answered, or parties automatically answered; after the message is played the call is disconnected. Internal messaging is also available via the VRS-C(1)-11 KTU.

Each VRS KTU has one circuit. Only one VRS-C(1)-11 KTU can be installed in the system. [Refer to Figure 1-26 - VRS-C(1)-11 KTU.]

To install the VRS-C(1)-11 KTU:

1. Turn the main power OFF.
2. Move JP1 on the VRS KTU to the ON position.
3. Install the VRS KTU in the applicable interface slot on the KSU.
4. Turn the main power ON.
5. Proceed with programming. (Refer to Chapter 2 - Programming, in this manual, for instructions.)

Note: JP1 is used to turn the battery on or off.

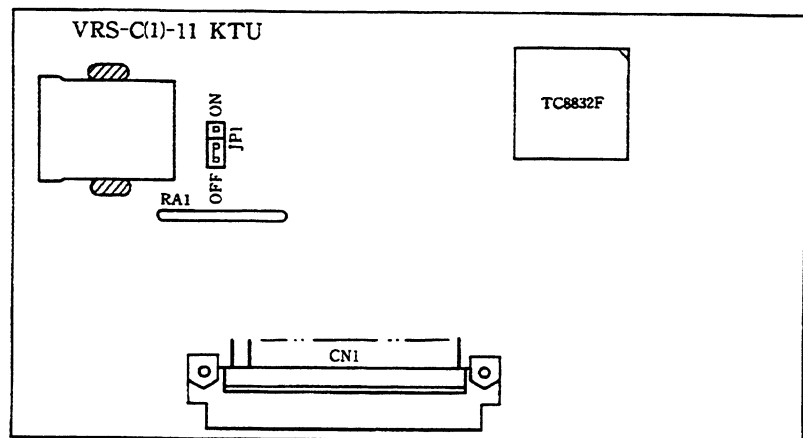

Figure 1-26 VRS-C(1)-11 KTU

5.4.2 PBR-C(4)-11 KTU

The Push Button Receiver (PBR) KTU detects and translates DTMF tones generated by Single Line Telephones, modems, or other devices. The PBR KTU has four circuits.

Only one PBR-C(4)-11 KTU can be installed in the system. [Refer to Figure 1-27 - PBR-C(4)-11 KTU.]

To install the PBR-C(4)-11 KTU:

1. Turn the main power OFF.
2. Install the PBR KTU in the applicable interface slot on the KSU.
3. Turn the main power ON.

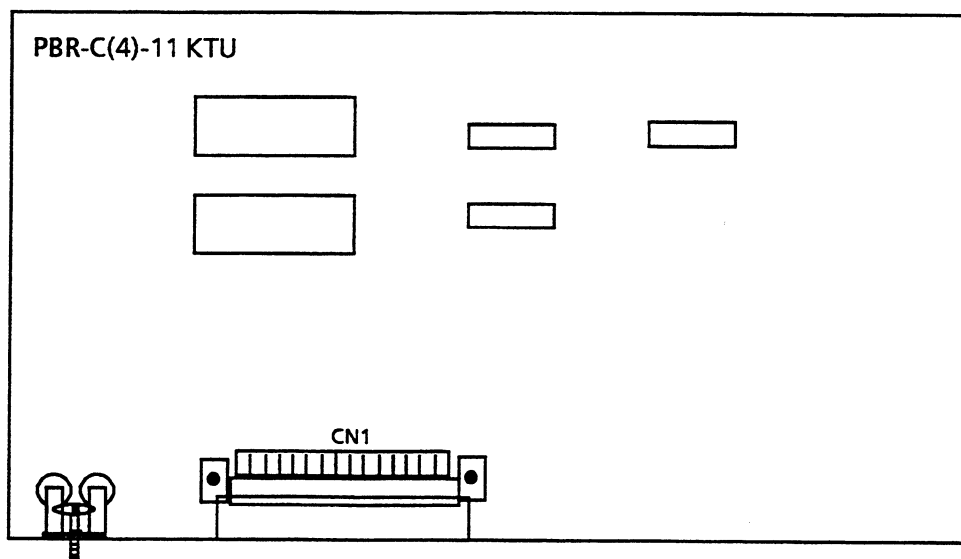

Figure 1-27 PBR-C(4)-11 KTU

5.4.3 SMDR-C-10 KTU

The SMDR-C-10 KTU outputs the Station Message Detail Recording (SMDR) via the RS-232 cable to a printer. NEC recommends using a custom-made cable. (Refer to Table 1-22 - SMDR and Printer Connections.)

Only one SMDR-C-10 KTU can be installed in the system. (Refer to Figure 1-28 - SMDR-C-10 KTU Cable and Table 1-22 - SMDR and Printer Connections.)

To install the SMDR-C-10 KTU:

1. Turn the main power OFF.
2. Move TP1 on the SMDR KTU to the ON position.
3. Install the included SMDR printer cable.
4. Install the SMDR KTU in the applicable interface slot on the KSU.
5. Install the custom-made RS-232 cable between the SMDR KTU and the printer.
6. Turn the main power ON.
7. Proceed with programming. (Refer to Chapter 2 - Programming, in this manual, for instructions.)

Note: TP1 is used to turn the battery on or off.

SMDR RS-232C Interface Specifications

- Data Length: 8 bit
- Parity: None
- Stop Bit: 2
- Baud Rate: 600, 1200, 2400, or 4800
- Synchronization: Asynchronous

Note: Set up the printer using the XON/OFF or ETX/ACK protocol.

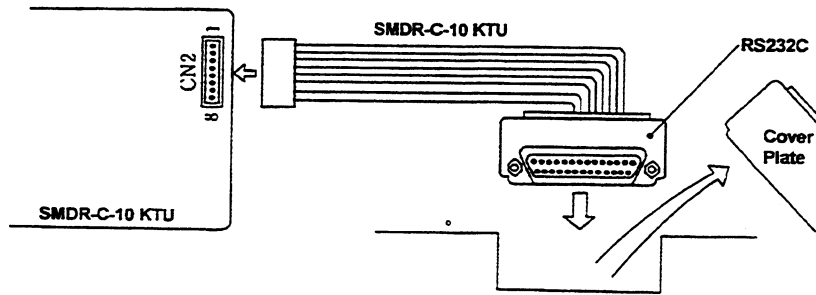

Figure 1- 28 SMDR-C-10 KTU Cable

Table 1-22 SMDR and Printer Connections

RS-232			PRINTER	
TXD	2	→	3	RXD
CTS	5	←	20	DTR
SG	7	↔	7	SG

Switch Settings/LED Indications:

When LED1 (red) is flashing, the SMDR-C-10 KTU is exchanging communications data with the CPU. When LED2 (red) is on steady, the SMDR-C-10 KTU function is outputting the call record.

SW1 adjusts the baud rate to the locally provided printer. TP1 turns the battery on or off. TP2 is for internal use only. Do not adjust this test point. (Refer to Figure 1-29 - SMDR-C-10 KTU Switch Layout.)

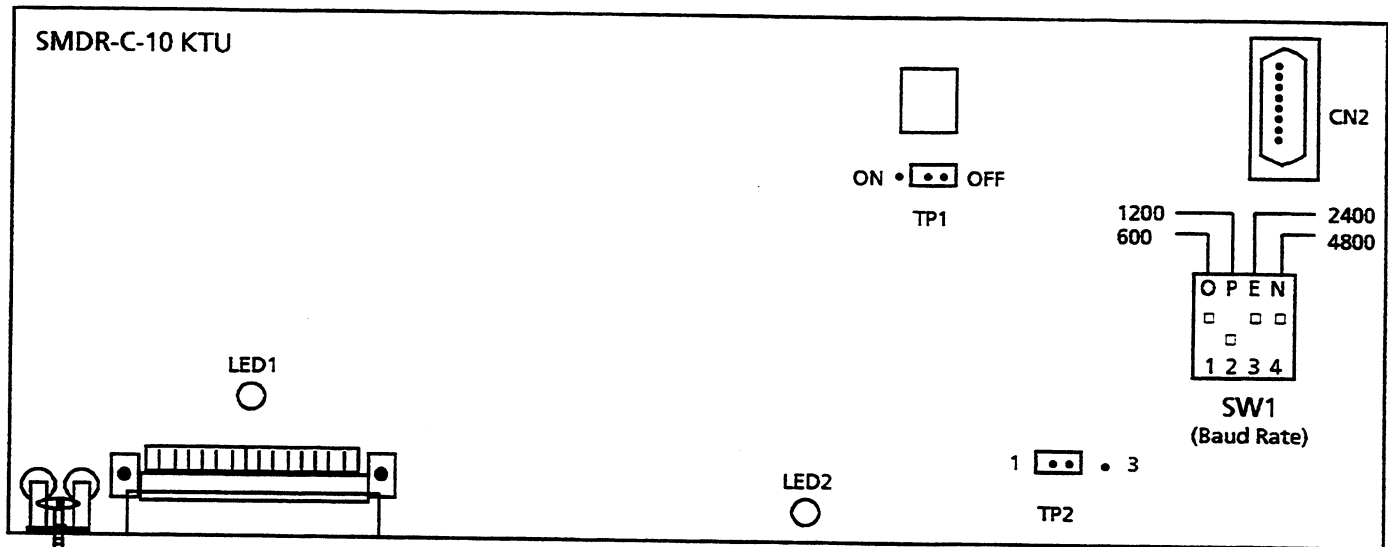

Figure 1- 29 SMDR-C-10 KTU Switch Layout

5.4.4 Installing the FAX-C(1)-11 KTU

The FAX-C(1)-11 KTU is required for the facsimile connection. Software version 2.0 or higher is required. (Refer to Figure 1-7 - Front View of a Fully Loaded KSU.)

1. Install the stand-offs and the FAX-C(1)-11 KTU into the ESF-C-10 KSU. (Refer to Figure 1-30 - FAX-C(1)-11 KTU Installation.)

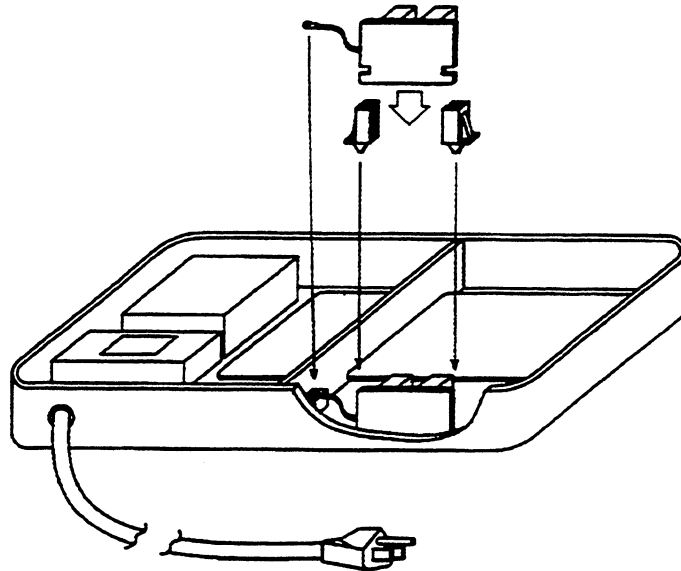

Figure 1-30 FAX-C(1)-11 KTU Installation

2. Connect all six connectors in the FAX-C(1)-11 KTU to the applicable locations. (Refer to Figure 1-31 - Fax Connection.)
3. Turn the system ON.
4. Proceed with programming. (Refer to Chapter 2 - Programming, in this manual, for detailed instructions.)

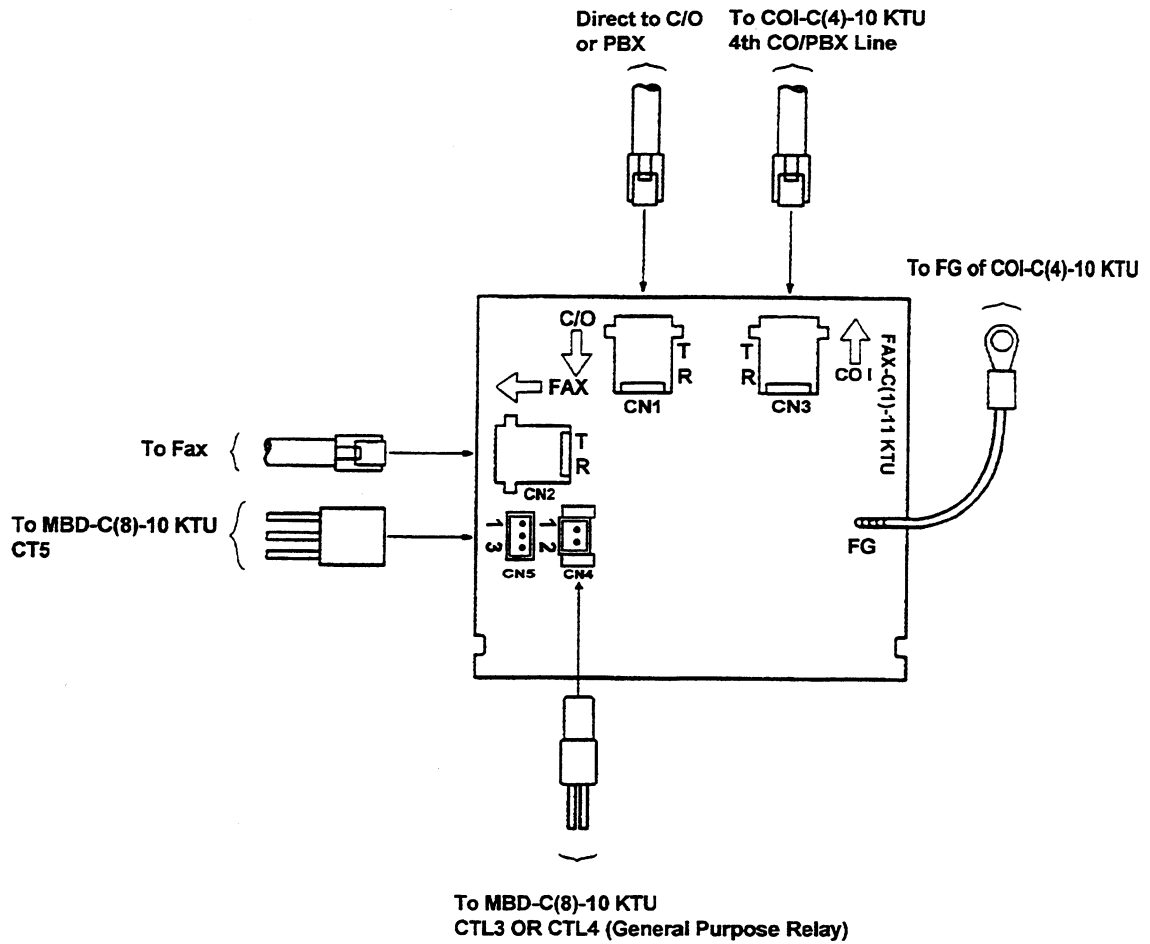
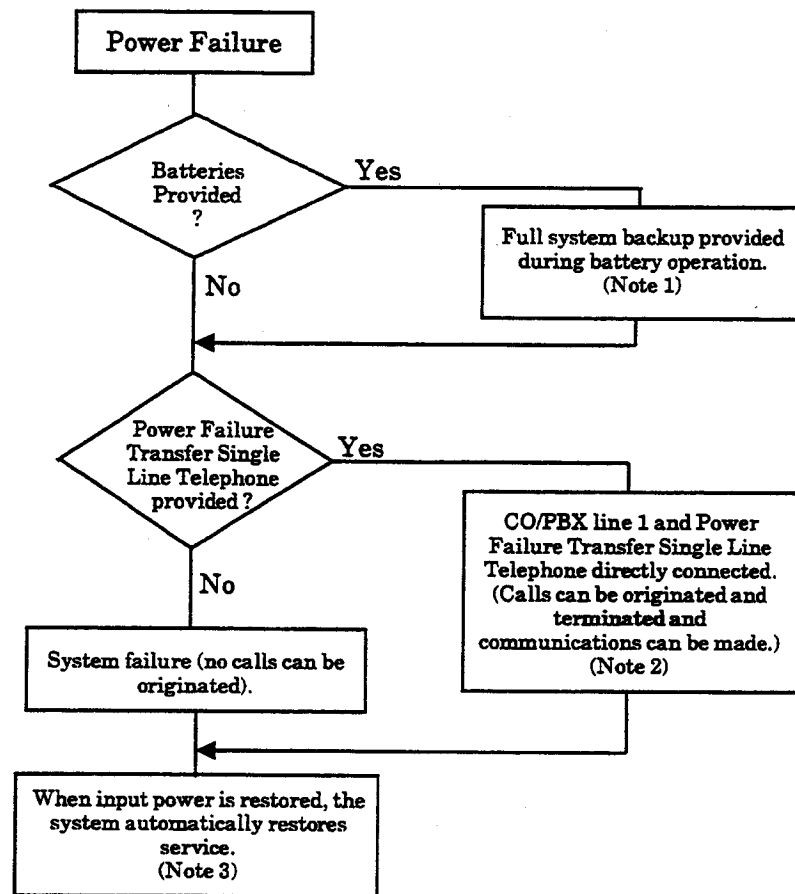

Figure 1-31 Fax Connection

5.5 Power Failure Backup

5.5.1 Operation if Power Fails

If power fails, the built-in batteries provide full backup of system service for about 10 minutes. Longer backup is possible if locally-provided external batteries are used (the period depends on the system configuration and service conditions). The Power Failure Transfer (PFT) Single Line Telephone Interface Circuit is mounted in the KSU. The KSU connects a Single Line Telephone directly to CO/PBX line 1 to allow origination and termination of calls. (Refer to Figure 1-32 - Power Failure Backup Flowchart.)



Note 1: The backup period for the Electra Professional Level I system is approximately 10 minutes with built-in batteries or longer with external batteries added.

Note 2: All calls in progress are interrupted when switch-over is made to connect the Power Failure Transfer Single Line Telephone directly to CO/PBX line 1. This occurs after backup batteries expire.

Note 3: If the power switch of the KSU is in the OFF position, the system does not automatically restore service.

Figure 1-32 Power Failure Backup Flowchart

5.5.2 Operation When Input Power Is Restored

When input power is restored, the system automatically resets and restores service.

5.5.3 Single Line Telephone for Power Failure Transfer

A Single Line Telephone can be used as a Power Failure Transfer telephone.

5.5.3.1 Connections

Connect the SLT to the modular jack, on the COI(4) Unit, designated for PFT. Only one PFT circuit is provided for CO/PBX line 1. (Refer to Figure 1-33 - Connecting a Single Line Telephone for Power Failure Transfer.)

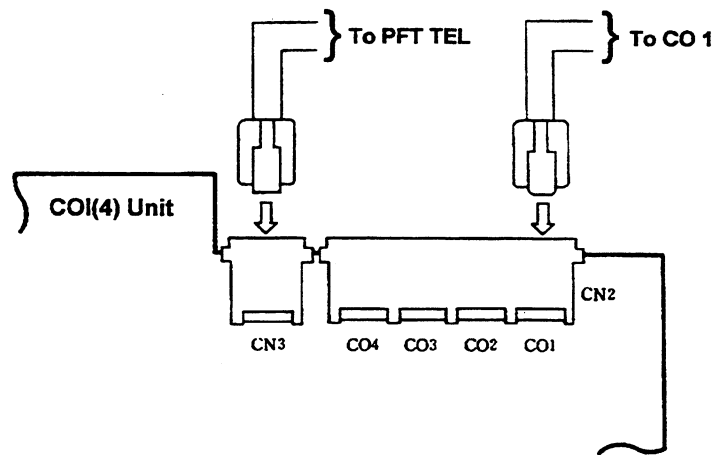

Figure 1-33 Connecting a Single Line Telephone for Power Failure Transfer

5.5.3.2 Procedure

To use the Single Line Telephone for power failure transfer during a power failure, proceed as follows:

- Originating
 1. Lift the handset. (Ensure that dial tone is heard.)
 2. Dial the desired number.
 3. Talk.
- Receiving
 1. Receive ringing tone.
 2. Lift the handset and answer.

Note: The Single Line Telephone, designated for Power Failure Transfer, must match the dialing type of CO line 1 (10 pps, 20 pps, or DTMF) where it is connected.

SECTION 6 CABLE CONNECTIONS

6.1 General Information

6.1.1 Connection Requirements

The KSU is connected with each of the Multiline Terminals, Single Line Telephones, optional equipment, or CO by a separate twisted-pair cable through the MDF.

6.1.2 Cabling Precautions

When selecting cables and the MDF, future expansion or assignment changes should be given due consideration. Avoid running cables in the following places:

- A place exposed to wind or rain.
- A place near heat radiating equipment or where the quality of PVC covering could be affected by gases and chemicals.
- An unstable place subject to vibration.

6.2 Wiring Between the KSU and the MDF

6.2.1 KSU Cables

The KSU is equipped with an MDF Cable Assembly. NEC recommends using the MDF Cable Assembly to connect the Multiline Terminals, Single Line Telephones, or CO lines. (Refer to Table 1-23 - Connection Information/Connection and Port Relationships and Figure 1-34 - Cable Assembly Diagram.) When installing Single Line Telephones with PFT and other optional equipment, NEC provides the connector; however, the cabling must be locally provided.

Table 1-23 Connection Information/Connection and Port Relationships

Connectors		MDF Pin No.	Running Cable	ETW Station Cable	DTU Station Cable	Lead Functions Multiline Terminals		
BASIC KSU	A	10	26 1	WH-BL BL-WH	BK YL	RD GN	DT DR	
		11	27 2	WH-OR OR-WH	BK YL	RD GN	DT DR	
	B	12	28 3	WH-GN GN-WH	BK YL	RD GN	DT DR	
		13	29 4	WH-BR BR-WH	BK YL	RD GN	DT DR	
	C	14	30 5	WH-SL SL-WH	BK YL	RD GN	DT DR	
		15	31 6	RD-BL BL-RD	BK YL	RD GN	DT DR	
	D	16	32 7	RD-OR OR-RD	BK YL	RD GN	DT DR	
		17	33 8	RD-GN GN-RD	BK YL	RD GN	DT DR	
ESI-C(8)-11	E	18	34 9	RD-BR BR-RD	BK YL	RD GN	DT DR	
		19	35 10	RD-SL SL-RD	BK YL	RD GN	DT DR	
	F	20	36 11	BK-BL BL-BK	BK YL	RD GN	DT DR	
		21	37 12	BK-OR OR-BK	BK YL	RD GN	DT DR	
	G	22	38 13	BK-GN GN-BK	BK YL	RD GN	DT DR	
		23	39 14	BK-BR BR-BK	BK YL	RD GN	DT DR	
	H	24	40 15	BK-SL SL-BK	BK YL	RD GN	DT DR	
		25	41 16	YL-BL BL-YL	BK YL	RD GN	DT DR	
	BASIC KSU	I	BGM MOH	42 17	YL-OR OR-YL	BK YL	RD GN	DT DR
			EXSP	43 18	YL-GN GN-YL	BK YL	RD GN	DT DR
J		DPH 1	44 19	YL-BR BR-YL	BK YL	RD GN	DT DR	
		DPH 2	45 20	YL-SL SL-YL	BK YL	RD GN	DT DR	
K		CTL 1	46 21	VI-BL BL-VI	BK YL	RD GN	DT DR	
		CTL 2	47 22	VI-OR OR-VI	BK YL	RD GN	DT DR	
L		CTL 3	48 23	VI-GN GN-VI	BK YL	RD GN	DT DR	
		CTL 4	49 24	VI-BR BR-VI	BK YL	RD GN	DT DR	
Not Used		50 25	VI-SL SL-VI	NA	NA	NA		

Note: CO Lines are modular and recommended to be directly connected to the RJ11X from the Central Office.

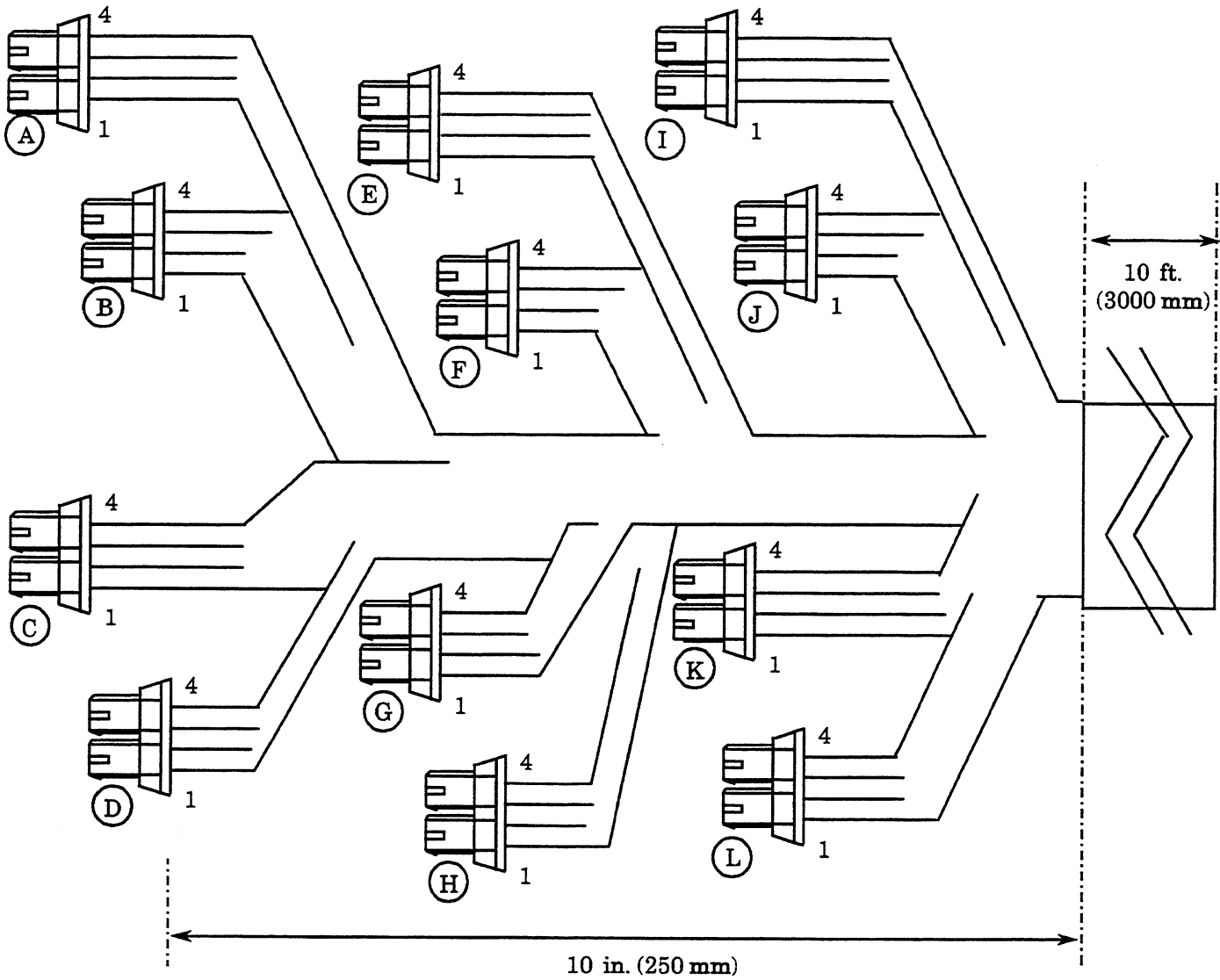

CABLE COLORS						
Pin	A	B	C	D	E	F
1	WH-BL	WH-GN	WH-SL	RD-OR	RD-BR	BK-BL
2	BL-WH	GN-WH	SL-WH	OR-RD	BR-RD	BL-BK
3	WH-OR	WH-BR	RD-BL	RD-GN	RD-SL	BK-OR
4	OR-WH	BR-WH	BL-RD	GN-RD	SL-RD	OR-BK
Pin	G	H	I	J	K	L
1	BK-GN	BK-SL	YL-OR	YL-BR	VI-BL	VI-GN
2	GN-BK	SL-BK	OR-YL	BR-YL	BL-VI	GN-VI
3	BK-BR	YL-BL	YL-GN	YL-SL	VI-OR	VI-BR
4	BR-BK	BL-YL	GN-YL	SL-YL	OR-VI	BR-VI

Figure 1-34 Cable Assembly Diagram

6.2.1.1 Modular Terminal Connections

When connecting Multiline Terminals to the MDF or IDF, individually twisted 1-pair cabling must be used. (Refer to Table 1-23 - Connection Information/Connection and Port Relationships for lead functions.) Refer to Figure 1-35/1-36 - Modular Terminal for Connection of DTU/ETW Multiline Terminals and SLT Adaptor for station modular jack (RJ11C/W) connection.

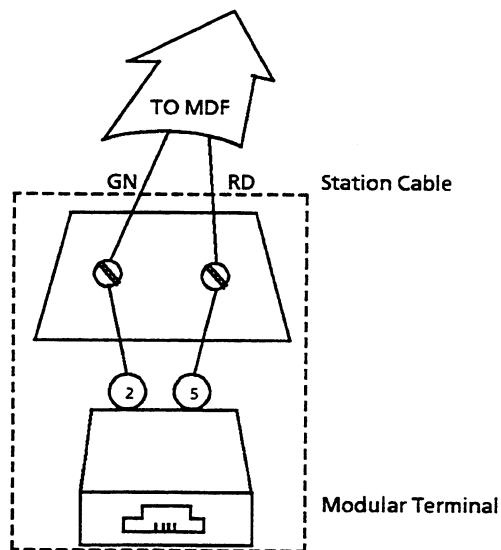

Figure 1-35 Modular Terminal for Connection of DTU Multiline Terminals and SLT Adaptor

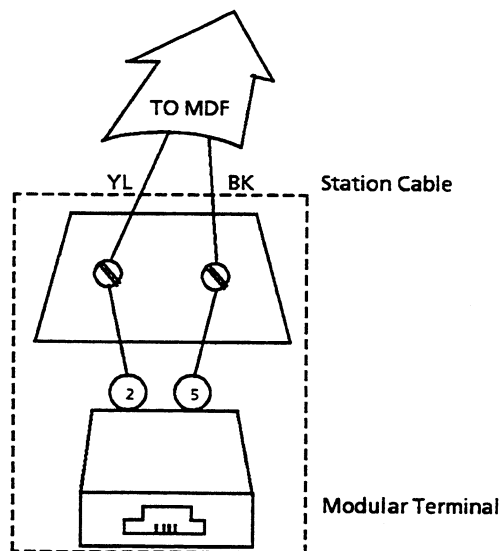

Figure 1-36 Modular Terminal for Connection of ETW Multiline Terminals and SLT Adaptor

6.2.1.2 Single Line Telephone Connection

DTMF or DP dialing and Single Line Telephones can be used to dial within the system. One-pair cabling is required, twisted-pair cabling is recommended. (Refer to Table 1-23 - Connection Information/Connection and Port Relationships for lead functions. Also refer to Figure 1-37 - Simplified Single Line Telephone Connection for station termination.)

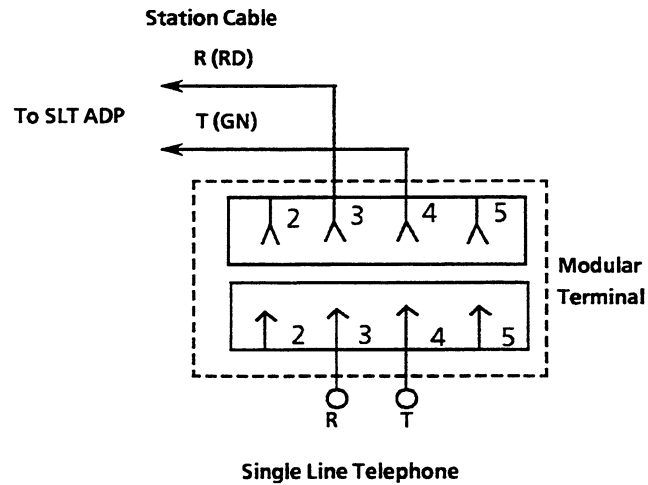

Figure 1-37 Simplified Single Line Telephone Connection

6.2.2 KSU Cable Routing

All cabling should exit from the right side of the KSU. The cable routing for the KSU is shown in Figure 1-38- KSU Cable Routing.

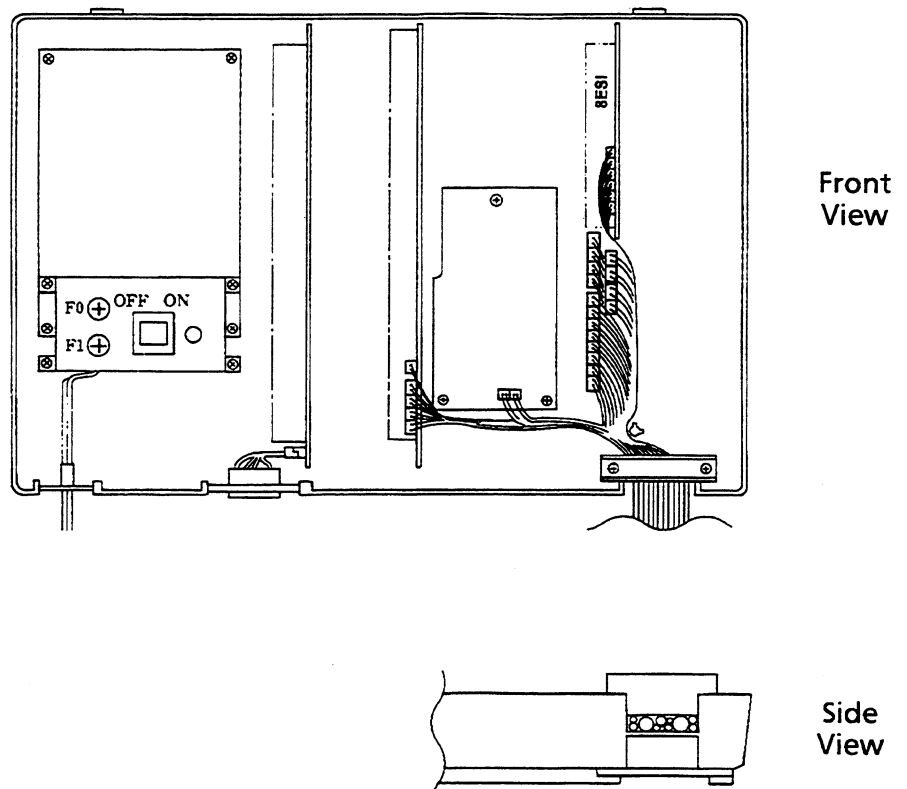

Figure 1-38 KSU Cable Routing

6.2.3 Outside Lines

The FCC authorized connector for the connection of CO lines is an RJ11X. The CO lines are connected in sequence within this termination block. Therefore, the lines must be arranged in the appearance order best suited to customer usage.

Loop start lines can be connected to this system. Use only twisted-pair wiring to crossconnect the lines from the RJ11 termination block to the system.

Do not use half-tapping or parallel connections on outside lines connected to the system. (Refer to Figure 1-39 - Connecting CO/PBX Lines.)

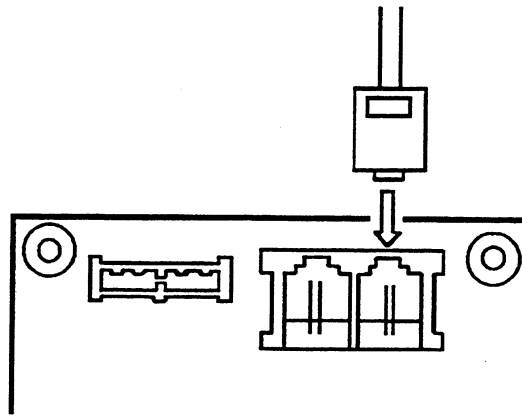

Figure 1-39 Connecting CO/PBX Lines

SECTION 7 TERMINAL INSTALLATIONS

7.1 General Information

The Electra Professional Level I system has five types of Digital Multiline Terminals and three types of Multiline Terminals and an SLT Adaptor, which allows connection of Single Line Telephones.

This section provides the instructions for wall mounting a Multiline Terminal and installing the plastic panels provided with the telephones.

7.2 Digital Multiline Terminals

This section describes different Electra Elite digital multiline terminals for all Electra Professional systems. Each terminal comes with a cable with an RJ11 connector at both ends with one end already connected to the LINE receptacle. A green number display card and an adapter to connect it to the terminal are also included. The Electra Professional telephones with displays also have softkeys.

7.2.1 DTU-8-() (BK)/(WH) TEL

This non-display digital multiline terminal has eight programmable line keys (each with a two-color LED), built-in speakerphone, headset jack, a Large LED to indicate incoming calls and messages, and compatibility with the ADA-U, APR-U, and HFU-U Units. Refer to Figure 1-40 - DTU-8-() (BK)/(WH) TEL.

A combined maximum of 15 Electra Professional and Electra Elite digital terminals can be installed in the Electra Professional Level I system.

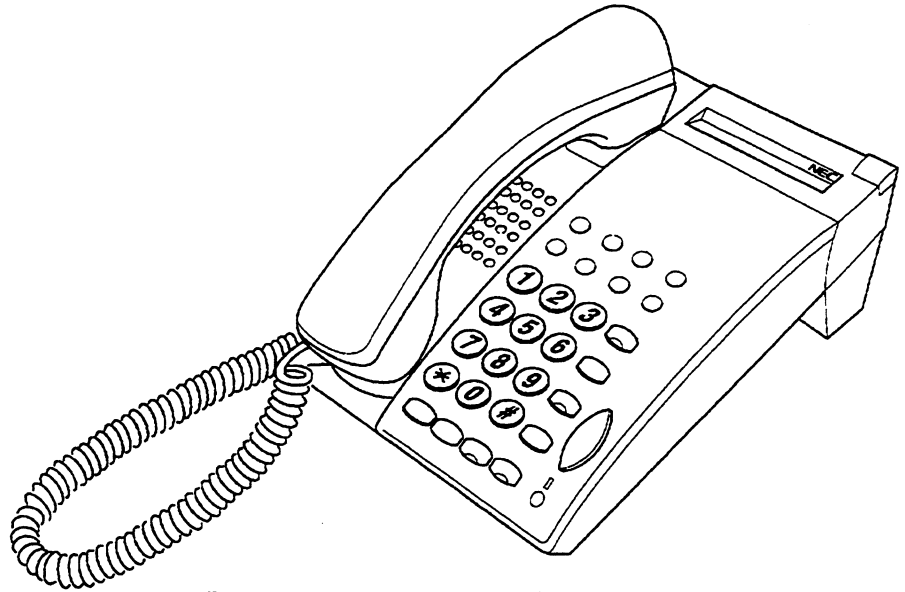

Figure 1-40 DTU-8-() (BK)/(WH) TEL

7.2.2 DTU-16-() (BK)/(WH) TEL

This non-display digital multiline terminal has 16 programmable line keys (each with a two-color LED), built-in speakerphone, a built-in headset jack, a Large LED to indicate incoming calls and messages, and compatibility with the ADA-U, APR-U, and HFU-U Units. Refer to Figure 1-41 - DTU-16-() (BK)/(WH) TEL.

A combined maximum of 16 Electra Professional and Electra Elite digital terminals can be installed in the Electra Professional Level I system.

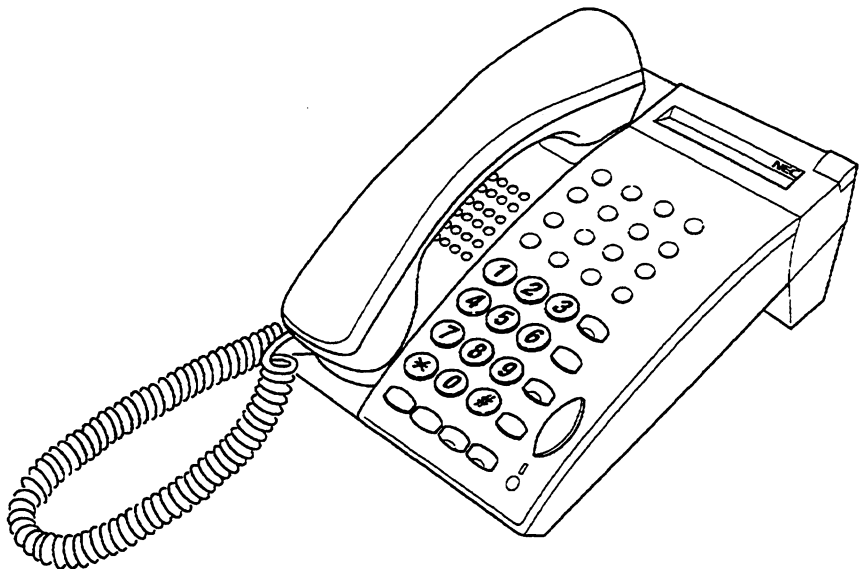

Figure 1-41 DTU-16-() (BK)/(WH) TEL

7.2.3 DTU-16D-() (BK)/(WH) TEL

This display digital multiline terminal has 16 programmable line keys (each with a two-color LED), built-in speakerphone, a built-in headset jack, a Large LED to indicate incoming calls and messages, and compatibility with the ADA-U, APR-U, and HFU-U Units. This terminal comes in black or white. Refer to Figure 1-42 - DTU-16D-() (BK)/(WH) TEL.

The adjustable LCD (Liquid Crystal Display) has 3,24-character lines.

Four softkeys are provided with the DTU-16D-(1) (BK)/(WH) TEL.

A combined maximum of 16 Electra Professional and Electra Elite digital terminals can be installed in the Electra Professional Level I system.



Figure 1-42 DTU-16D-() (BK)/(WH) TEL

7.2.4 DTU-32-() (BK)/(WH) TEL

This non-display digital multiline terminal has 32 programmable line keys (each with a two-color LED), built-in speakerphone, built-in headset jack, a Large LED to indicate incoming calls and messages, and compatibility with the ADA-U, APR-U, and HFU-U Units. Refer to Figure 1-43 - DTU-32-() (BK)/(WH) TEL.

A combined maximum of 16 Electra Professional and Electra Elite digital terminals can be installed in the Electra Professional Level I system.

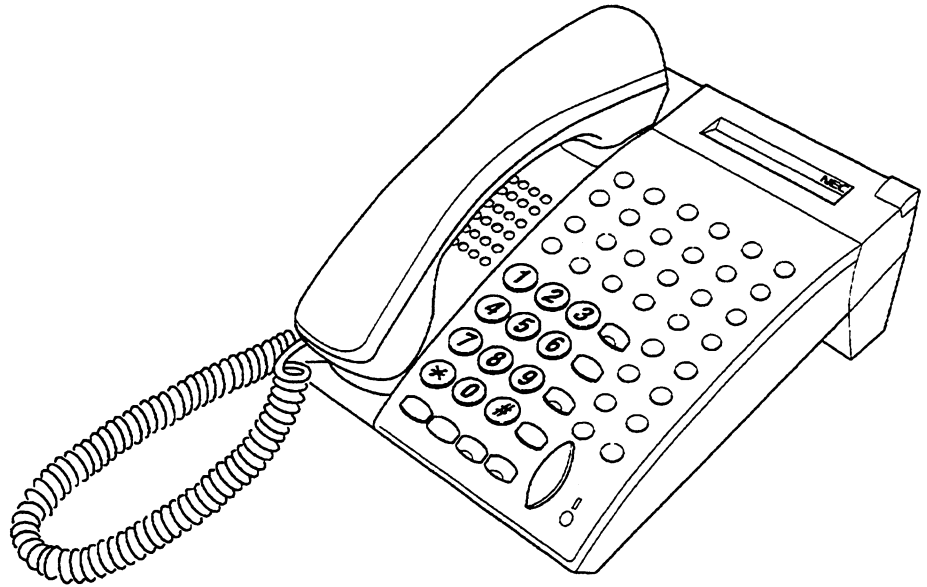

Figure 1-43 DTU-32-() (BK)/(WH) TEL

7.2.5 DTU-32D-() (BK)/(WH) TEL

This display digital multiline terminal has 32 programmable line keys (each with a two-color LED), built-in speakerphone, built-in headset jack, a Large LED to indicate incoming calls and messages, and compatibility with the ADA-U, APR-U, and HFU-U Units. This terminal comes in black or white. Refer to Figure 1-44 - DTU-32D-() (BK)/(WH) TEL.

The adjustable LCD (Liquid Crystal Display) has 24 characters and 3 lines.

Four softkeys are provided with the DTU-32D-2 (BK)/(WH) TEL.

A combined maximum of 16 Electra Professional and Electra Elite digital terminals can be installed in the Electra Professional Level I system.

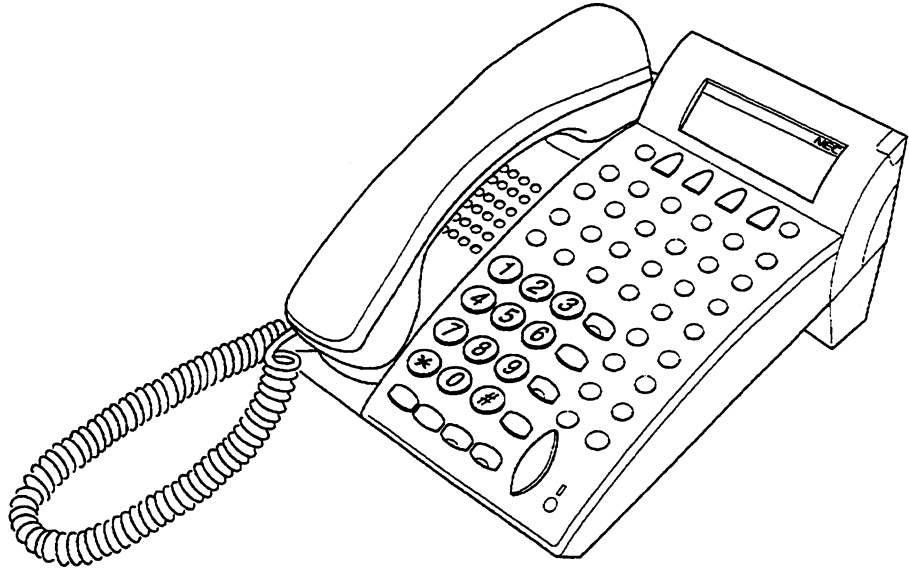

Figure 1-44 DTU-32D-() (BK)/(WH) TEL

7.2.6 Adjusting the LCD

The adjustable Liquid Crystal Display (LCD) comes equipped on some Electra Elite Multiline Terminals. Push upward or downward to adjust the LCD. Refer to Figure 1-45 - Adjusting the LCD.

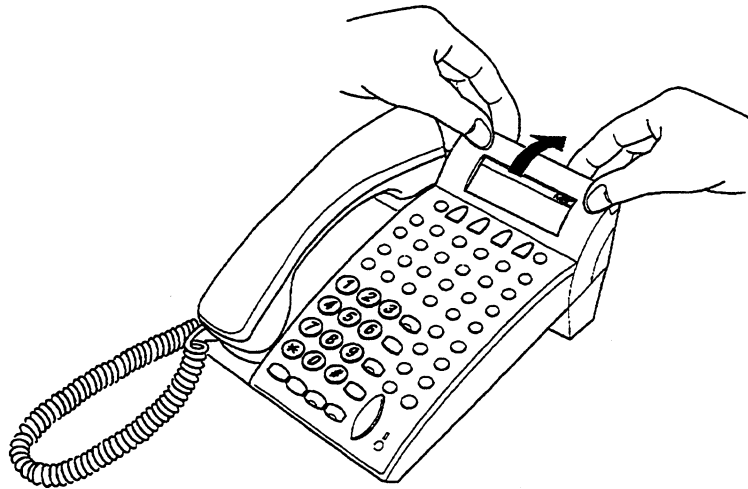

Figure 1-45 Adjusting the LCD

7.2.7 Line Card and Plastic Panel Installation

Line cards can be used to print the line key designations that are then placed on the Multiline Terminal providing a quick reference of key designations to the Multiline Terminal user. The Line Cards can be changed as necessary.

1. Place the Line Card over the keys on the Multiline Terminal.
2. Place the plastic panel over the keys on the Multiline Terminal and snap it into place. Refer to Figure 1-46 - Installing Line Card and Plastic Panel on a Multiline Terminal.

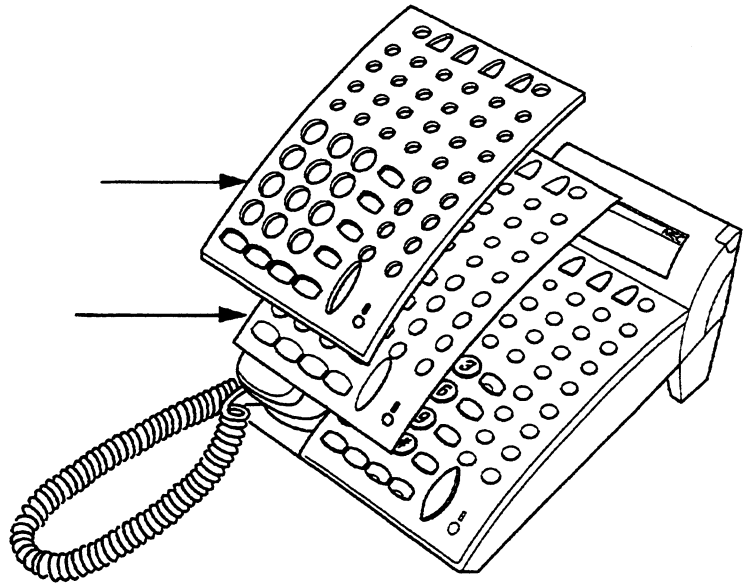

Figure 1-46 Installing Line Card and Plastic Panel on a Multiline Terminal

3. Press the top right side of the plastic panel toward the handset, and raise the panel to remove it. Refer to Figure 1-47 - Removing the Plastic Panel from the Multiline Terminal.
CAUTION: Pulling on the bottom to remove the plastic panel can damage the panel.

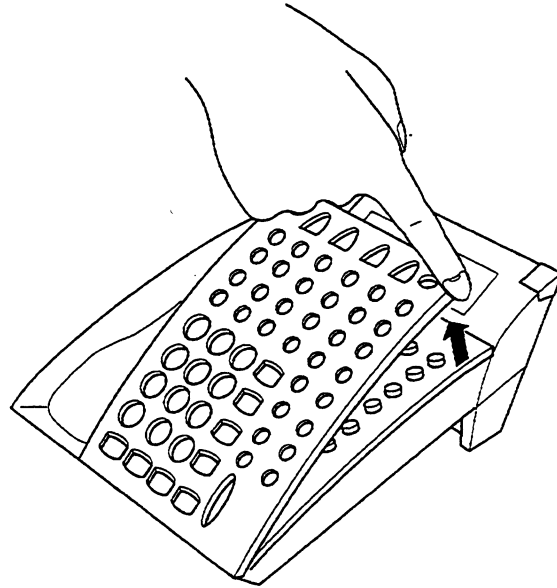

Figure 1-47 Removing the Plastic Panel from the Multiline Terminal

4. Insert the two bars at the bottom of the plastic panel all the way into the grooves on the Multiline Terminal, lower the plastic panel and press the top right and left ends to secure it to the terminal.

7.3 Electra Professional Multiline Terminals

7.3.1 ETW-8-1 (BK)/(SW) TEL

This Multiline Terminal is a fully modular instrument with eight flexible line keys (each with a two-color LED), eight function keys, a built-in speakerphone, an ADA interface, and a large LED to indicate incoming calls and messages. Refer to Figure 1-48 - ETW-8-1 (BK)/(SW) TEL Multiline Terminal.

A maximum of 15 ETW-8-1 (BK)/(SW) TELs can be installed in a system.

Note: ETW-8-1(BK)/(SW) TEL is not recommended for use as a programming position.



Figure 1-48 ETW-8-1 (BK)/(SW) TEL Multiline Terminal

7.3.2 ETW-16DC-1 (BK)/(SW) TEL

This Multiline Terminal is a fully modular instrument with 16 flexible line keys (each with a two-color LED), eight function keys, a 2-line, 16-character Liquid Crystal Display (LCD), and a large LED to indicate incoming calls and messages. Refer to Figure 1-49 - ETW-16DC-1 (BK)/(SW) TEL Multiline Terminal.

A maximum of 16 ETW-16DC-1 (BK)/(SW) TELs can be installed in a system.



Figure 1-49 ETW-16DC-1 (BK)/(SW) TEL Multiline Terminal

7.3.3 ETW-16DD-1 (BK)/(SW) TEL

This Multiline Terminal is a fully modular instrument with 16 flexible line keys (each with a two-color LED), eight function keys, 2-line, 16-character Liquid Crystal Display (LCD), 20 programmable One-Touch keys with BLFs, and a large LED to indicate incoming calls and messages. Refer to Figure 1-50 - ETW-16DD-1 (BK)/(SW) TEL Multiline Terminal.

A maximum of 16 ETW-16DD-1 (BK)/(SW) TELs can be installed in a system.



Figure 1-50 ETW-16DD-1 (BK)/(SW) TEL Multiline Terminal

7.3.4 Connecting a Multiline Terminal to the System

1. Plug a telephone cord into the modular jack on the bottom side of the Multiline Terminal. (Refer to Figure 1-51 - Connecting a Multiline Terminal to the System.)
2. Lead the cord out through the cord groove.

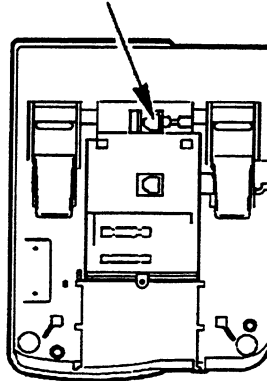

Figure 1-51 Connecting a Multiline Terminal to the System

7.3.5 Installing the Plastic Panel on a Multiline Terminal

1. Place the designation card over the keys on the Multiline Terminal. (Refer to Figure 1-52 - Installing the Designation Card, Plastic Panel, and Labels on a Multiline Terminal.)
2. Insert the top hooks of the clear plastic panel in the applicable holes on the Multiline Terminal, then place the bottom hooks in the Multiline Terminal. Snap the plastic panel into place to secure it. (Refer to Figure 1-52 - Installing the Designation Card, Plastic Panel, and Labels on a Multiline Terminal.)
3. Remove the station number label and place on the handset hook.
4. Remove the directory card from the sheet and put it on the directory tray. (Refer to Figure 1-52 - Installing the Designation Card, Plastic Panel, and Labels on a Multiline Terminal.)

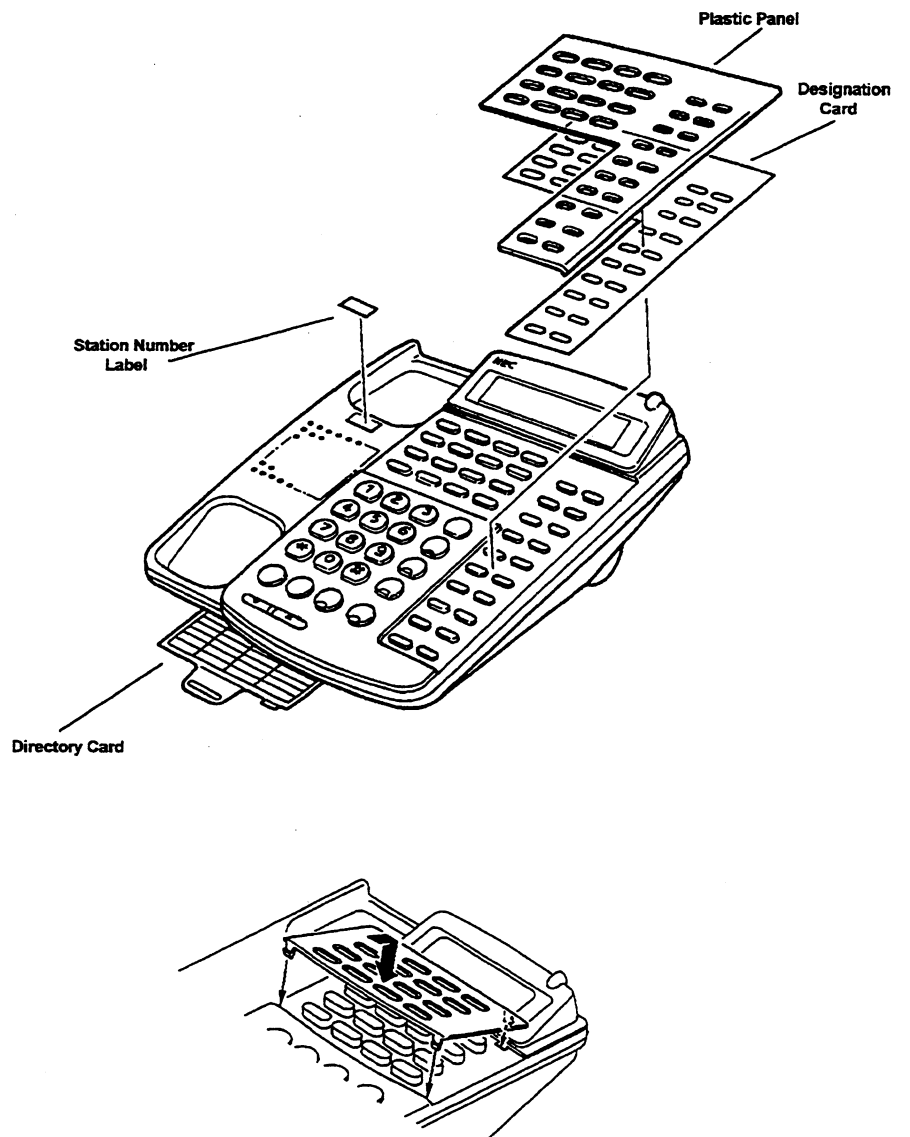

Figure 1-52 Installing the Designation Card, Plastic Panel, and Labels on a Multiline Terminal

7.3.6 Tilt Stand Adjustment

1. To unfold the legs on the tilt stand:
 - a. Turn the Multiline Terminal upside down.
 - b. Unfold the legs until they lock. (Refer to Figure 1-53 - Unfolding the Legs of the Tilt Stand.)

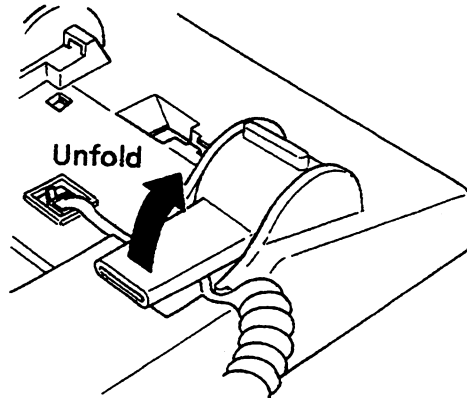

Figure 1-53 Unfolding the Legs of the Tilt Stand

2. To fold the legs on the tilt stand:
 - a. Turn the Multiline Terminal upside down.
 - b. Press the mold labeled *Push*.
 - c. Fold the legs toward the body of the telephone. (Refer to Figure 1-54 - Folding the Legs of the Tilt Stand.)

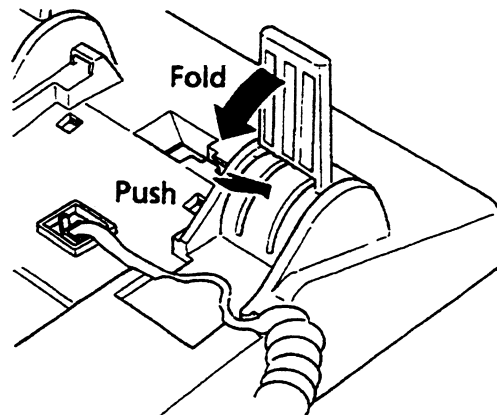

Figure 1-54 Folding the Legs of the Tilt Stand

7.4 SLT-F(1G)-() ADP

This Single Line Telephone Adaptor provides an interface for a Single Line Telephone or similar devices from an electronic station port KTU channel. This adaptor includes a built-in ringing signal generator (RSG).

7.4.1 Connection

One cable, with RJ11 connections at both ends, is provided with this unit. This cable is used to connect the adaptor to an ESI port. Another cable with RJ11 connectors is required to connect an SLT or similar devices. Refer to Figure 1-55 - SLT-F(1G)-() ADP.

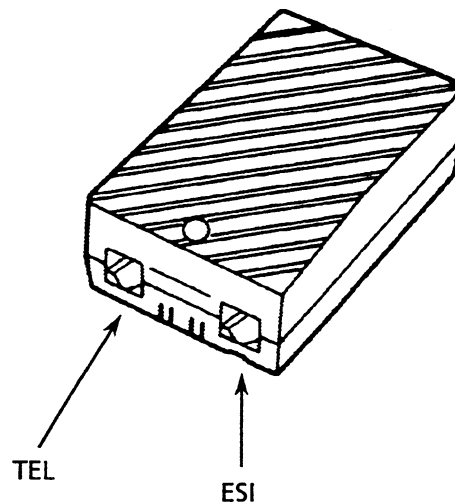

Figure 1-55 SLT-F(1G)-() ADP

The following diagram shows the connection from an ESI port to a Single Line Telephone using the SLT-F(1G)-() ADP. [Refer to Figure 1-56 - Connecting a Single Line Telephone Using the SLT-F(1G)-() ADP.]

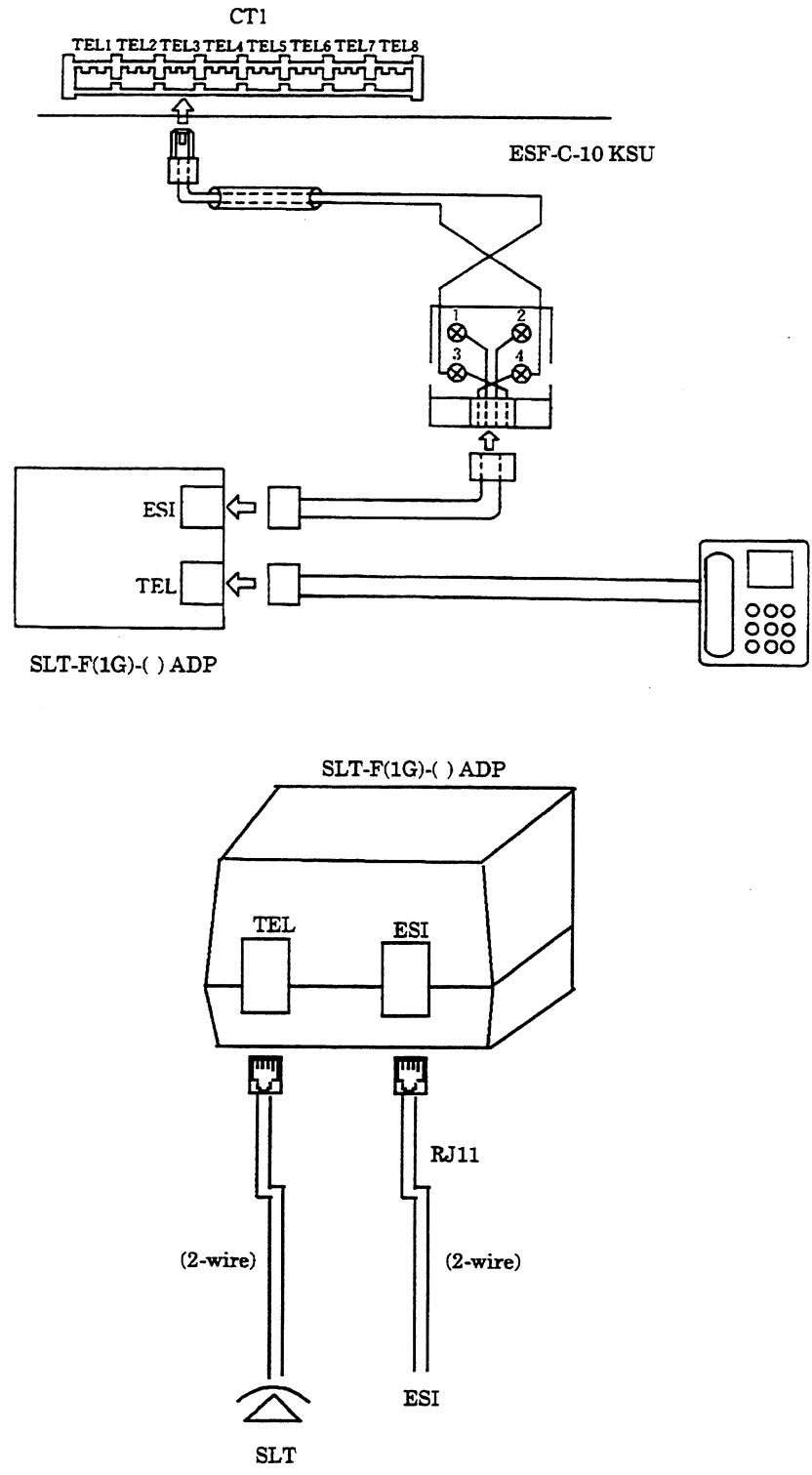

Figure 1-56 Connecting a Single Line Telephone Using the SLT-F(1G)-() ADP

7.4.2 Wall Mounting the SLT-F(1G)-() ADP

There are two ways to wall mount this adaptor.

1. Use the wall mount location on the rear with one screw.

- OR -

1. To open the unit, remove the two screws from the top of the SLT-F(1G)-() ADP. Refer to Figure 1-57 - Remove Screws from the Cover of the SLT-F(1G)-() ADP.

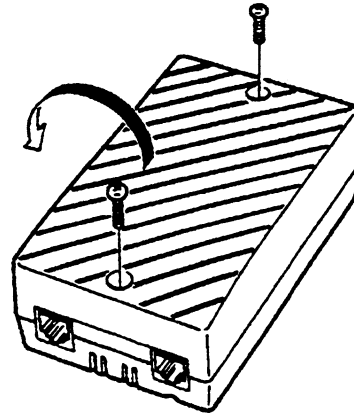

Figure 1-57 Remove Screws from the Cover of the SLT-F(1G)-() ADP

2. Use the two provided wood screws to attach the unit to the wall. Close the unit and secure with the two screws previously removed. Refer to Figure 1-58 - Attach SLT-F(1G)-() ADP to the Wall.

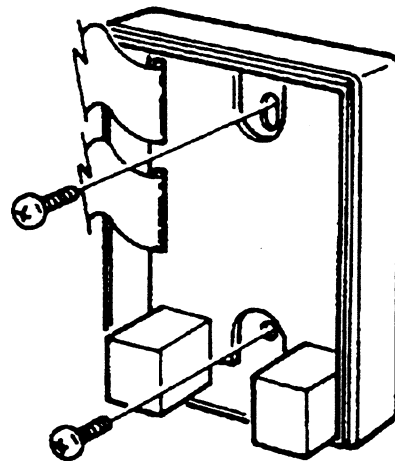

Figure 1-58 Attach SLT-F(1G)-() ADP to the Wall

7.5 Wall Mounting Units

7.5.1 General

The WMU-U (BK)/(SW) Unit is a universal Wall Mount Unit used to mount any Electra Elite Multiline Terminal.

The WMU-W (BK)/(SW) Unit is a universal Wall Mount Unit used to mount any Electra Professional Multiline Terminal.

7.5.2 Install the Electra Elite WMU-U Unit

1. Slide the hanger out of the slot. Place it back in its original position so that the hanger protrudes providing a rest for the handset. (This procedure applies when using either the base unit or the WMU-U Unit.) Refer to Figure 1-59 Position Handset Hanger for the steps to remove and remount the handset hanger.

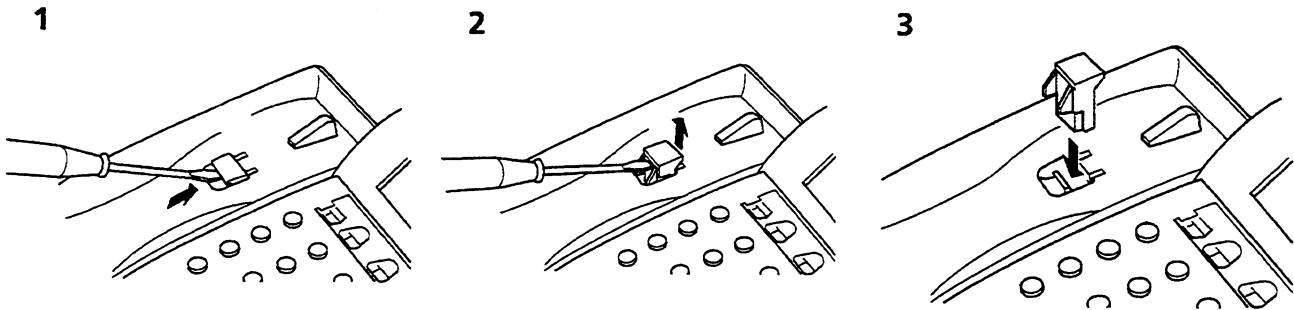

Figure 1-59 Position Handset Hanger

2. Remove the base unit by pressing the tabs on each side of the base plate and lifting upward. Refer to Figure 1-60 Remove the Base unit

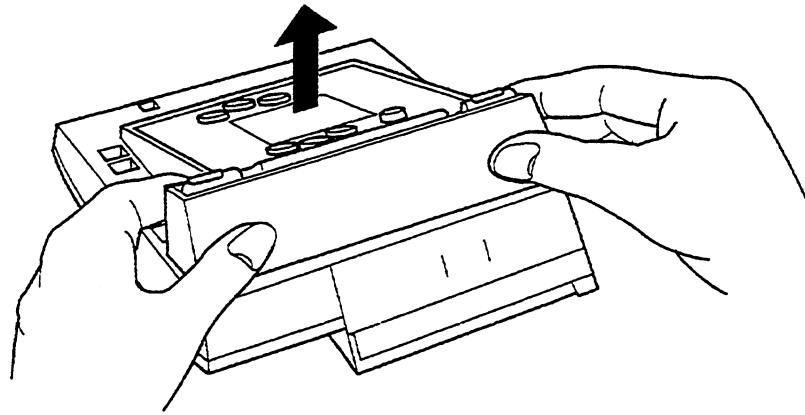

Figure 1-60 Remove the Base Unit

3. Use nippers to remove the shaded area in Figure 1-61 Remove the Knockout

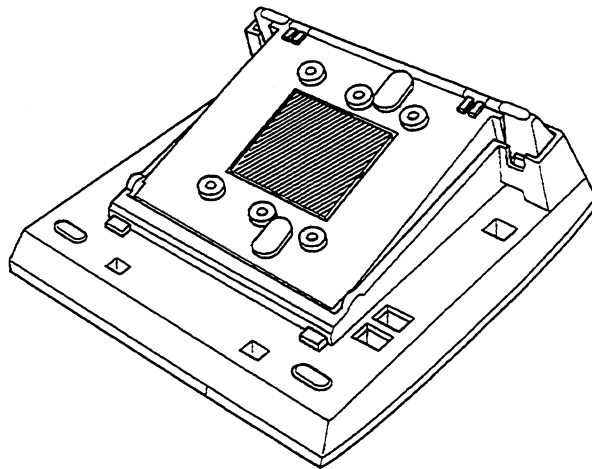

Figure 1-61 Remove the Knockout

4. Attach the base unit to the posts on the locally provided wall plate. Using locally provided screws, secure the base unit to the wall. Place the screws in the nodes provided on the base unit. (Place the wider end of the base unit down.) Attach the base unit to the wall plate as shown in Figure 1-62 Attach Base Unit to the Wall.

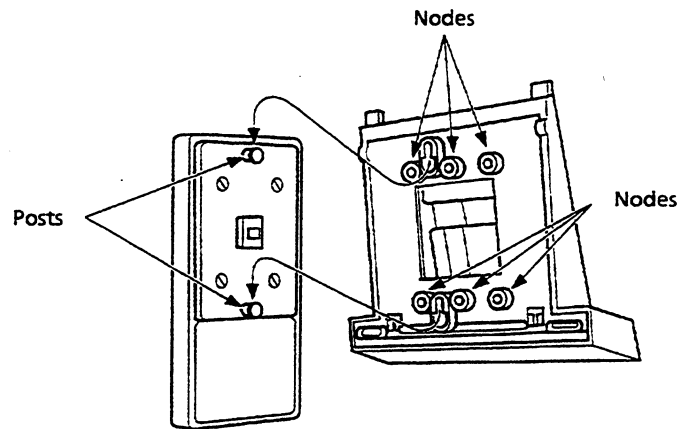

Figure 1-62 Attach Base Unit to the Wall

If using a modular jack instead of a wall plate, put the modular jack inside the base unit as shown in Figure 1-63 Wall Mount Using a Modular Jack. Use the locally provided screws to attach the base unit directly to the wall.

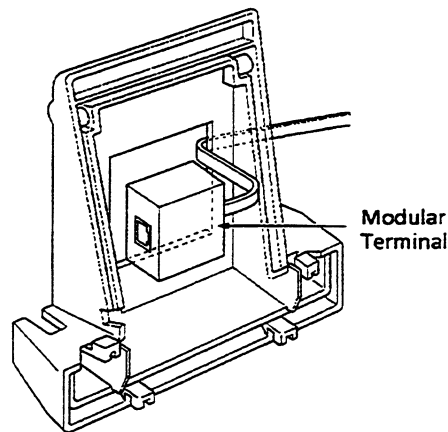

Figure 1-63 Wall Mount Using a Modular Jack

5. Plug the line cord in the jack on the wall plate, wrap the extra cord and secure it with a tie wrap, and lead the line cord out through the groove in the side of the base unit. Refer to Figure 1-64 Plug in the Line Cord Using a Wall Jack.

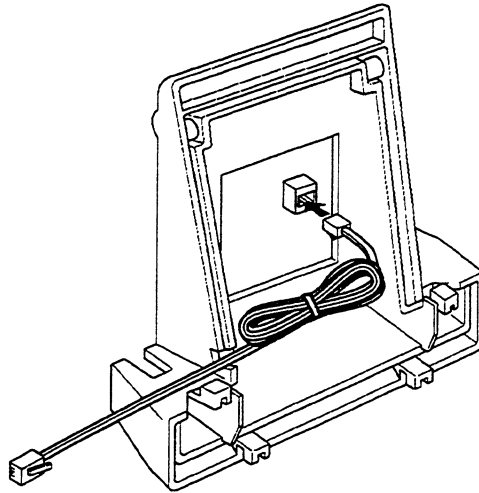

Figure 1-64 Plug in the Line Cord Using a Wall Jack

If using a modular jack instead of a wall plate, plug the line cord in the modular jack, wrap the extra cord and secure it with a tie wrap, and lead the line cord out through the groove in the side of the base unit. Refer to Figure 1-65 Plug in the line cord Using a Modular Jack.

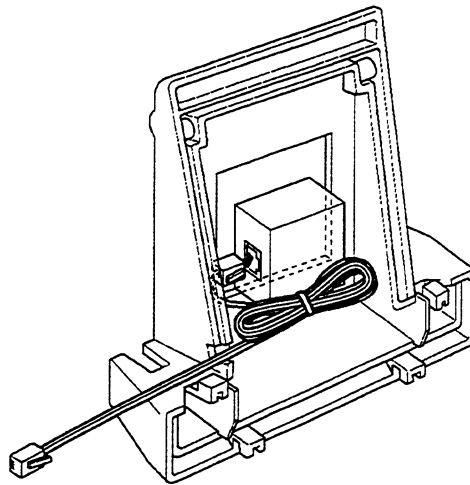

Figure 1-65 Plug in the Line Cord Using a Modular Jack

6. With the base unit attached to the wall, hook the two bottom tabs on the base unit in the tab slots on the Digital Multiline Terminal. Refer To Figure 1-66 Attach Bottom Tabs of the Digital Multiline Terminal to the Base Unit.

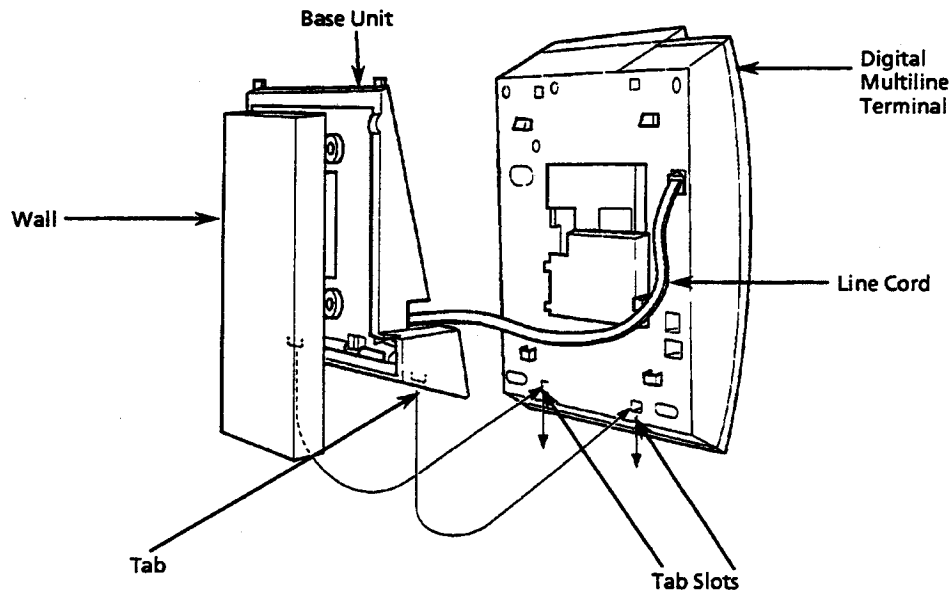

Figure 1-66 Attach Bottom Tabs of the Digital Multiline Terminal to the Base Unit

6. Push up on the terminal and lock the top tabs on the base unit in the tab slots on the Digital Multiline Terminal. Refer to Figure 1-67 Attach Top Tabs of the Digital Multiline Terminal to the Base Unit.

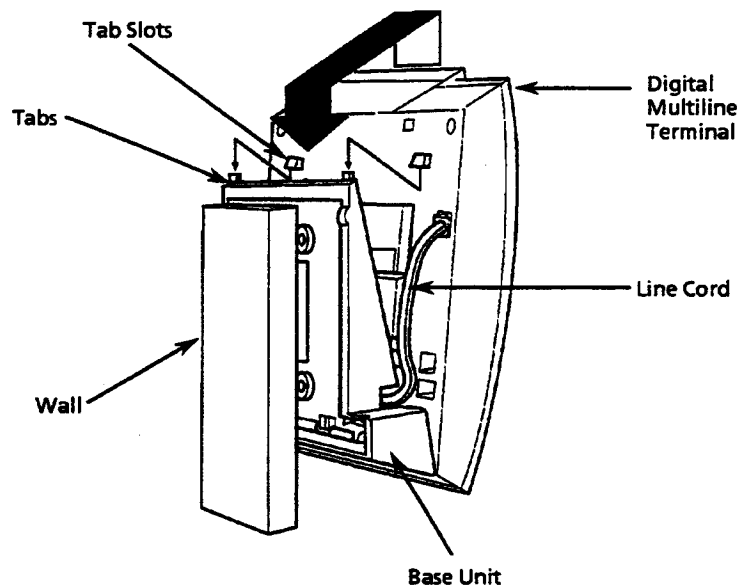

Figure 1-67 Attach Top Tabs of the Digital Multiline Terminal to the Base Unit

8. When properly installed, the wall mounted Digital Multiline Terminal looks similar to the one shown in Figure 1-68 Installed Wall Mount Unit.

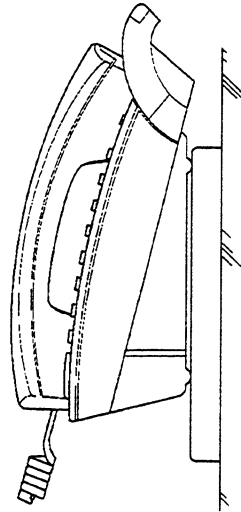

Figure 1-68 Installed Wall Mount Unit

7.5.3 Install the Electra Professional WMU-W Unit.

1. Remove the station number plate and designation strip.
2. To remove the hanger, slide it out. Mount it back in the original position with the projected side facing up. Refer to Figure 1-69 - Wall Mounting Preparation.

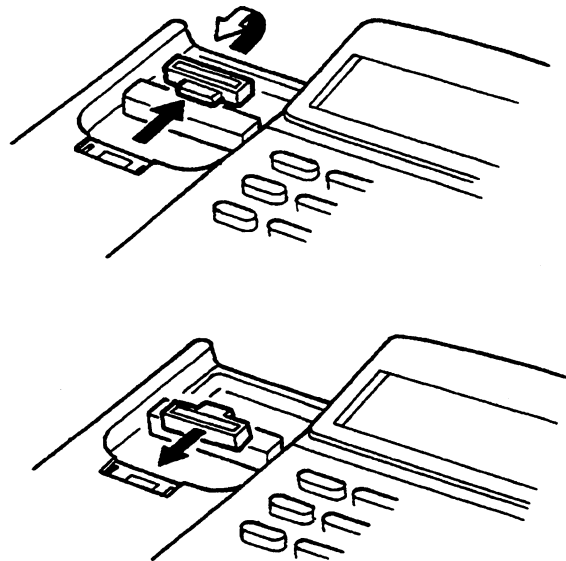

Figure 1-69 Wall Mounting Preparation

3. Reinstall the station number plate and designation strip.
4. Fasten the optional WMU-W (BK)/(SW) Unit to the wall. Refer to Figure 1-70 - Mount WMU-W (BK)/(SW) Unit to the Wall.

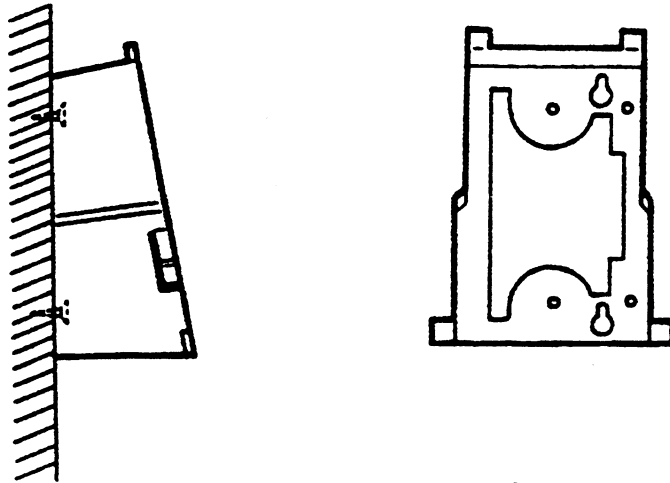

Figure 1-70 Mount WMU-W (BK)/(SW) Unit to the Wall

5. Mount the telephone onto the wall mounting unit by aligning the notches on the bottom of the Multiline Terminal with the rails on the wall mounting unit. Refer to Figure 1-71 - Mount Multiline Terminal to WMU-W (BK)/(SW) Unit.

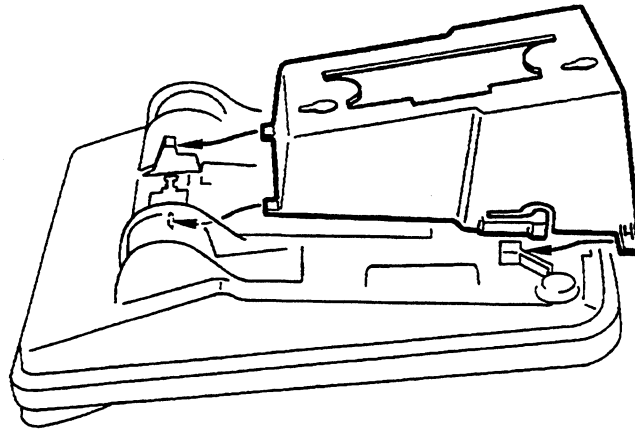

Figure 1-71 Mount Multiline Terminal to WMU-W (BK)/(SW) Unit

SECTION 8 ANCILLARY DEVICE CONNECTION

8.1 General Information

ADA-U Unit

This ancillary device adapter allows connection of a tape recorder to log/record telephone calls to Electra Elite Multiline Terminals. Dedicated input connectors are also provided for a recording tone to inform parties that a call is being recorded.

A maximum of 16 ADA-U units can be installed in the Electra Professional Level 1 system, one per Multiline Terminal.

ADA(1)-W (BK)/(SW) Unit

This Ancillary Device Adapter Unit provides the Multiline Terminal with connection for an amplified handset, a headset, external speakerphone, or other ancillary devices. An ADA(1)-W (BK)/(SW) Unit can be installed in any Electra Professional Multiline Terminal.

A maximum of 16 ADA(1)-W (BK)/(SW) Units can be installed in a system, one per Multiline Terminal.

ADA(2)-W (BK)/(SW) Unit

This Ancillary Device Adapter Unit provides the Multiline Terminal with a Single Line Telephone interface. An ADA(2)-W (BK)/(SW) Unit can be installed in any Electra Professional Multiline Terminal and allows connection of a Single Line Telephone, cordless telephone, fax, modem, or an answering machine. The maximum distance between this unit and the equipment is 10 feet, using 24 AWG. An AC/DC adapter is required for power supply to the ADA(2)-W (BK)/(SW) Unit. This unit has a built-in RSG; hookflash detection, Message Wait, and disconnect signal are not supported.

A maximum of 16 ADA(2)-W (BK)/(SW) Units can be installed in a system, one per Multiline Terminal.

8.2 Install the Electra Elite ADA-U Unit

Install the Electra Elite Digital Multiline Terminals using the *green/red* pair at the wall jack instead of the yellow/black pair used with the Electra Professional Multiline Terminals.

When installing an ADA-U Unit, connect the cable to the ADA-U Unit, set the dip switches, and then install the ADA-U Unit on the terminal. The ADA-U Unit **does not** require an AC Adapter.

8.2.1 Install an ADA-U Unit on a Digital Multiline Terminal

1. Unplug the telephone cord from the terminal.
2. Press both the left and right ends of the tilt panel on the back of the terminal and remove it. Refer to Figure 1-72 Remove the Tilt Panel on the Digital Multiline Terminal

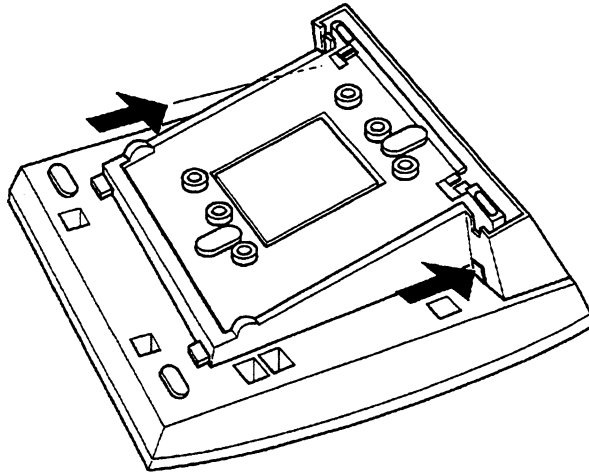

Figure 1-72 Remove the Tilt Panel on the Digital Multiline Terminal

3. Unlatch the cover by pressing the areas indicated in Figure 1-73 Unlatch the Cover on the Digital Multiline Terminal. Using a straight blade screwdriver, press the blade between the cover and the base to release the tabs.

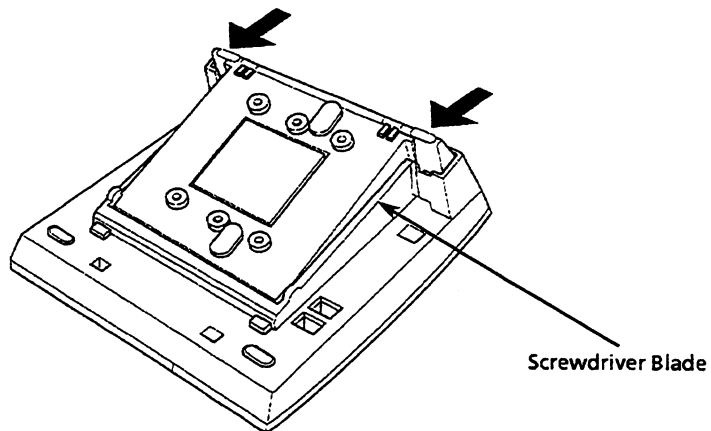

Figure 1-73 Unlatch the Cover on the Digital Multiline Terminal

4. Open the cover to allow access to the ADA receptacle. Refer to Figure 1-74
Open the Cover on the Digital Multiline Terminal.

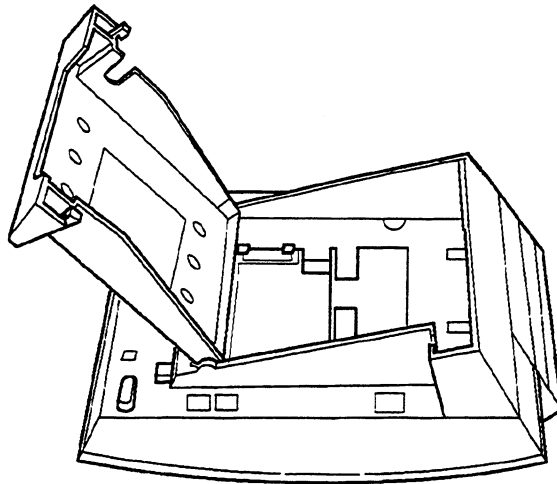

Figure 1-74 Open the Cover on the Digital Multiline Terminal

5. Plug the ADA-U Unit connector in the receptacle connector on the back of the terminal (Connector in the diagram). Snap the ADA-U Unit between Hooks on the diagram to secure it. Refer to Figure 1-75 Attach the ADA-U Unit to the Digital Multiline Terminal.

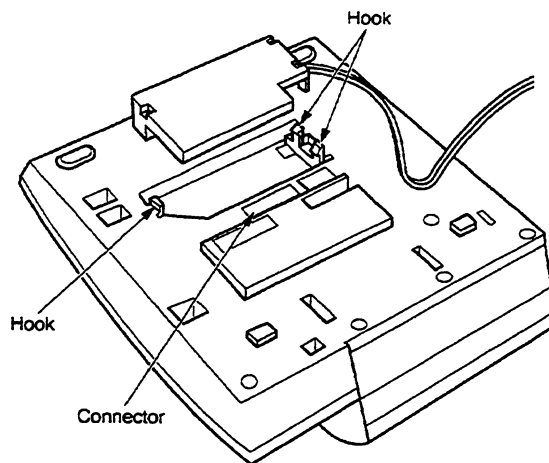

Figure 1-75 Attach the ADA-U Unit to the Digital Multiline Terminal

6. Lead the Telephone cord out through the groove on the tilt panel. Plug in the telephone cord. Refer to Figure 1-76 Lead the Telephone Cord out from the ADA-U Unit.

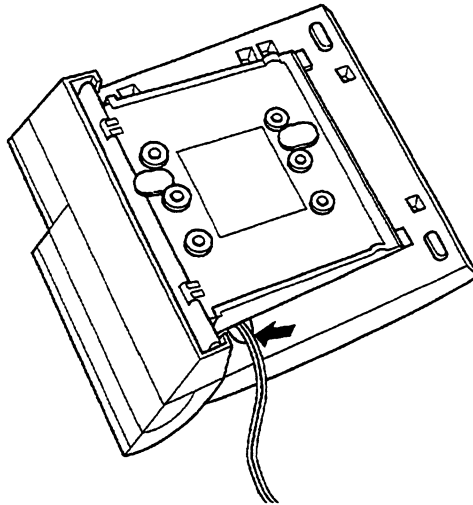

Figure 1-76 Lead the Telephone Cord out from the ADA-U Unit

8.2.2 Connecting Cables to the ADA-U Unit

Cable terminal connectors are located on the right side of the ADA-U Unit. Cables should be connected on this unit before installing the unit on the Digital Multiline Terminal. Refer to Figure 1-77 ADA-U Unit

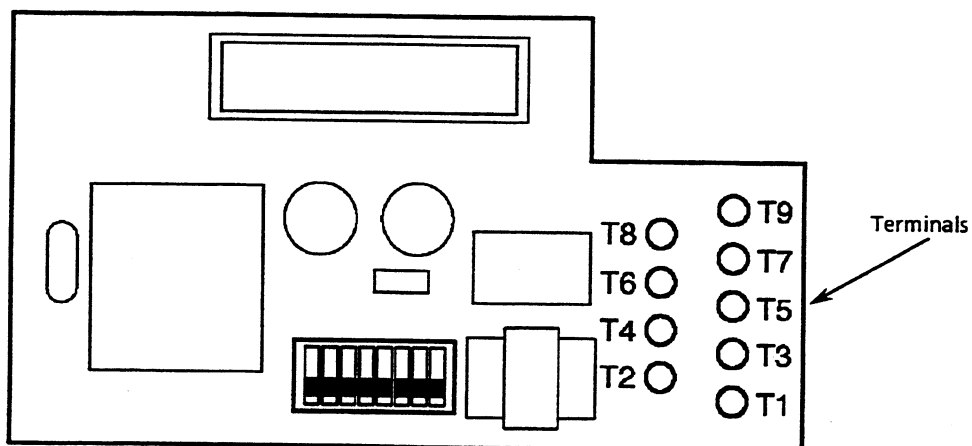

Figure 1-77 ADA-U Unit

1. Cut off the plug on one end of the cable.
2. Locate the adapter terminals on the right side of the unit shown in Figure 1-77 ADA-Unit.
3. Remove the cap on the adapter terminal to expose the metal receptacle. Push the cable in the applicable receptacle and replace the cap. Be sure to line up the slot on the cap with the slot on the metal receptacle to ensure proper contact. Refer to Figure 1-78 Attach Cables to the ADA-U Unit.

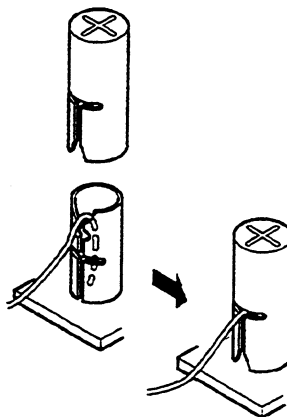

Figure 1-78 Attach Cables to the ADA-U Unit

4. Insulate the end of the cable that needs to be shielded with insulating tape.
- Table 1-24 ADA-U Cable Connections provides a list of cable connections to ADA-U ADP terminals and describes the specifications for the terminals.

Table 1-24 ADA-U Cable Connections

Terminal Number	Cables to Connect	Terminal Specifications
T1	Connect to T3 and T4.	Input Terminal: Terminal is enabled only when DIP switches 3 and 4 are OFF.
T2	T1 and T2 are input from a recording input generator. They are input-only and provide an audio path to the recording device when connected to T3 and T4.)	If switches 3 and 4 are ON, a humming sound may be recorded due to impedance mismatch. Input Impedance: 100K Ω Input Level: -15 dB ~ 40 dB (approximately)
T3	Connect the audio recording cable (2-way path).	Input/Output Terminal: To switch between line jack and the mic jack on the recorder, place impedance DIP switches 5 and 6 ON. Line jacks or other similar (600 Ω) devices: Input/Output Level: -15 dB ~ 40 dB (approximately)
T4	Connect the shielded end of the audio recording cable (2-way path).	Mic jacks or other similar low impedance devices: Input/Adapter Level: -40 dB ~ 60 dB (approximately)
T5	Connect the bare end of the control cable.	When a Digital Multiline Terminal is idle, this contact is open. When the terminal goes off-hook (using the handset, headset, or built-in speakerphone), this contact is closed. With the open contact, use both T5 and T6.
T6	Connect the shielded end of the control cable.	This provides common connection for control cable.
T7	Connect the bare end of the control cable.	When the Digital Multiline Terminal is idle, this contact is closed. When the terminal is busy (using the handset, headset, or built-in speakerphone), this contact is open. With the closed contact, use both T6 and T7.
T8	Connect to Off-Hook Control Lead A	A short between T8 and T9 causes the Digital Multiline Terminal to go off-hook and send audio to T3 and T4.
T9	Connect to Off-Hook Control Lead B	

Notes:

- * When the built-in microphone is used to record, a low recording level may occur for the transmit part of the conversation.
- * When recording in the handsfree (half-duplex) mode using the built-in speakerphone, the record notice tone may not be audible to the far-end party and/or speech may be interrupted or distorted when the tone is generated.
- * The transmit recording level is lower than the receiving voice level for intercom calls. The transmit recording levels for CO calls are matched.
- * If the record tone generator is separate from the recorder, a separate pair of cables is required. For this configuration, connect the record notice tone cables to input terminals T1 and T2 on the ADA-U. (T3 and T4 are used as the tape recorder input.)
- * If a remote control terminal is provided on a recorder and a control cable is used, the record start/stop control is provided by connecting the terminal to T5 (or T7) and T6 on the ADA-U. (Connecting to T5 or T7 is determined by the specifications of the recorder.)
- * If a Beep Tone is provided from the recording equipment, the Beep Tone should be input using T3 and T4 on ADA-U ADP. (Do not use T1 and T2 to input Beep Tone.)
- * Single Line Telephones connected to an APR-U Unit cannot be used to record conversations via the ADA-U Unit.

8.2.3 Switch Settings on the ADA-U Unit

The DIP switch, located at the bottom center of the ADA-U Unit, allows a technician to configure the board to specific settings. Figure 1-79 ADA-U Unit Switch Settings shows the default settings.

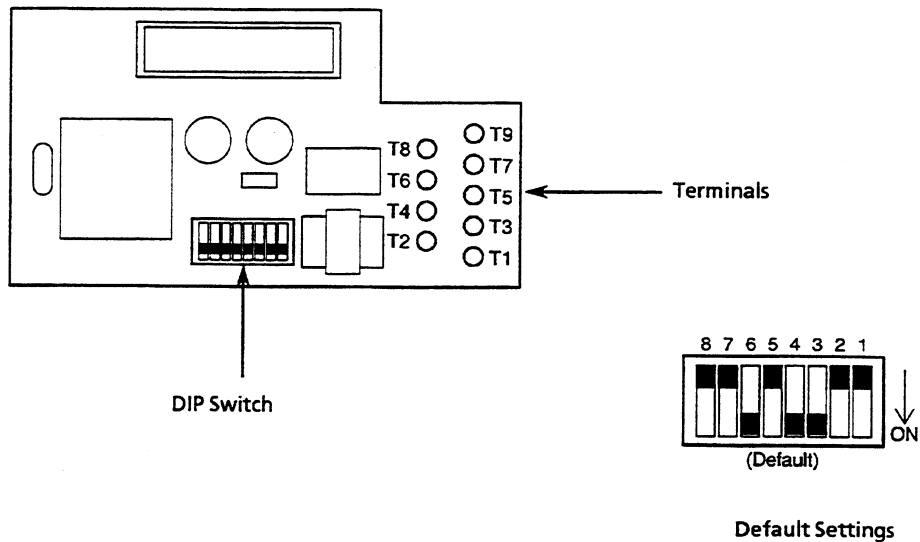

Figure 1-79 ADA-U Unit Switch Settings

The following switch settings should be made on the ADA-U Unit to enable or disable the record start notice tone. Switch settings should be made before installing the ADA-U Unit in the Digital Multiline Terminal. Refer to Table 1-25 ADA-U Unit Switch Settings.

Table 1-25 ADA-U Unit Switch Settings

Switch	Setting		Description
SW1-1	ON		Enables the relay control at T5, T6 or T6, T7.
SW1-2	OFF		N/A
SW1-3 and SW1-4	SW1-3 ON	SW1-4 ON	Beep Tone provided by the recording device, connected by T3 and T4. (Do not connect T1 and T2)
	SW1-3 OFF	SW1-4 OFF	Beep Tone provided by an external devices, connected by T1 and T2
SW1-5 and SW1-6	SW1-5 ON	SW1-6 ON	Input impedance for T5 and T6 are set to 600 Ω .
	SW1-5 OFF	SW1-6 OFF	Input impedance for T5 and T6 are set to 30 Ω .
SW1-7	ON		Enables the record tone input
SW1-8	OFF		N/A

Note: Do not connect T1 and T2 when switches 3 and 4 are ON.

8.3 Install the Ancillary Device Adapter Unit [ADA(1)-W (BK)/(SW) or ADA(2)-W (BK)/(SW)] in the Multiline Terminal

The ADA(1)-W (BK)/(SW) Unit or ADA(2)-W (BK)/(SW) Unit can be connected to any Multiline Terminal in the system.

1. Unplug the line and handset cords.
2. Turn the Multiline Terminal upside down and place it on a dry surface.
3. Remove the knockout (second from the top) on the bottom of the Multiline Terminal. Refer to Figure 1-80 - Remove the Knockouts to Install ADA(1)-W (BK)/(SW) Unit or ADA(2)-W (BK)/(SW) Unit.

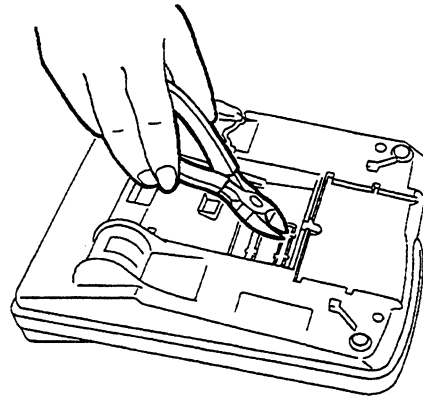

Figure 1-80 Remove the Knockouts to Install ADA(1)-W (BK)/(SW) Unit or ADA(2)-W (BK)/(SW) Unit

4. Plug the CN1 connector from the ADA(1)-W (BK)/(SW) Unit or ADA(2)-W (BK)/(SW) Unit, in the CN4 jack on the Main Board. Refer to Figure 1-81 - ADA(1)-W (BK)/(SW) Unit or ADA(2)-W (BK)/(SW) Unit Installation and Table 1-26 - ADA(1)-W (BK)/(SW) Unit or ADA(2)-W (BK)/(SW) Unit Cable Connection.
5. Mount the ADA(1)-W (BK)/(SW) Unit or ADA(2)-W (BK)/(SW) Unit into the Multiline Terminal using the screw provided (component side down). Refer to Figure 1-81 - ADA(1)-W (BK)/(SW) Unit or ADA(2)-W (BK)/(SW) Unit Installation.
6. Connect the external device (e.g., external speakerphone, fax, or answering machine) using the information provided in the applicable Engineering Technical Information bulletin (ETI).

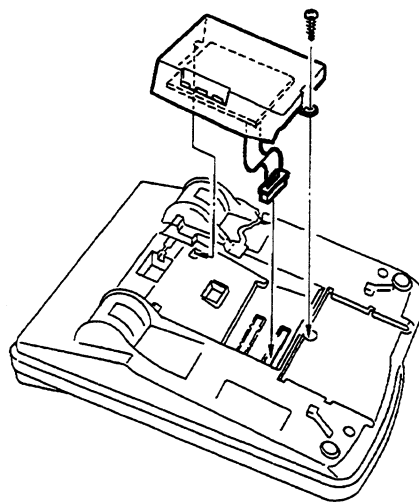

Figure 1-81 ADA(1)-W (BK)/(SW) Unit or ADA(2)-W (BK)/(SW) Unit Installation

Table 1-26 ADA(1)-W (BK)/(SW) Unit or ADA(2)-W (BK)/(SW) Unit Cable Connection

ADA(1)-W (BK)/(SW) Unit or ADA(2)-W (BK)/(SW) Unit	
From	To
CN1	CN4

- 7a. For ADA(2)-W (BK)/(SW) Unit only:
Plug the AC/DC adaptor in the jack located on the side of the ADA(2)-W (BK)/(SW) Unit.
- 7b. Plug in the handset and line cords.
8. Test the operation of the Multiline Terminal, and then test the operation of the external device.

8.4 Install the APR-U Unit

The Analog Port Adapter with Ringing provides an interface to install Single Line Telephones, modems, and NEC VoicePoint/VoicePoint Plus Conferencing units. The APR-U Unit also detects incoming ringing signals. By providing ring detection, the user can install a personal fax machine or an answering machine for convenience. Two user-adjustable switches are provided on the adapter; SW3 allows for 600 ohms or a complex impedance interface to devices such as a modem or Single Line Telephone, and SW1 is set to position 2 (the Electra Professional System does not support the B2 channel). The APR-U **requires** an AC Adapter, that is ordered separately. If an APR-U and HFU-U are both installed, only one AC Adapter is required.

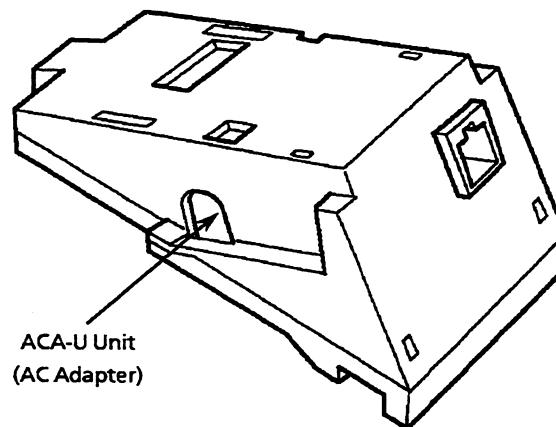
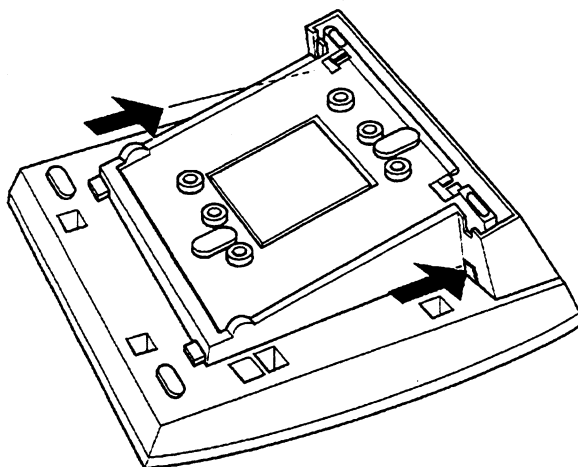

Figure 1-82 APR-U Unit

8.4.1 Install an APR-U Unit on a Digital Multiline Terminal

1. Unplug the telephone cord from the terminal
2. On the back of the terminal, press the areas indicated in the diagram to raise the inner area of the tilt panel.

**Figure 1-83 Raise the Tilt Panel**

3. Unlatch the cover by pressing the areas indicated by arrows in Figure 1-84. Unlatch the Cover on the Digital Multiline Terminal. Press a straight-blade screwdriver blade between the cover and the base to release the tabs. When both tabs are released, lift the cover.

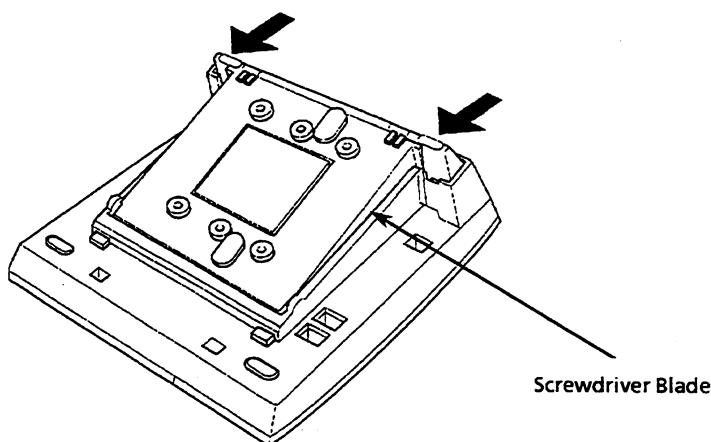
**Figure 1-84 Unlatch the Cover on the Digital Multiline Terminal**

4. Plug the receptacle connector on the unit in the receptacle connector inside the tilt panel on the terminal. Refer to Figure 1-85 Attach the Unit to the Digital Multiline Terminal.

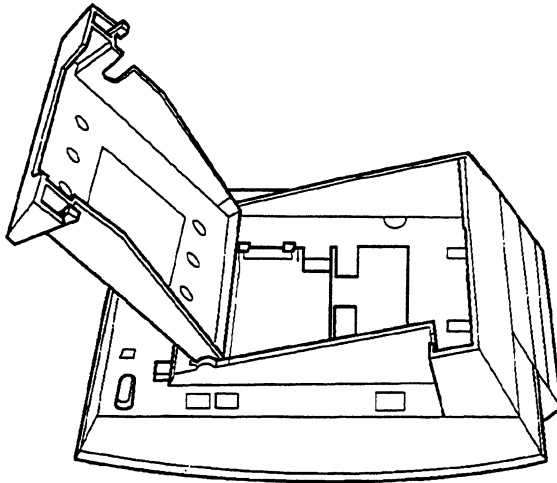

Figure 1-85 Attach the Unit to the Digital Multiline Terminal

5. Plug the cord of the ACA-U Unit in the jack on the APR-U Unit. The ACA-U Unit is a separate unit that can be purchased from NEC. Lead the AC Adapter cord out through the groove in the base as shown in Figure 1-86 Lead the AC Adapter Cord out from the Unit.

When connecting the AC Adapter (ACA-U Unit), connect it to the device in the left side of the adapter bay to allow the ACA-U Unit to supply power to all devices installed in the adapter bay.

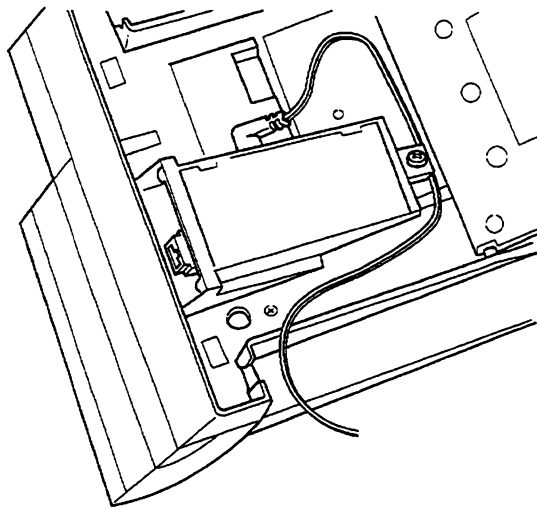

Figure 1-86 Lead the AC Adapter Cord out from the Unit

6. Close the tilt panel cover, lead the AC Adapter cord out through the hole and snap the cover in place.

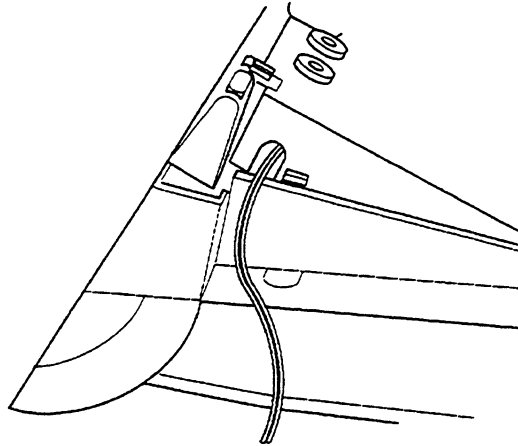

Figure 1-87 Close the Tilt Panel Cover

7. Plug in the power cord on the AC Adapter and the telephone cord in the jack.
8. Install the ferrite core one inch from the Digital Multiline Terminal.

Take the cord through the ferrite core and then make a loop back to the starting end and come through the ferrite core again to lead the cord out when using an APR-U Unit.



Figure 1-88 Ferrite Core Installation

8.4.2 Switch Settings

There are two switches on the APR-U Unit.

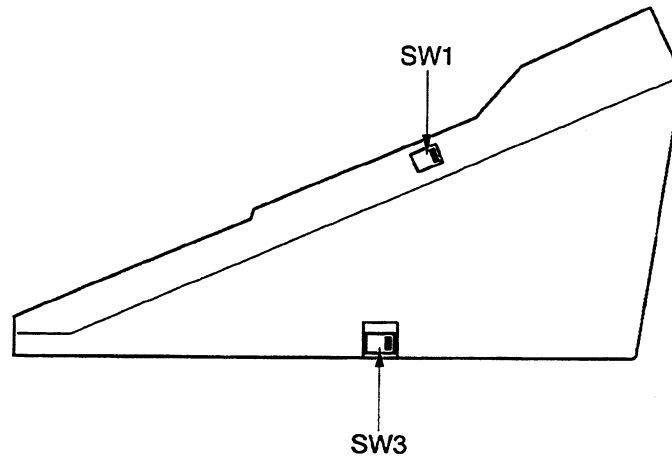

Figure 1-89 APR-U Unit Switches

Table 1-27 lists the switch settings for SW1 and SW3.

Table 1-27 APR-U Unit Switch Settings for SW1 and SW3

Switch	Description
SW1-1	A Single Line Telephone and Digital Multiline Terminal are used simultaneously. The Digital Multiline Terminal uses the B1 channel and the APR-U Unit would use the B2 channel if it were supported.
SW1-2	A Single Line Telephone and Digital Multiline Terminal are used alternately. The Digital Multiline Terminal and the APR-U Unit share the B1 channel. Position 2 must be selected because the Electra Professional system does not now support the B2 channel.
SW3-1	Sets impedance to 600 Ω for devices such as modems or facsimile machines
SW3-2	Used for complex impedance devices such as Single Line Telephones

8.5 Install the HFU-U Unit

The Handsfree Unit enhances small office teleconferencing by improving the sound quality of speakerphone calls using an external microphone. This unit is useful in a working environment where handsfree calling is a necessity. To provide maximum performance, two user-adjustable switches are available that allow the speaker phone to be configured for the customer environment (quiet room, noisy business environment, or a room with an acoustic echo).

Note: This unit provides an echo canceling circuit. However, it is primarily for a typical small office environment and not for conference rooms. Performance should not be compared to commercial audio conference units. Calls may not be recorded when using the HFU-U.

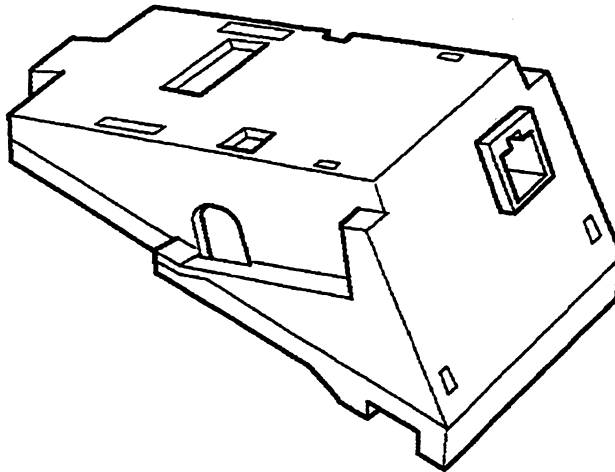
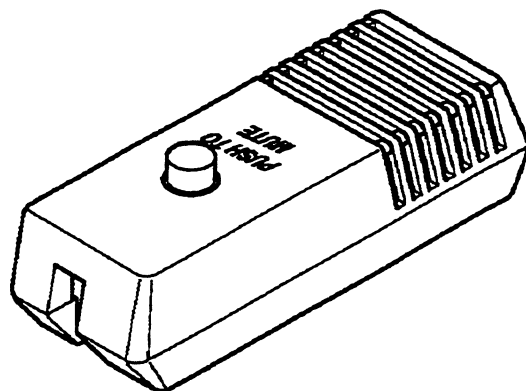

Figure 1-90 HFU-U Unit

8.5.1 Installing an HFU-U Unit on a Digital Multiline Terminal

An external microphone can be installed on the HFU-U Unit. These instructions apply to the external microphone included with the HFU-U Unit. This microphone has a push-to-mute button.



Minimum 2
Feet from
Multiline
Terminal

Figure 1-91 Microphone with Mute

1. Plug the microphone cord in the jack on the HFU-U Unit as shown in Figure 1-92 Attach Microphone to Digital Multiline Terminal.

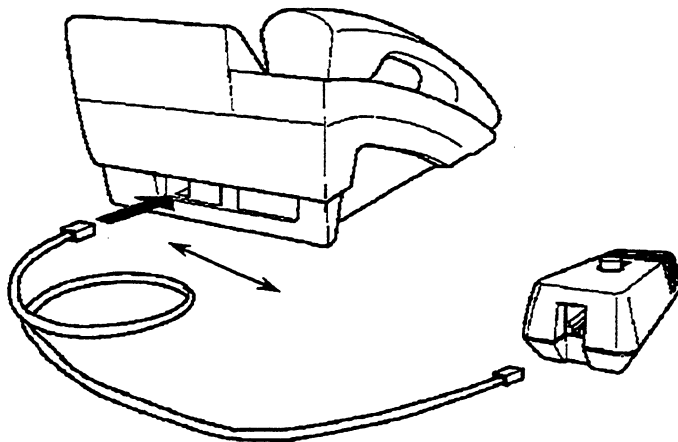

Minimum 2
Feet from
Multiline
Terminal

Figure 1-92 Attach Microphone to Digital Multiline Terminal

2. Set the switches on the HFU-U Unit as indicated in Table 1-28 HFU-U Unit Switch Settings.

Table 1-28 HFU-U Unit Switch Settings

Switch	Position	Switch	Position	Setting
SW1	2	SW2	2	Full Duplex
SW1	1	SW2	2	Half Duplex 6 dB Attenuation
SW1	2	SW2	1	Half Duplex 12 dB Attenuation
SW1	1	SW2	1	Half Duplex 18 dB Attenuation

SECTION 9 OPTIONAL EQUIPMENT CONNECTION

9.1 General Information

The system can support the following:

- External MOH/BGM
- Two Doorphones
- External Ringer
- External Night Chime
- External Paging

9.2 Music On Hold/Background Music

A locally provided external music source can be connected to provide Music On Hold for held calls and Background Music for external paging and station BGM.

Music source input is made using the quick connection jack MOH/BGM located on the main board. For music source input level and impedance, refer to Section 2.12.1 - Music On Hold (MOH)/Background Music (BGM) in this chapter.

Note: In compliance with FCC Part 15 regulations, the following procedure must be implemented when an MOH/BGM source is connected to this system.

To install:

1. Connect the Music On Hold source to the YL/OR pair on the MDF Cable assembly.
2. Shielded cabling should be used from the MOH source to the MDF cable. The shield on the MOH cable should also be grounded. Refer to Figure 1-93 - MOH/BGM Cable Shield Ground Exposed.

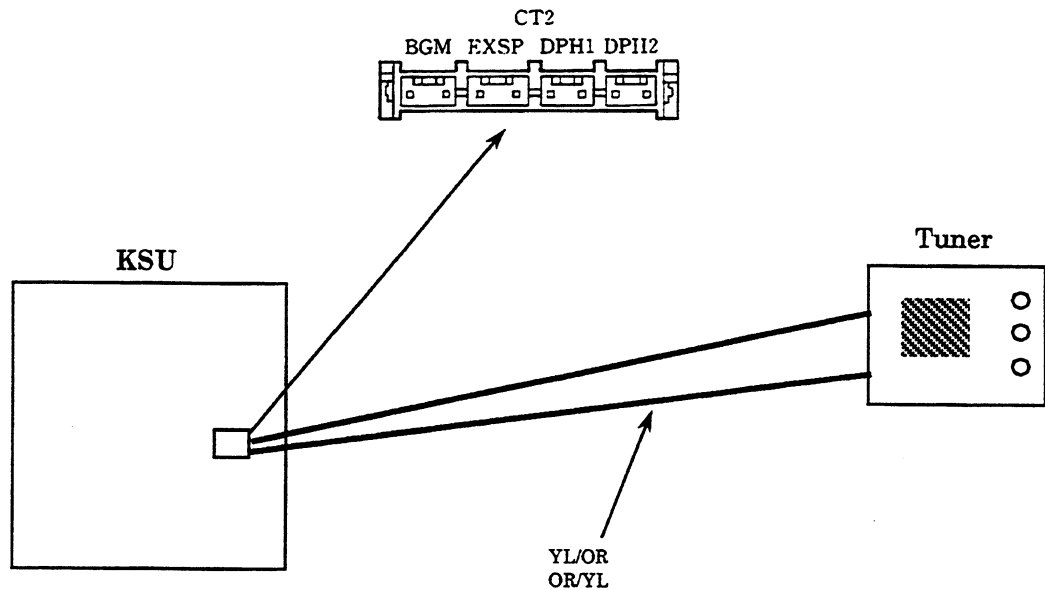

Figure 1-93 MOH/BGM Cable Shield Ground Exposed

9.3 External Paging

Audio output for external paging is a standard feature available at the EXSP jack on the KSU main board. Shielded-audio cable should be used for external paging audio connections.

The KSU provides one audio output to use for paging with Meet-Me Answer. This output is labeled EXSP. A maximum of one zone of external paging can be installed in a system.

The audio output must be connected to a locally provided amplifier and speaker(s). Only 1-way paging is available. For connection information to a locally provided amplifier, refer to Figure 1-94 - External Amplifier with Control Terminal. For external paging audio output level and impedance, refer to Section 2.12 - External Equipment Interface in this chapter.

With a locally provided amplifier, only one zone of paging and background music can be provided. A control relay may be provided for control of the external switching for applications with background music.

When External Paging is answered by Meet-Me Answer, the external paging audio circuit is released.

The EXSP output should not be connected directly to the output of an external amplifier.

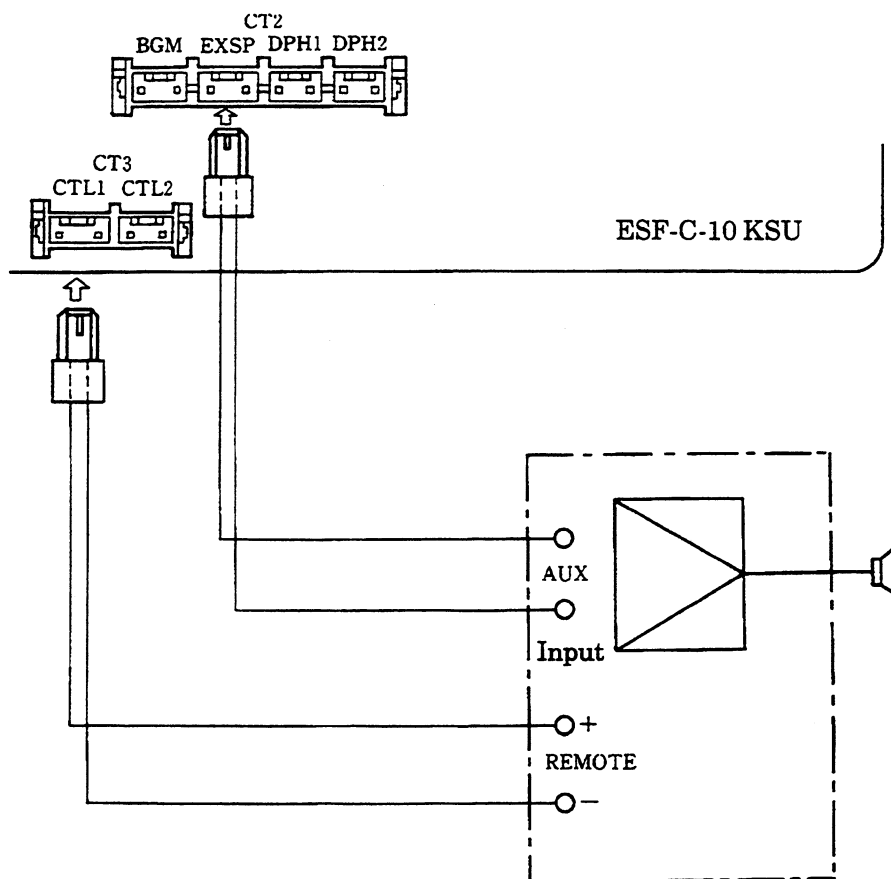

Figure 1-94 External Amplifier with Control Terminal

- Note 1:** The relay contact connected to one of the General Purpose Relays is actuated when the external speaker is operated. The General Purpose Relays can be selected in System Programming.
- Note 2:** Use an external relay with enough capacity to allow ON/OFF control of the power supply of the external amplifier. In addition, ensure that the external relay control current does not exceed 1A.

9.4 Installing Peripherals

A 1-way amplifier speaker must be locally provided for external paging. One General Purpose Relay may be used to switch BGM on and off when required. Refer to Figure 1-95 - External Paging with Background Music.

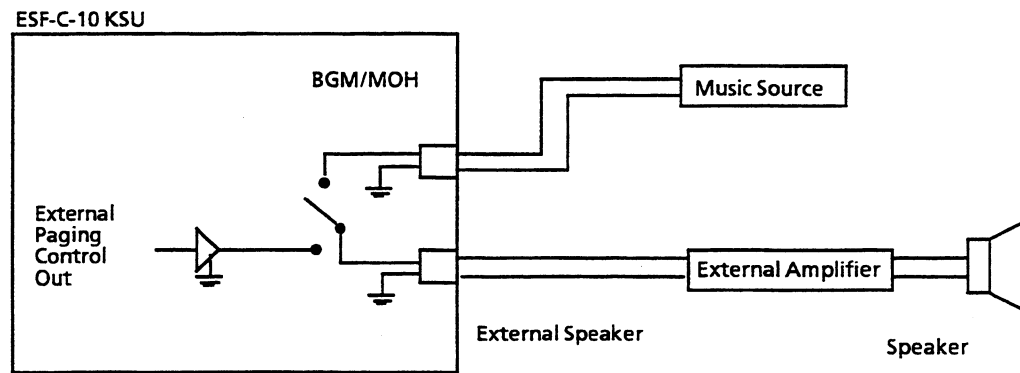

Figure 1-95 External Paging with Background Music

9.5 External Ring Control/Night Chime

An external bell for ringing incoming CO/PBX calls in noisy areas can be connected to the KSU. An interrupted normally-open dry contact is provided for this purpose. One General Purpose Relay can be programmed for this purpose.

An external night chime for ringing incoming CO/PBX calls, (during after hours) in noisy areas can be connected to the KSU. A normally-open dry contact is provided for this purpose. One General Purpose Relay can be programmed for this purpose. Refer to Figure 1-96 - External Ring Control/Night Chime.

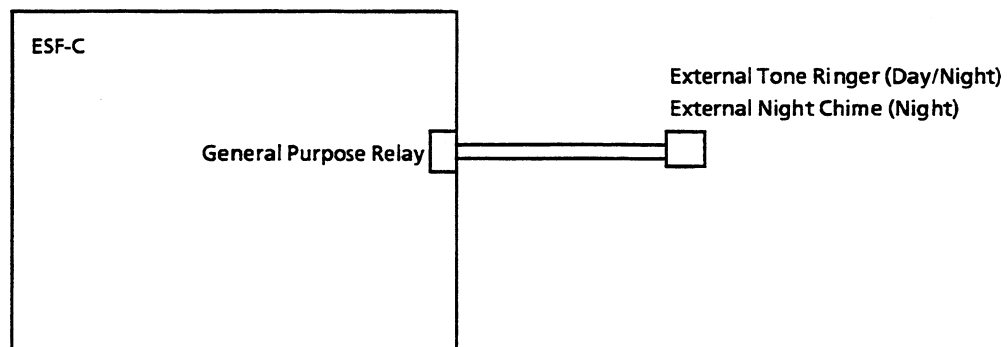

Figure 1-96 External Ring Control/Night Chime

9.6 Doorphones/Door Lock Releases

Two doorphone circuits are built into the KSU. When one doorphone is in use, the other cannot be used. The KSU can also control a door lock release circuit for each doorphone. Two door lock release circuits are also built into the KSU. One or two of the general purpose relays can be used for the door lock release circuits. Refer to Figure 1-97 - Doorphones with Door Lock Release.

A ferrite core must be installed with every Doorphone. Wrap the doorphone cable two turns through the ferrite core.

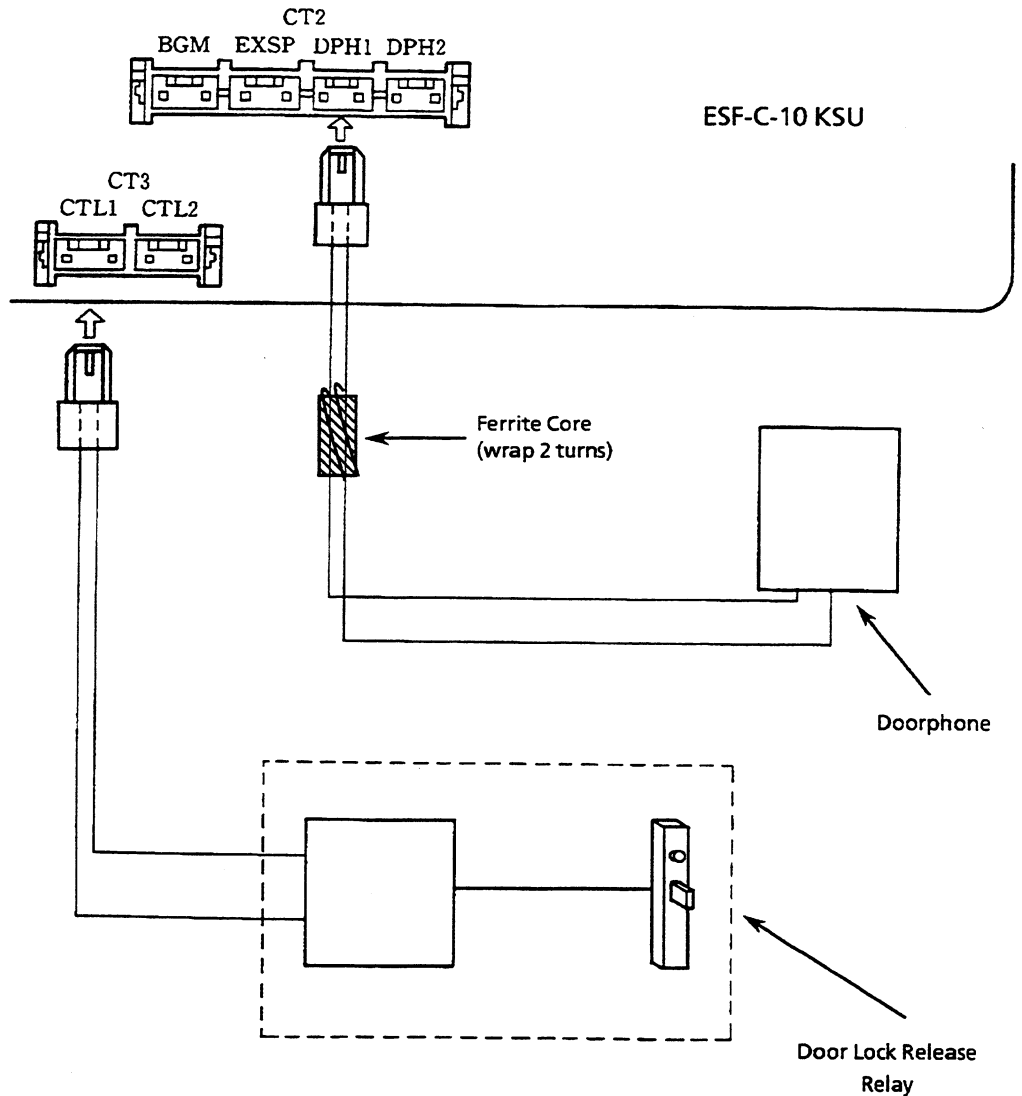

Figure 1-97 Doorphones with Door Lock Release

9.7 Video Doorphone

Locally provided video doorphone equipment can be provided when visual monitoring of an area is required. Refer to Figure 1-98 - Video Doorphone.

A ferrite core must be installed with every video doorphone. Wrap the doorphone cable two turns through the ferrite core.

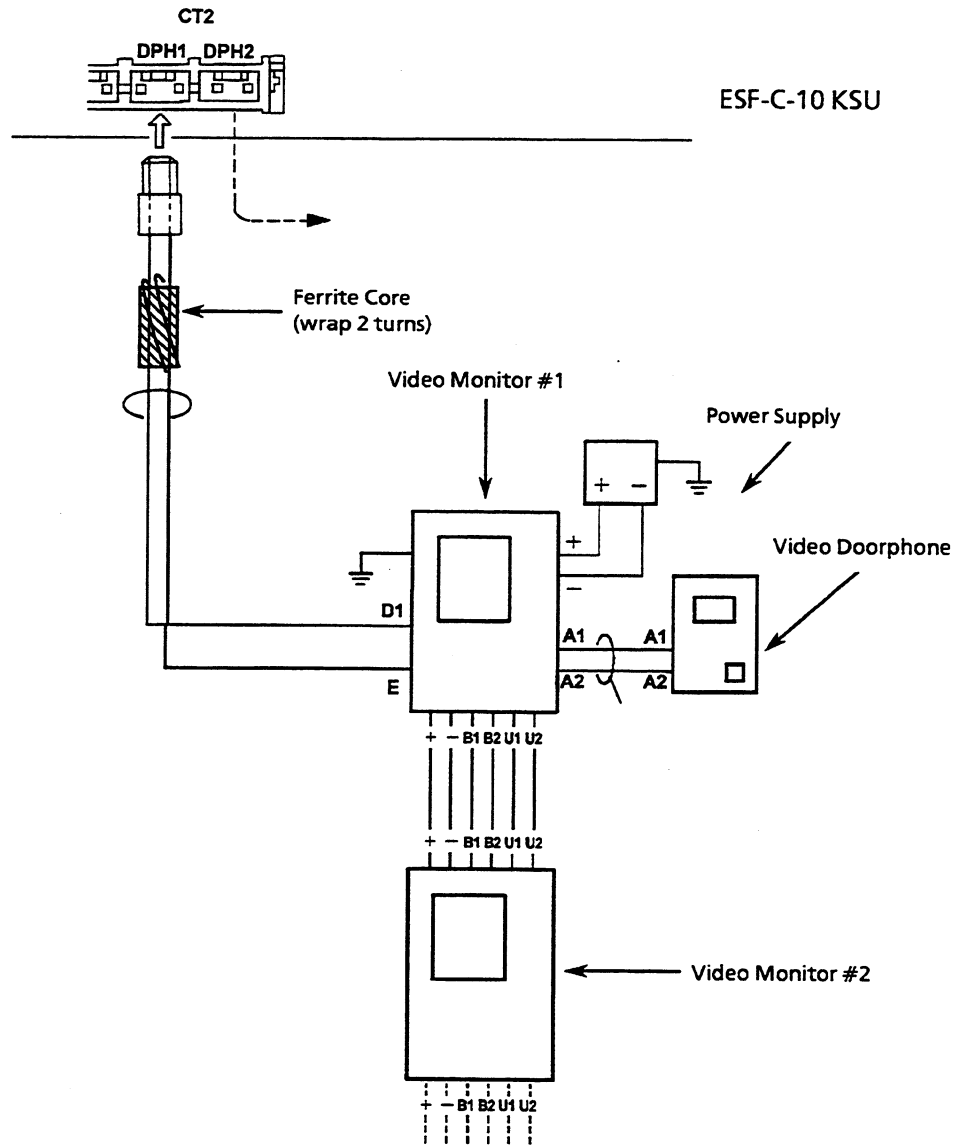

Figure 1-98 Video Doorphone

SECTION 10 LCD INDICATIONS TABLE

The LCD Indications Table shows the LCD displays as they appear on the Multiline Terminal. For ease of use, the information is listed in alphabetical order according to the Display.

Table 1-29 LCD Indications Table

Display	Location	Definition
ADA2 RG ALL SET/CNCL	Originator	Setting/Canceling ADA(2) Ringing Mode (All)
ADA2 RG CMN SET/CNCL	Originator	Setting/Canceling ADA(2) Ringing Mode (Common)
ADA2 RG MODE [X]	Originator	Setting ADA(2) Ringing Mode X = Ring Assignment (0 ~ 2)
ADA2 RG STA SET/CNCL	Originator	Setting/Canceling ADA(2) Ringing Mode (Station)
ALARM X CNCL	Originator	Canceling the Alarm X = Alarm 1 (One Time) Alarm 2 (Daily)
ALARM: X	Originator	Alarm X = Alarm 1 (One Time) Alarm 2 (Daily)
ALARMX 00:00	Originator	Setting Alarm Time X = Alarm 1 (One Time) Alarm 2 (Daily)
ALARMXYY:YY	Originator	Displays Alarm Time X = Alarm 1 (One Time) Alarm 2 (Daily) YY:YY = Time
ALL ALARM CNCL	Originator	Canceling Alarm System-Wide
ALL FWD CNCL	Originator	Canceling Call Forward - All Calls System-Wide
ALL PAGE	Originator	Internal/External All Paging
ALL VRS MSG DEL	Originator	Deleting all Voice Recording Service - Internal Messages
BATTERY LOW	All Stations with LCD	Low Battery
BGM OFF	Originator	Turns off Background Music
BGM ON	Originator	Turns on Background Music
BUSY	Originator	Busy Indication
CALLBACK CNCL	Originator	Canceling Callback Request
CO LINE	Originator	Type of Line Key
CO LINE X	Originator	Incoming Line Key X = CO/PBX Line 1 ~ 8
DATA ENTRY	Originator	Entering Data via System Programming
DND SET	Originator	Setting Do Not Disturb
DND CNCL	Originator	Canceling Do Not Disturb
DOOR X RELEASE	Originator	Doorlock Release X = Doorphone 1 or 2
DOORPHONE X	Originator	Incoming Doorphone Number X = Doorphone 1 or 2
ENTRY ERROR	Originator	No Speed Dial Number Entered
ERROR	Originator	Error Indication

(Continued on next page.)

Display	Location	Definition
FAX RESERVE CNCL	Originator	Canceling Fax Line Reservation
FAX RESERVE SET	Originator	Setting Fax Line Reservation
FNC LAMP OFF	Originator	Turns off the Function Key LED
FNC LAMP CNCL	Originator	Canceling FNC Lamp System-Wide
FWD CNCL	Originator	Canceling Call Forward - All Calls
FWD BNA →[YY]	Originator	Setting Call Forward - Busy/No Answer YY = Destination Station Number
FWDBN BNA CNCL	Originator	Canceling Call Forward - Busy/No Answer
FWD XX →[YY]	Originator	Setting Call Forward - All Calls XX = Originating Station Number YY = Destination Station Number
GROUP [X]	Originator	Internal Zone Paging X = Zone A ~ C
INT ALL PAGE	Receiving	Receiving Internal All Zone Paging
INT ALL PAGE	Originator	Originating Internal All Zone Paging
LCD CONTROL	Originator	LCD Contrast Control
LINE IDLE	Originator	Trunk Queuing
LNR [*] / SPD [_ _]	Originator	Press LNR/SPD Key
MONITOR CNCL	Originator	Resetting Room Monitor
MONITOR SET	Originator	Setting Room Monitor
MONITORED CNCL	Originator	Resetting Monitored Station
MONITORED SET	Originator	Setting Monitored Station
NIGHT MODE CNCL	Originator	Resetting Night Mode
NIGHT MODE SET	Originator	Setting Night Mode
NO ADA2	Originator	ADA(2)-W (BK)/(SW) Unit not installed
NO SMDR	Originator	Station Message Detail Recording Not Installed
NO PRINTER	Originator	Printer not Connected
NO VRS	Originator	Voice Recording Service Not Installed
OFFHOOK RING CTL	Originator	Off-Hook Ringing Control
OVRD - →[XX]	Originator	Barge-In on Station XX = Destination Station Number
OVRD→CO[X]	Originator	Barge-In on CO X = CO/PBX Line 1 ~ 8
PBX LINE	Originator	Type of Line Key
PBX LINE X	Originator	Incoming Line Key X = CO/PBX Line 1 ~ 8
PBX NIGHT CNCL	Originator	Resetting PBX Night Mode
PBX NIGHT SET	Originator	Setting PBX Night Mode
PRINTER TROUBLE	Originator	Printer Problems
PROGRAM MODE	Originator	Programming Mode

(Continued on next page.)

Display	Location	Definition
RECALL:LKX	Originator	Hold Recall X = CO/PBX Line 1 ~ 8
RING CONTROL	Originator	Ring Control
SPKR	Originator	External Paging
SYSTEM REFRESH	Originator	System Refreshes
TEST PRINT	Originator	Test Print
TRUNK QUE CNCL	Originator	Canceling Trunk Queue
TRUNK QUE SET	Originator	Setting Trunk Queue
VOLUME CNTRL []	Originator	Volume Control
[VM]	Receiving	Voice Mail Message Waiting
VRS DELETED [X]	Originator	Deleting a Voice Recording Service Message X = Message 0 ~ 4
VRS DEL	Originator	Voice Recording Service Message Deleted
VRS MSG [XX]	Originator	VRS Message Retrieve XX = Originating Station Number
VRS MSG DEL [XX]	Originator	Deleting a Voice Recording Service - Internal Message XX = Destination Station Number
VRS MSG DELETED	Originator	Deleted a Voice Recording Service - Internal Message
VRS MSG PLAY [XX]	Originator	Playing a Voice Recording Service - Internal Message XX = Destination Station Number
VRS MSG REC [XX]	Originator	Recording a Voice Recording Service - Internal Message XX = Destination Station Number
VRS NIGHT CNCL	Originator	Resetting Voice Recording Service - Night Mode
VRS NIGHT SET	Originator	Setting Voice Recording Service - Night Mode
VRS NO MSG	Originator	No Voice Recording Service Message
VRS PLAY [X]	Originator	Playing a Voice Recording Service Message X = Message 0 ~ 4
VRS REC [X]	Originator	Recording a Voice Recording Service Message X = Message 0 ~ 4
VRS WEEKEND SET	Originator	Resetting Voice Recording Service - Holiday Mode
VRS WEEKEND CNCL	Originator	Setting Voice Recording Service - Holiday Mode
VRS DAYTIME SET	Originator	Automatic Answer/Automated Attendant Set
VRS DAYTIME CNCL	Originator	Automatic Answer/Automated Attendant Cancel
WAITING TRF LKX	Originator	Setting Hold Free Transfer X = CO/PBX Line 1 ~ 8
■ 7:43 PM SUN 2	All Station with LCD	Night Mode On
7:43 PM SUN 2	All Stations with LCD	Clock/Calendar
XX == [YY]	Originator / Receiving	Intercom Call XX = Originator YY = Destination

(Continued on next page.)

Display	Location	Definition
XX = =[YY] TRANSF	Originator	Automatic Ring Transfer XX = Originator YY = Destination
XX ->[YY] *	Originator	Tone Overriding XX = Originator YY = Destination
XX ->[YY]TRANSF	Originator	Call Forwarding XX = Originator YY = Destination
XX ← -[YY]TRANSF	Receiving	Call Forwarded XX = Originator YY = Destination - OR - Ring Transfer XX = Originator YY = Destination
XX ← -[YY] *	Receiving	Tone Overridden XX = Destination YY = Originator
XX - → [YY] #	Originator	Setting Callback Request XX = Originator YY = Destination
XX - → [YY] 0	Receiving	Setting Automatic Callback XX = Destination YY = Originator
XX ← -[YY] URGENT	Receiving	Voice Over Destination XX = Destination YY = Originator
XX - → [YY] URGENT	Originator	Voice Over Source XX = Originator YY = Destination
[XX][YY][ZZ]	Originator	Callback Request XX, YY and ZZ = Callback Station Numbers
"XX" "YY" "ZZ"	Originator	Voice Recording Service - Internal Message XX, YY and ZZ = VRS Setting Station Number
XX =TEL YY	Originator	Telephone Number XX = Station Number YY = Port Number
XX:EMPTY	Originator	Speed Dial Number Confirmation with No Data Entered XX = Buffer Number

(Continued on next page.)

Display	Location	Definition
XX.YYYYYYYYYYYY	Originator	Originating Speed Dial Call XX = Buffer Number YY = Telephone Number - OR - Speed Dial Number Confirmation XX = Buffer Number YY = Telephone Number
XX == DOORPHONE Y	Originator	Doorphone Call XX = Originating Station Number Y = Doorphone 1 or 2
<XX>XX	Receiving	Conference Party Placed On Hold XX = Station Number
[XX] LY LY		Two CO/PBX Line Conference XX = Station Number Y = CO/PBX Line Number

SECTION 11 FEATURE ACCESS CODES

This table shows the Access Codes used in the system. Some codes are set as system defaults and some codes have no default defined but are programmable in System Programming. The table is divided according to the status of the telephone. An explanation of the notes column is listed below; these are referenced throughout the table. Refer to Table 1-30 - Access Code Tables.

Explanation of Notes Column:

Installation: Operable only on telephones specified at the time of installation.

Single Line Only: Operable only on Single Line Telephones.

Single Line OK: Operable on Multiline Terminals or Single Line Telephones.

Note 1: The controls in parentheses are not necessary for your own telephone or own tenant.

Note 2: Enter the new values in the Access Code Table.

Note 3: No system default is defined; this code must be assigned in System Programming.

Table 1-30 Access Code Tables

When the telephone is idle (handset is on-hook):

Function	Operation	Notes
Internal Dial Tone	FNC → Dial 0	
Microphone ON/OFF	FNC → Dial 1	
Mute	FNC → Dial 2	
Verify Station Number	FNC → Dial 4	
Set Timed Alarm	FNC → Dial XXX → Dial YY:YY → FNC XXX = 510 One Time Alarm 520 Daily Alarm YY:YY Time according to 24-hour clock	
Confirm Timed Alarm	FNC → Dial XXX → FNC XXX = 511 One Time Alarm 521 Daily Alarm	
Cancel Timed Alarm	FNC → Dial XXX → FNC XXX = 512 One Time Alarm 522 Daily Alarm	
Cancel Timed Alarm System	FNC → Dial 58 → FNC	Installation
Set/Cancel Do Not Disturb	FNC → Dial 60 → FNC	
Set Call Forward - All Calls	FNC → Dial 61 → Dial XX → FNC XX = Station number where call is to be transferred	Installation
Cancel Call Forward - All Calls	FNC → Dial 61 → FNC	Installation
Set Call Forward - Busy/No Answer	FNC → Dial 62 → Dial XX → FNC XX = Station Number where call is to be transferred	Installation
Cancel Call Forward - Busy/No Answer	FNC → Dial 62 → FNC	Installation
Cordless Telephone Ringing	FNC → Dial 63X → FNC X = 0 (All Mode) 1 (Station Mode) 2 (Common Mode)	Installation
FAX Reservation	FNC → Dial 694 → FNC	
VRS Message Record	FNC → Dial 70X → FNC X = 0 Hold Message 1 A.A./Auto Answer (Night) 2 A.A./Auto Answer (Day) 3 A.A./Auto Answer (Weekend) 4 Manual Message	Attendant Only

(Continued on next page.)

Function	Operation	Notes
VRS Message Verify	FNC → Dial 71X → FNC X = 0 Hold Message 1 A.A./Auto Answer (Night) 2 A.A./Auto Answer (Day) 3 A.A./Auto Answer (Weekend) 4 Manual Message	Attendant Only
VRS Message Clear	FNC → Dial 72X → FNC X = 0 Hold Message 1 A.A./Auto Answer (Night) 2 A.A./Auto Answer (Day) 3 A.A./Auto Answer (Weekend) 4 Manual Message	Attendant Only
VRS Internal Message	FNC → Dial 77 to Set FNC → Dial 78 to Confirm FNC → Dial 79 to Cancel	
Cancel VRS (System--Wide)	FNC → Dial 9	
Set/Cancel Night Mode Switch (System)	FNC → Dial 80 → FNC	Installation Attendant Only
Set/Cancel Auto Attendant/Auto Answer	FNC → Dial 8 X → FNC X = 1 Night 2 Day 3 Weekend	Attendant Only
FNC LED Cancel (System-Wide)	FNC → Dial 88 → FNC	Installation
SMDR Test Print	FNC → Dial 9 * → FNC	Installation
Cancel FNC LED	FNC → Dial 99 → FNC	
Program System Speed Dial Buffer Number	FNC → LNR/SPD → Dial XX → Dial YY → Dial ZZ ~ Z → FNC XX = Speed Dial Buffer Number (20 ~ 99) YY = Access Code (maximum two digits) ZZ ~ Z = Telephone Number (maximum 24 digits)	Installation
Program Station Speed Dial Buffer Number	FNC → LNR/SPD → Dial XX → Dial YY → Dial ZZ ~ Z → FNC XX = Speed Dial Buffer Number (00 ~ 19) YY = Access Code (maximum two digits) ZZ ~ Z = Telephone Number (maximum 24 digits)	
Confirm System Speed Dial Number	CNF → LNR/SPD → Dial XX XX = Speed Dial Buffer Number (20 ~ 99)	
Confirm Station Speed Dial Number	CNF → LNR/SPD → Dial XX XX = Speed Dial Buffer Number (00 ~ 19)	
Clear System Speed Dial Number	FNC → LNR/SPD → Dial XX → FNC XX = Speed Dial Buffer Number (20 ~ 99)	Installation
Clear Station Speed Dial Number	FNC → LNR/SPD → Dial XX → FNC XX = Speed Dial Buffer Number (00 ~ 19)	
Place a Call - Speed Dial	LNR/SPD → Dial XX XX = Speed Dial Buffer Number (00 ~ 99)	

(Continued on next page.)

Function	Operation	Notes
Confirm Last Number Dialed Memory	CNF → LNR/SPD → Dial *	
Place a Call Using Store and Repeat/Save and Repeat	LNR/SPD → Dial #	
Set/Cancel Answer Preset (Ring Line Preference)	FNC → ANS	
Last Dialed Number Memory to a Station Speed Dial Buffer Number	FNC → LNR/SPD → Dial XX → LNR/SPD → FNC XX = Speed Dial Buffer Number (00 ~ 19)	
BGM Station Speaker (On/Off)	FNC → Dial 93 → FNC	
Privacy Release	FNC → Dial 7 → FNC	
Handset Microphone Control	FNC → Dial 2	
Voice Over (Originate)	FNC → *	
Voice Over (Answer)	Press HOLD Key	
Room Monitor Terminal (Monitored)	FNC → Dial 56 → FNC	
Room Monitor Terminal (Monitor)	FNC → Dial 57 → FNC	
Confirm Feature Access Key/One-Touch Key	FNC → Feature Access Key/One-Touch Key	
Cancel Feature Access Key/One-Touch Key	FNC → LNR/SPD → Feature Access Key/One-Touch Key → FNC	
Place a Call with Feature Access Key/One-Touch Key	Press the Feature Access Key/One-Touch Key programmed for the desired feature.	
Program Feature Access Key/One-Touch Key (for DSS/BLF)	FNC → LNR/SPD → Feature Access Key/One-Touch Key → Dial 1 → Dial YY → [Dial 1] → FNC YY = Station Number (2 digits) Operations enclosed in [] are optional. Dialing 1 in this optional step switches the call from Voice to Tone or from Tone to Voice.	
Program Feature Access Key/One-Touch Key (for Station/System Speed Dial)	FNC → LNR/SPD → Feature Access Key/One-Touch Key → Dial 0 → Dial ZZ → FNC ZZ = Station or System Speed Dial Buffer Number	
Program Feature Access Key/One-Touch Key (for Nesting Dial)	FNC → LNR/SPD → Speed Dial Buffer Number → Dial Y → ANS → Dial ZZ → [ANS → Dial ZZ (repeat up to 3 times)] → FNC Y = CO/PBX Trunk Access Code (maximum 2 digits) ZZ = System or Station Speed Dial Buffer Number (00 ~ 99) Operations enclosed in [] are optional.	
Program Feature Access Key/One-Touch Key (for Feature Access)	FNC → LNR/SPD → Feature Access Key/One-Touch Key → Dial # → Dial YY → FNC YY = Feature Access Code (up to seven digits)	

While the station is being seized (handset is lifted or the SPKR key is pressed and ICM LED is lit):

Note: The default settings for the Access Codes are shown in this table.

Function	Operation (Default)	Notes
Off-Hook Ring	Dial 60	
Door/Monitor (Originate)	Dial 61: Doorphone 1 Dial 62: Doorphone 2	
Call Pickup in Same Tenant	Dial 6 *	
Call Pickup - All	Dial 6 #	
Specify CO/PBX Line Seizure	Dial 63 → X X = CO/PBX Line Number (1 ~ 8)	
Set Trunk Queuing	Dial 64 → Hang Up Note: When busy tone is heard.	Installation
Cancel Trunk Queuing	Dial 65 → Hang Up	Installation
Fax Reservation	Dial 694 → Hang Up	Single Line OK
Internal All Zone Paging	Dial 70	
Internal Zone A Paging	Dial 71	
Internal Zone B Paging	Dial 72	
Internal Zone C Paging	Dial 73	
Answer a Page with Meet-Me (All Internal Zones)	Dial 7 *	
External Paging	Dial 75	
All Internal/External	Dial 77	
Answer a Page with Meet-Me (External Page)	Dial 7 #	
Trunk Group (0 ~ 2)	Dial XX XX = 9 (Group 0) 80 (Group 1) 81 (Group 2)	Note 3
Call Attendant 1	Dial 0	
Call Attendant 2	Dial 11	
Program Station Speed Dial Buffer Number	Dial 85 → Dial XX → Dial YY → Dial ZZ ~ Z XX = Speed Dial Buffer Number (00 ~ 19) YY = Trunk Access Code (maximum 2 digits) ZZ ~ Z = Telephone Number (maximum 24 digits)	Single Line Only Note 2
Clear Station Speed Dial Buffer Number	Dial 85 → Dial XX → Hang Up XX = Speed Dial Buffer Number (00 ~ 19)	Single Line Only Note 2

(Continued on next page.)

Function	Operation (Default)	Notes
Place a Call Using a Speed Dial Buffer Number	Dial # → Dial XX # = MF Type XX = Speed Dial Buffer Number (00 ~ 99)	Single Line Only
Last Number Dialed	Dial * * = MF Type	Single Line Only
Interrupt a Call on CO/PBX Line (Barge-In with Station Number)	FNC → CNF → Dial XX → FNC XX = Station Number to be interrupted	Single Line Only Installation
Interrupt a Call on CO/PBX Line (Barge-In with CO/PBX Line Number)	FNC → CNF → Dial * → Dial X → FNC X = CO/PBX Line Number (1 ~ 8)	Installation

While calling a station:

Function	Operation	Notes
Tone/Voice Switching	Dial 1	
Callback Request	Dial #	Installation

While a call is waiting (when calling a station and Call Waiting Tone is heard):

Function	Operation	Notes
Automatic Callback	Dial 0 → Hang Up	Installation
Step Call	Dial 1	Single Line OK (only for DTMF type telephones)
Tone Override	Dial *	Installation
Callback Request	Dial #	Installation

While seizing a CO/PBX line:

Function	Operation	Note
Microphone ON/OFF	FNC → Dial 1	
Seize Outside Line Number Display	FNC → Dial 3	
Store and Repeat	FNC → Dial * → XXX—XXXX XXX - XXXX = Telephone Number	
Save and Repeat	FNC → Dial #	
Exclusive Hold	FNC → HOLD	
Unsupervised Conference	Press CNF key during normal conference	
Privacy Release	FNC → CNF	
Automatic Redial	FNC → LNR/SPD	
Drop Key	FNC → 5	

THIS PAGE INTENTIONALLY LEFT BLANK

CHAPTER 2

PROGRAMMING

CHAPTER 2

PROGRAMMING

TABLE OF CONTENTS

SECTION 1	GENERAL	2-1
1.1	Introduction	2-1
1.2	Using This Chapter	2-1
1.3	Entering the Programming Mode	2-1
1.4	System Data Programming	2-2
SECTION 2	SYSTEM PROGRAMMING	2-3
2.1	Features	2-3
2.2	System Programming	2-3
2.3	Preparation Before Programming	2-3
2.4	Writing System Data	2-4
2.5	Programming Methods	2-4
2.5.1	Initializing the System	2-4
2.5.2	To Use the Multiline Terminal for Programming	2-5
2.5.3	Data Entry Selection	2-9
2.5.4	Confirmation	2-11
2.6	Test	2-11
SECTION 3	SYSTEM DATA LIST	2-13
LK 1	System Mode	2-13
LK 2	Tenant Mode	2-18
LK 3	CO/PBX Line Mode	2-18
LK 4	Telephone Mode	2-19
FNC	Special Mode	2-20
SECTION 4	PROGRAMMING PROCEDURES	2-21
Memory		
Block	LK 1 System Mode	
1-01	Hookflash Time Selection (Multiline Terminal)	2-22
1-02	Hold Recall Timer Selection (Non-Exclusive)	2-23

Memory**Block LK 1 System Mode (continued)**

1-03	Exclusive Hold Recall Timer Selection.	2-24
1-04	Internal/External Paging Access Time Selection	2-25
1-05	Trunk Queuing Recall Time Selection	2-26
1-06	Pause Time Selection.	2-27
1-07	DP Interdigit Time Selection.	2-28
1-08	Receiver (PBR) Release Timer Selection	2-29
1-09	Doorphone Display Time Selection.	2-30
1-10	CO Transfer Recall Timer Selection	2-31
1-11	Automatic Callback Time Selection	2-32
1-12	Automatic Redial Time Selection	2-33
1-13	Bounce Protect Time Selection	2-34
1-14	Hookflash Start Time Selection.	2-35
1-15	Hookflash End Time Selection	2-36
1-16	Call Forward Busy/No Answer Timer Selection.	2-37
1-17	Trunk-to-Trunk Transfer Automatic Disconnect Time Selection	2-38
1-18	Elapsed Call and SMDR Start Timer Selection.	2-39
1-19	Disconnect Time Selection	2-40
1-20	Automatic Release Disconnection Signal Detection Time Selection	2-41
1-21	Voice/Tone Signal Selection	2-42
1-22	BGM Selection	2-43
1-23	System Speed Dial Override Selection	2-44
1-24	System Speed Dial Display Station Selection.	2-45
1-25	Ring Transfer Selection.	2-46
1-26	Time Display (12h/24h) Selection.	2-47
1-27	Day/Night Mode Switching Time Assignment	2-48
1-28	Receiving Volume Selection	2-49
1-29	Barge-In Alert Tone Assignment.	2-50
1-30	External Speaker Connection Selection	2-51

Memory**Block LK 1 System Mode (continued)**

1-31	PBX/CTX Access Code Assignment	2-52
1-32	Private Line Assignment	2-53
1-33	Doorphone Connection Selection	2-54
1-34	SLT Hookflash Signal Selection	2-55
1-35	Station Master Hunt Number Selection.	2-56
1-36	CO/PBX Access/Release Selection.	2-57
1-37	VRS Message Recording Time Selection	2-58
1-38	VRS/VM Automatic Answer/Automated Attendant (Night) Selection	2-59
1-39	VRS/VM Automatic Answer/Automated Attendant (Day) Selection.	2-60
1-40	VRS/VM Automatic Answer/Automated Attendant (Weekend) Selection.	2-61
1-41	VRS Manual Answer Selection.	2-62
1-42	VRS Automatic Answer/Automated Attendant (Night) Time Assignment	2-63
1-43	VRS Automatic Answer/Automated Attendant (Day) Time Assignment.	2-64
1-44	VRS Automatic Answer/Automated Attendant (Off) Time Assignment	2-65
1-45	Doorphone Preference Selection	2-66
1-46	Manual Line Seizure Selection	2-67
1-47	Hold Free Transfer Selection.	2-68
1-48	General Purpose Relay Assignment	2-69
1-49	Synchronous Ringing Selection.	2-70
1-50	Elapsed Call Time Display Selection	2-71
1-51	Music On Hold Selection	2-72
1-52	External MOH Selection	2-73
1-53	External Ring Selection.	2-74
1-54	Night Chime Selection.	2-75
1-55	Class of Service Feature Selection	2-76
1-56	8-Digit Matching Table Assignment	2-77
1-57	Class Allow/Deny Assignment	2-78
1-58	8-Digit Matching Table to Class Assignment	2-79

Memory**Block LK 1 System Mode (continued)**

1-59	8-Digit Matching Table Trunk Group Assignment	2-80
1-60	OCC Table Assignment	2-81
1-61	OCC Table to Trunk Group Assignment	2-82
1-62	8-Digit Matching Table to OCC Table Assignment	2-83
1-63	Internal/External Paging Alert Tone Selection	2-84
1-64	SLT Transfer Selection	2-85
1-65	Printer Connected (Alarm) Selection	2-86
1-66	SMDR Print Format	2-87
1-67	Voice Mail Access Code Assignment	2-88
1-68	Voice Mail DTMF Delay Timer Selection	2-89
1-69	Voice Mail DTMF Duration/Interdigit Time Selection	2-90
1-70	System Refresh Timer Selection	2-91
1-71	VRS Answer Mode Selection	2-92
1-72	VRS/VM Automated Attendant Answer Delay Time Assignment	2-93
1-73	Automated Attendant PBR Release Timer Selection	2-94
1-74	Automated Attendant Delay Ringing Time Selection	2-95
1-75	Automated Attendant No Answer Disconnect Time Selection	2-96
1-76	Automated Attendant No DTMF Detect Selection	2-97
1-77	Automated Attendant Access Code Assignment	2-98
1-78	Fax Line Reservation Timer Selection	2-99

Memory**Block LK 2 Tenant Mode**

2-01	Trunk to Tenant Assignment	2-101
------	--------------------------------------	-------

Memory**Block LK 3 CO/PBX Mode**

3-01 ~ 3-06	Telephone Number to Trunk Assignment (CO 1 ~ 6)	2-103
3-07	CO/PBX DTMF Duration/Interdigit Assignment	2-104
3-08	Trunk Status Selection	2-105
3-09	Trunk Type Selection	2-106

Memory**Block LK 3 CO/PBX Mode**

3-10	CO Line Selection (Installed, DP, DTMF)	2-107
3-11	Trunk-to-Trunk Group Assignment	2-108
3-12	CO/PBX Line Code Restriction Override Selection	2-109
3-14	Trunk-to-Trunk Transfer Yes/No Selection	2-110
3-15	VRS/VM Automatic Answer Yes/No Selection	2-111
3-16	PBX Night Transfer Selection	2-112
3-17	DP Dial Make Ratio Selection	2-113
3-18	VRS Hold Message Assignment	2-114
3-19	Telephone Number to Trunk Assignment (CO 7)	2-115
3-20	Telephone Number to Trunk Assignment (CO 8)	2-116

Memory**Block LK 4 Telephone Mode**

4-01	SLT Connected Yes/No Selection	2-117
4-02	Telephone to Tenant Assignment	2-118
4-03	Internal Zone Paging Selection	2-119
4-04	Ringling Line Preference Selection	2-120
4-05	DTMF/DP SLT Type Selection	2-121
4-06	Station Number Assignment	2-122
4-07	Voice Mail/SLT Selection	2-123
4-08	Distinctive Ringing Tone to Telephone Selection	2-124
4-09	3-Minute Alarm Selection	2-125
4-10	HFU Selection	2-126
4-11	Headset Connection Selection	2-127
4-12	Prime Line Assignment	2-128
4-13	Attendant Group Selection	2-129
4-14	Voice Call Block Selection	2-130
4-15	CO/PBX Ring Assignment (Day Mode)	2-131
4-16	CO/PBX Ring Assignment (Night Mode)	2-132
4-17	Doorphone Chime Assignment (Day Mode)	2-133

Memory**Block LK 4 Telephone Mode**

4-18	Doorphone Chime Assignment (Night Mode)	2-134
4-19	Station to Class of Service Feature Assignment (Day Mode).....	2-135
4-20	Station to Class of Service Feature Assignment (Night Mode).....	2-136
4-21	Code Restriction Class Assignment (Day Mode)	2-137
4-22	Code Restriction Class Assignment (Night Mode)	2-138
4-23	Trunk Digit Restriction	2-139
4-24	Automated Attendant Delay Ring Assignment.....	2-140

Memory**Block Special Mode**

FNC-1	ROM Version Confirmation	2-141
FNC-2	System Speed Dial Memory Clear	2-142
FNC-3	Station Speed Dial Memory Clear.....	2-143
FNC-4	System Data Memory Initialize Operation	2-144
	Clock/Calendar Setting	2-145

SECTION 5 FUNCTION TIMER CHART..... 2-147**SECTION 6 GUIDE TO FEATURE PROGRAMMING..... 2-149****SECTION 7 CODE RESTRICTION 2-157**

7.1	General.....	2-157
7.2	Default Assignments	2-157
7.3	Memory Blocks	2-158
7.4	Memory Block Description	2-158
7.4.1	General	2-158
7.4.2	OCC Assignment/Operation.....	2-158
7.4.3	8-Digit Matching Table Assignment/Operation	2-159
7.4.4	System Speed Dial Override Selection.....	2-160
7.4.5	Trunk Digit Restriction.....	2-160
7.4.6	CO/PBX Line Code Restriction Override Selection.....	2-160
7.4.7	Code Restriction Class Assignment (Day Mode).....	2-160
7.4.8	Code Restriction Class Assignment (Night Mode).....	2-160

- 7.5 Code Restriction Tables 2-161
 - 7.5.1 OCC Tables (Default Values) 2-161
 - 7.5.2 8-Digit Matching Tables (Default Values) 2-162
- 7.6 Code Restriction Algorithm. 2-165
- SECTION 8 DISPLAY ABBREVIATIONS. 2-169**

LIST OF FIGURES

2-1	Programming Flowchart	2-2
2-2	Electra Elite Multiline Terminal	2-5
2-3	Electra Professional Level I System Multiline Terminal.....	2-6

SECTION 1 GENERAL

1.1 Introduction

The Electra Professional Level I system is a stored program controlled system. When the system is initially powered up, the CPU scans each possible interface KTU to determine the hardware configuration. The system stores this information and the system default values in memory. This area of memory is called the Resident System Program. After the system is initially powered up, a trained technician can change the Resident System Program to meet the specific needs of the individual customer.

Before attempting to program the Electra Professional Level I system, the Job Specifications Worksheets should be completed. These worksheets help organize the customer programming needs. Copies of the worksheets should be retained at the job site and on file at the technician office. Refer to the *Electra Professional Level I Job Specifications Manual* included with the KSU.

WARNING

The battery on the KSU Main Board must be on. Failure to ensure the battery is on before programming begins, may result in the loss of data during a power outage.

1.2 Using This Chapter

This chapter is divided into the following sections:

Section 1 - General

Provides a general overview of System Programming.

Section 2 - System Programming

Presents the terms and structure that the technician should be familiar with before attempting to program the system.

Section 3 - System Data List

Presents a complete list of Data Numbers, Timer and Function Names, Default Values, and Timing Values.

Section 4 - Programming Procedures

Provides detailed instructions and procedures for programming all Memory Blocks.

1.3 Entering the Programming Mode

To program information into the Electra Professional Level I system, a DTU-16D-() (BK)/(WH), DTU-32D-() (BK)/(WH), ETW-16DC-1 (BK)/(SW), or ETW-16DD-1 (BK)/(SW) Multiline Terminal can be used as programming stations. Two stations are automatically assigned as programming stations. These stations are assigned to the two lowest interface circuits (Ports 01 and 02) in the system.

When entering any area of programming, the programming station must be OFF-LINE. **To Go Off-Line:**

1. Press Feature (FNC) key, then the Hold (HOLD) key.
2. Dial #, 0, * in sequence.

After the above steps are complete, the LCD on the Multiline Terminal shows:

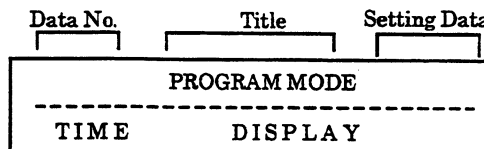

While the programming terminal is OFF-LINE it cannot be signaled by any station in the system.

Note: The off-line mode does not time out.

1.4 System Data Programming

System Data Programming may be required for the following reasons:

- When the system is installed for the first time.
- When the KSU is replaced.
- When functions of an existing system are changed.

Refer to Figure 2-1 - Programming Flowchart for more information. Types of System Data include: System Mode Data, Tenant Mode Data, CO/PBX Line Mode Data, Telephone Mode Data, and Special Mode Data.

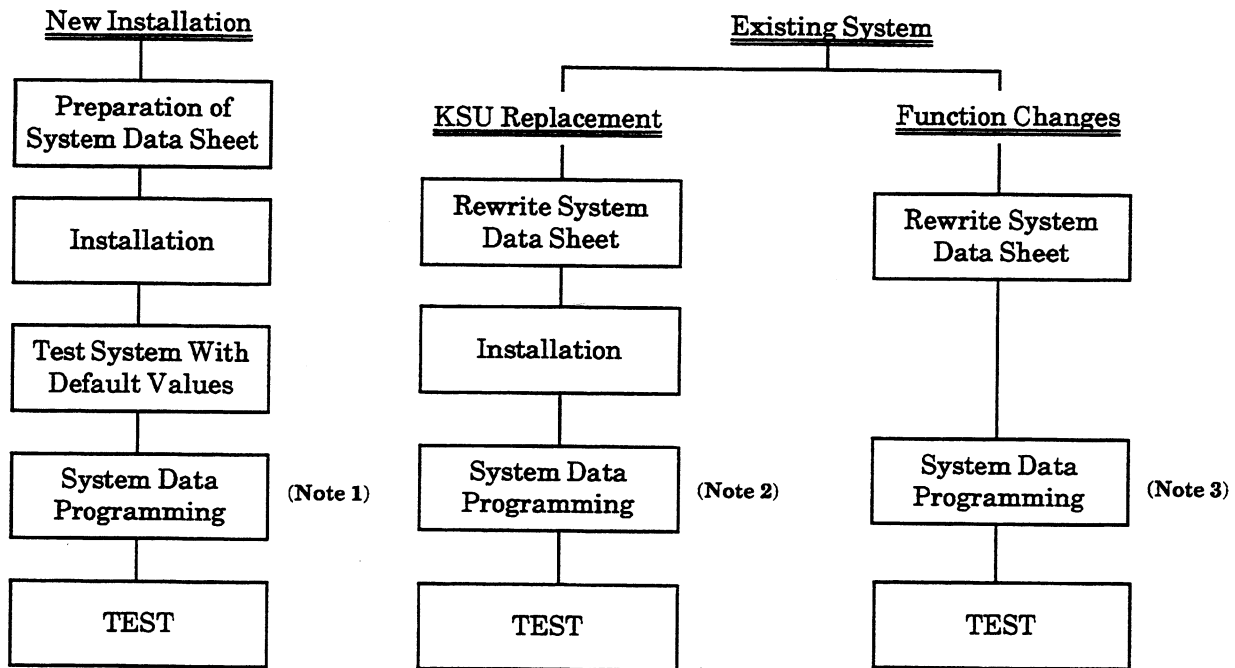

Note 1: In new installations, system default values are assigned when the power is turned on. Therefore, program only the System Data to be changed.

Note 2: In KSU replacement, program the relevant System Data.

Note 3: In function changes, program the System Data that is to be revised.

Figure 2-1 Programming Flowchart

SECTION 2 SYSTEM PROGRAMMING

2.1 Features

The system operates from a default program after initial power up. Program only the parameters that need to be changed from the default assignment.

The System Programming characters are displayed on the LCD.

Only the first two Multiline Terminal Stations (10 and 11) can be used to program the system.

2.2 System Programming

System Programming is divided into five modes.

- 1 System Mode
- 2 Tenant Mode
- 3 CO/PBX Line Mode
- 4 Telephone Mode
- 5 Special Mode
 - ROM Version Confirmation
 - Speed Dial Clear (System)
 - Speed Dial Clear (Station)
 - Clear System Data

2.3 Preparation Before Programming

1. Check Points:

- | | |
|-----------------------------|---|
| Confirmation of ROM version | Some features may not be available depending on the ROM version. (Refer to ROM Version Confirmation in Section 4 - Programming Procedures.) |
| Confirmation of Port Number | Port numbers are used for System Programming. |

< Confirmation operation >  → 4

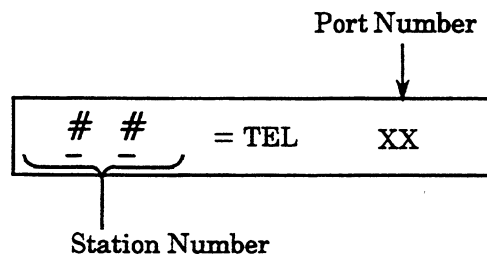

2. Preliminary Points:

- | | |
|----------------------------------|---|
| Selection of System Programming | Refer to Figure 2-1 - Programming Flowchart in Section 1.4 - System Data Programming to select the data to be programmed. |
| Prepare System Programming sheet | Refer to Section 4 - Programming Procedures to enter the data. |

2.4 Writing System Data

After turning the system power on, program System Data from a Multiline Terminal (Port 01 or 02). The Multiline Terminal must be idle. Although System Programming can be performed while other Multiline Terminals are in use, some of the System Programming is registered (written in memory) immediately after the programming process, while other System Programming is not registered until the stations become idle. In the latter case, an in-use station display shows DATA ENTRY after the programming process is completed.

When the in-use station becomes idle, the data is registered and the display shows only the time.

The following System Programming is not registered while certain equipment is in use:

When telephones are in use:

- Memory Block 1-07 DP Interdigit Time Selection
- Memory Block 1-13 Bounce Protect Time Selection
- Memory Block 1-14 Hookflash Start Time Selection
- Memory Block 1-15 Hookflash End Time Selection
- Memory Block 1-19 Disconnect Time Selection
- Memory Block 1-20 Automatic Release Disconnection Signal Detection Time Selection
- Memory Block 3-10 CO Line Selection (Installed, DP, DTMF)
- Memory Block 3-17 DP Dial Make Ratio Selection
- Memory Block 4-01 SLT Connected Yes/No Selection

When VRS is in use:

- Memory Block 1-37 VRS Message Recording Time Selection

When SMDR is in use:

- Memory Block 1-65 Printer Connected (Alarm) Selection
- Memory Block 1-66 SMDR Print Format

2.5 Programming Methods

2.5.1 Initializing the System

Turn the Key Service Unit (KSU) power ON. After approximately 10 seconds, the system operates with system default values.

2.5.2 To Use the Multiline Terminal For Programming

System Programming is performed using a Multiline Terminal (with LCD) connected to Ports 01 and 02.

Refer to Figure 2-2 - Electra Elite Multiline Terminal and 2-3 - Electra Professional Level I System Multiline Terminal for a description of key operations, LED indications, and the display for System Programming.

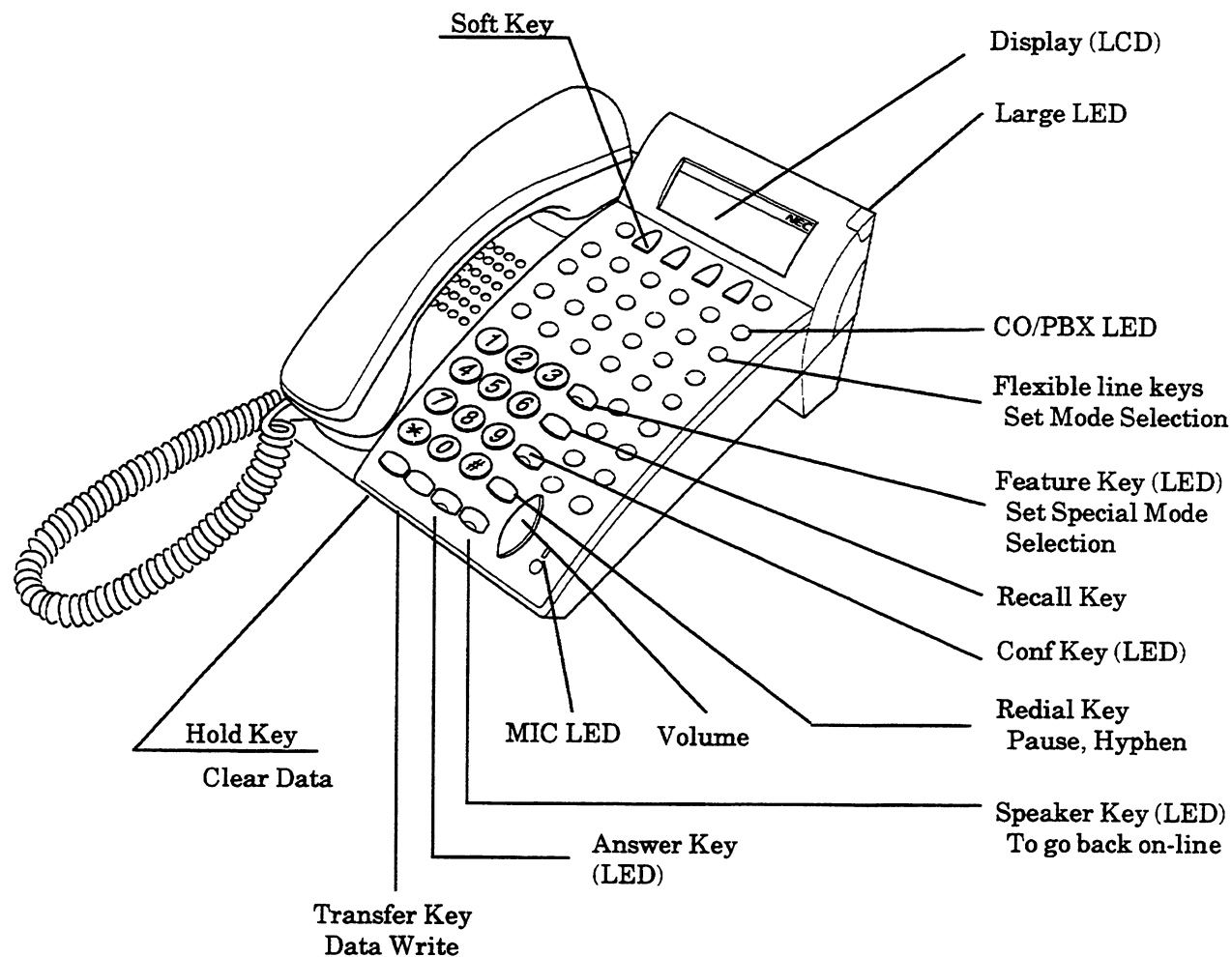

Dial Keys

- * : Cursor movement (to the left)
- # : Cursor movement (to the right)
- 0~9 : Data input (from Dial Pad)

Figure 2-2 Electra Elite Multiline Terminal

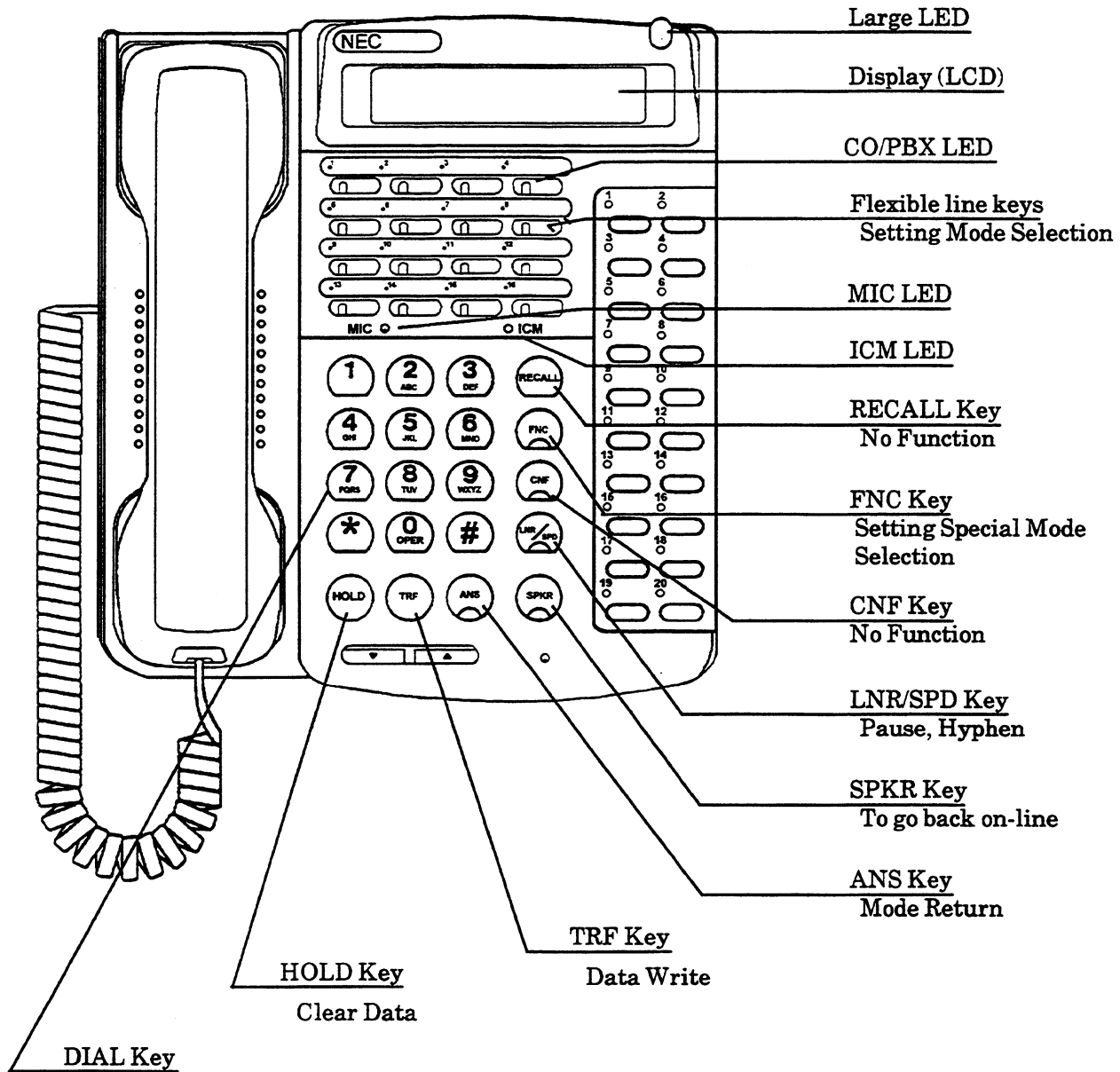

- * : Cursor movement (to the left)
- # : Cursor movement (to the right)
- 0~9 : Data input (from Dial Pad)

Figure 2-3 Electra Professional Level I System Multiline Terminal

1) Key Functions:

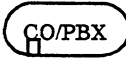
 ----- The Flexible Line keys are used to specify a Mode when selecting a Memory Block or to select programming data for input.

 ----- The FNC (Elite Feature) key is used to select Special Mode.

 ----- The SPKR (Elite Speaker) key is used for exiting the programming mode (go back on-line).

 ----- Used for moving the cursor. The cursor moves one character space to the left each time * is pressed.

 ----- Used for moving the cursor. The cursor moves one character space to the right each time # is pressed.

 ----- The TRF (Elite Transfer) key is used for writing data. After entering data, press the TRF key to write the data into memory and advance to the next Memory Block.



 ----- The ANS (Elite Answer) key is used for selecting another Mode. Press the ANS key to switch Modes as follows:
Returns to PROGRAM MODE.

 ----- The HOLD (Elite Hold) key is used to enter a pause in Speed Dial Programming Mode or to clear data in System Programming Mode.

 ----- The LNR/SPD (Elite Redial) key is used to enter a pause or hyphen, etc., and to enter * and #.

 :  → 

 :  → 

 ~  ----- Used to enter data from the Dial Pad and to specify a Memory Block location in each input mode, or to select programming data for input.

2) Off-Line Program Mode:

A. To go off-line, press:

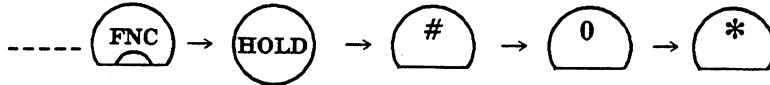

After entering the off-line mode for programming, the following displays appear:

B. Selecting Memory Block locations

System Mode



LK = Line Key

Tenant Mode



CO/PBX Line Mode

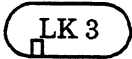

Telephone Mode

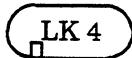

Special Mode



PROGRAM	MODE
TIME	DISPLAY

01 : FLSH	600 ms
TIME	DISPLAY

00 / 01 : TNT - TRK / YS	
TIME	DISPLAY

01 /	
TIME	DISPLAY

00 / 01 : SLT	
TIME	DISPLAY

SPECIAL	MODE
TIME	DISPLAY

2.5.3 Data Entry Selection

System Programming is performed by using the keys on Multiline Terminals (Ports 10 or 11). During programming, System Data is shown on the LCD of the off-line terminal.

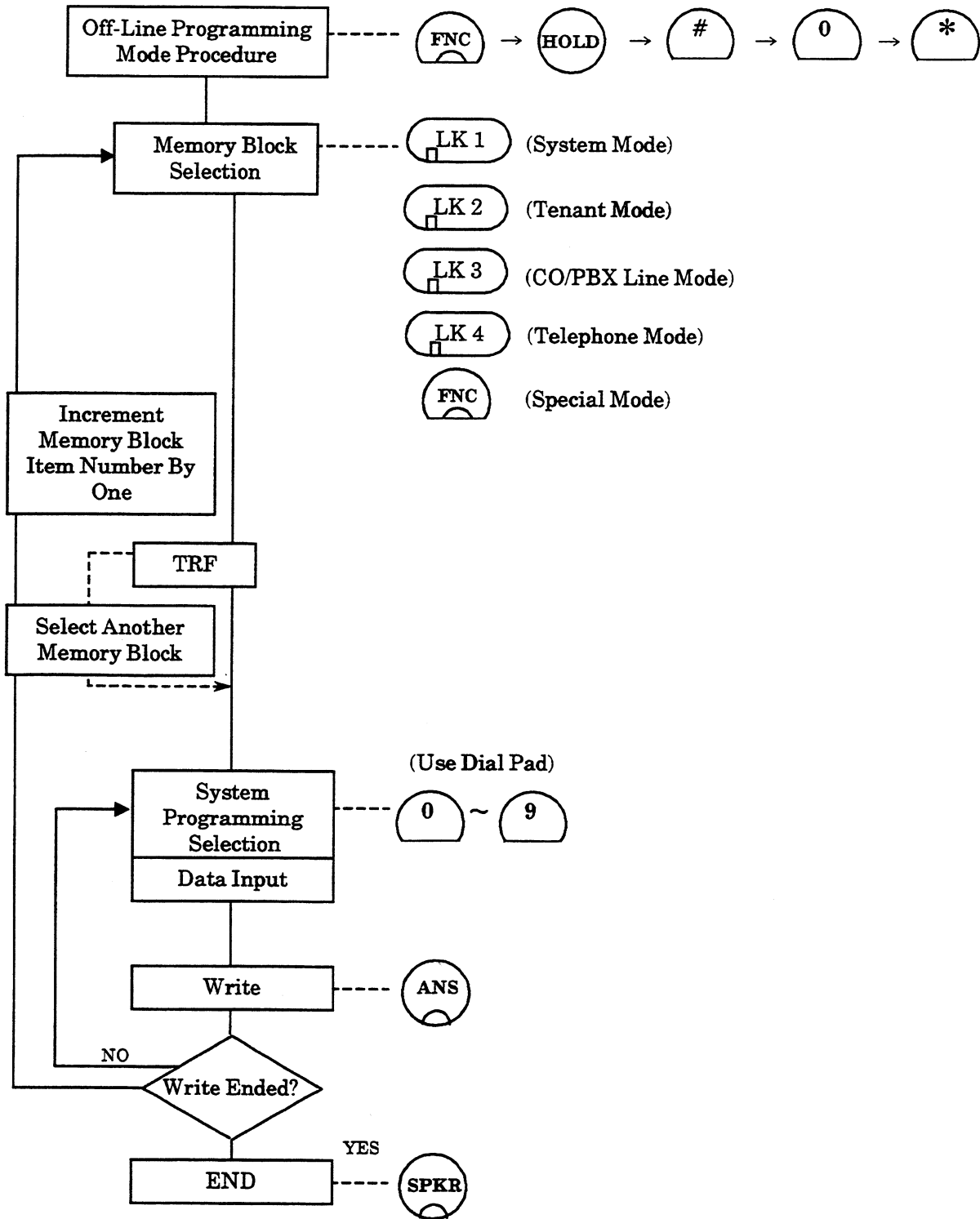

Example: Memory Block 1-11 (Automatic Callback Release Time Selection)
 (Default) → 60 minutes

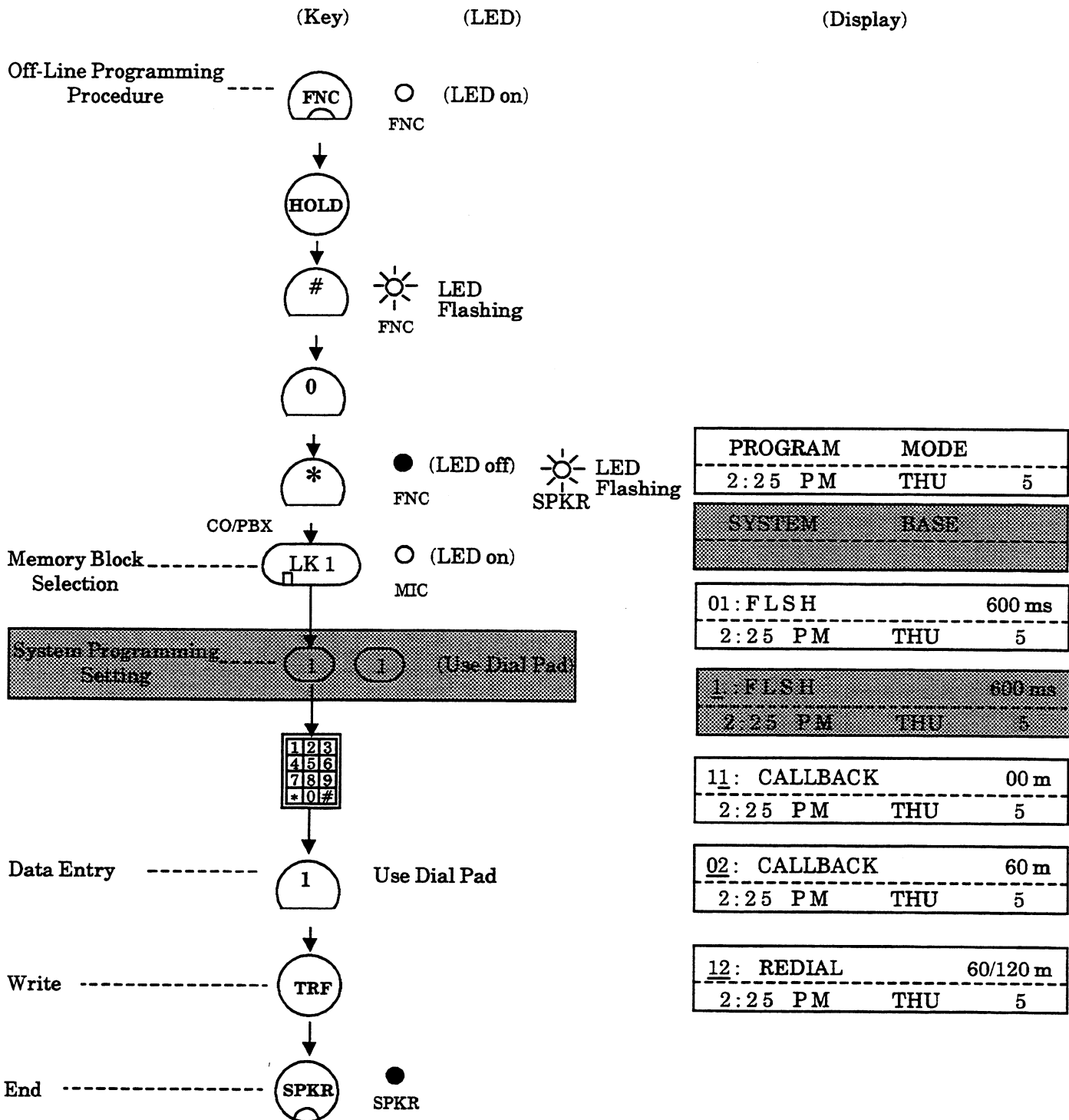

2.5.4 Confirmation

To confirm programmed data, select the desired Memory Block after entering the off-line programming mode and enter the Data Number. The data is shown on the display.

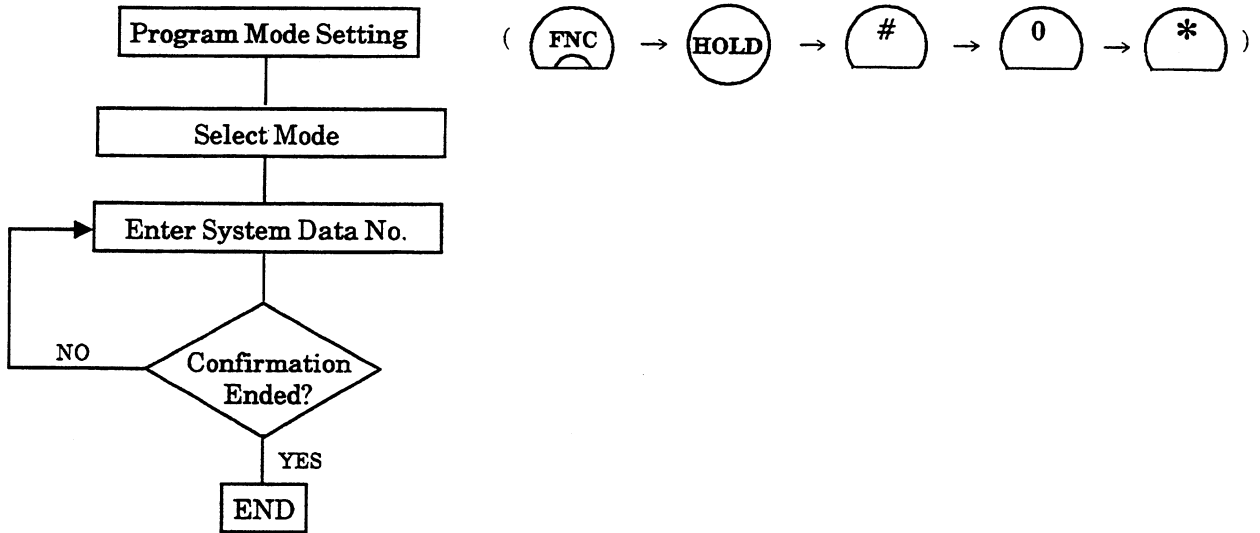

2.6 Test

After completion of programming, test the functions of System Programming for proper operation.

THIS PAGE INTENTIONALLY LEFT BLANK

SECTION 3 SYSTEM DATA LIST

1. SYSTEM MODE LK1

Data No.	Function Name	Default	Programming Value																				
01	Hookflash Time Selection (Multiline Terminal)	600 ms.	60 ms., 100 ms., 140 ms., 200 ms., 400 ms., 600 ms., 800 ms., 1 sec., 1.5 sec., 2 sec.																				
02	Hold Recall Timer Selection (Non-Exclusive)	1 min.	1 min., 2 min., 4 min., No Limit (0m)																				
03	Exclusive Hold Recall Timer Selection	1 min.	1 min., 2 min., 4 min., No Limit (0m)																				
04	Internal/External Paging Access Time Selection	90 sec.	90 sec., 120 sec., No Limit (0s)																				
05	Trunk Queuing Recall Time Selection	10 sec.	10 sec., 20 sec., 30 sec., 60 sec.																				
06	Pause Time Selection	3 sec.	1 sec., 3 sec.																				
07	DP Interdigit Time Selection	Pattern B	Pattern A, Pattern B																				
08	Receiver (PBR) Release Timer Selection	10 sec.	5 sec., 10 sec., 20 sec., 30 sec., 50 sec., 60 sec.																				
09	Doorphone Display Time Selection	10 sec.	10 sec., 30 sec., 60 sec., 90 sec.																				
10	CO Transfer Recall Timer Selection	60 sec.	30 sec., 60 sec., 120 sec., 240 sec.																				
11	Automatic Callback Time Selection	No Limit	30 min., 60 min., 90 min., No Limit (0m)																				
12	Automatic Redial Time Selection	<p><u>Selection = 0</u></p> <p>Calling Time 15 sec.</p> <p>Call Waiting Time 60 sec.</p> <p>Call Attempts 5 times</p>	<table border="1"> <thead> <tr> <th><u>Selection</u></th> <th>0</th> <th>1</th> <th>2</th> <th>3</th> </tr> </thead> <tbody> <tr> <td>Calling Time</td> <td>15</td> <td>15</td> <td>15</td> <td>30</td> </tr> <tr> <td>Call Waiting Time</td> <td>60</td> <td>120</td> <td>180</td> <td>120</td> </tr> <tr> <td>Call Attempts</td> <td>5</td> <td>5</td> <td>5</td> <td>5</td> </tr> </tbody> </table>	<u>Selection</u>	0	1	2	3	Calling Time	15	15	15	30	Call Waiting Time	60	120	180	120	Call Attempts	5	5	5	5
<u>Selection</u>	0	1	2	3																			
Calling Time	15	15	15	30																			
Call Waiting Time	60	120	180	120																			
Call Attempts	5	5	5	5																			
13	Bounce Protect Time Selection	300 ms.	0 ms., 300 ms., 600 ms., 900 ms.																				
14	Hookflash Start Time Selection	300 ms.	100 ms., 150 ms., 200 ms., 300 ms., 350 ms., 450 ms., 550 ms., 650 ms., 750 ms., 850 ms.																				
15	Hookflash End Time Selection	<p>HST + 700 ms.</p> <p>HST = Hookflash Start Time</p>	<p>HST + 0 ms.</p> <p>HST + 100 ms.</p> <p>HST + 200 ms.</p> <p>HST + 400 ms.</p> <p>HST + 500 ms.</p> <p>HST + 700 ms.</p> <p>HST + 900 ms.</p> <p>HST + 1100 ms.</p> <p>HST + 1300 ms.</p> <p>HST + 1500 ms.</p>																				

System Mode LK1 (continued)

Data No.	Function Name	Default	Programming Value
16	Call Forward Busy/No Answer Timer Selection	10 sec.	10 sec., 15 sec., 20 sec., 25 sec., 30 sec., 60 sec.
17	Trunk-to-Trunk Transfer Automatic Disconnect Time Selection	1 hr.	30 min., 1 hr., 2 hr., 3 hr.
18	Elapsed Call and SMDR Start Timer Selection	10 sec.	10 sec., 20 sec., 30 sec.
19	Disconnect Time Selection	1.5 sec.	0.3 sec., 0.5 sec., 0.7 sec., 1.0 sec., 1.5 sec., 2.0 sec., 2.5 sec., 3.0 sec., 3.5 sec., 4.0 sec.
20	Automatic Release Disconnection Signal Detection Time Selection	350 ms.	5 sec., 50 ms., 100 ms., 150 ms., 200 ms., 250 ms., 300 ms., 350 ms., 400 ms., 500 ms.
21	Voice/Tone Signal Selection	Voice	Tone, Voice
22	BGM Selection	No	No, Tel, Speaker, Tel & Speaker
23	System Speed Dial Override Selection	No	No, Yes
24	System Speed Dial Display Station Selection	Attendant Position	Attendant Positions All Multiline Terminals
25	Ring Transfer Selection	Yes	No, Yes
26	Time Display (12h/24h) Selection	12 hr.	12 hr., 24 hr.
27	Day/Night Mode Switching Time Assignment	Not Specified	Day Mode Start Time (24 hours) Night Mode Start Time (24 hours)
28	Receiving Volume Selection	Down	Down, Up
29	Barge-In Alert Tone Assignment	Yes	No, Yes
30	External Speaker Connection Selection	Yes	No, Yes
31	PBX/CTX Access Code Assignment	Access Code 1 9_ Access Code 2 Vacant	Up to six digits (three numeric, three pauses)
32	Private Line Assignment	Not Specified	CO/PBX Line Number, Tel. Port No., up to two lines/two stations
33	Doorphone Connection Selection	Yes	No, Yes
34	SLT Hookflash Signal Selection	Hold	Hold, Flash
35	Station Master Hunt Number Selection	No	No, Yes

System Mode LK1 (continued)

Data No.	Function Name	Default	Programming Value
36	CO/PBX Access/Release Selection	No	No, Yes
37	VRS Message Recording Time Selection	15 sec. × 16 messages	15 sec. × 16 messages 30 sec. × 8 messages 60 sec. × 4 messages 120 sec. × 2 messages
38	VRS/VM Automatic Answer /Automated Attendant (Night) Selection	No	No, Yes
39	VRS/VM Automatic Answer/Automated Attendant (Day) Selection	No	No, Yes
40	VRS/VM Automatic Answer/Automated Attendant (Weekend) Selection	No	No, Yes
41	VRS Manual Answer Selection	No	No, Yes
42	VRS Automatic Answer/Automated Attendant (Night) Time Assignment	Not Specified	00:00 ~ 23:59
43	VRS Automatic Answer/Automated Attendant (Day) Time Assignment	Not Specified	00:00 ~ 23:59
44	VRS Automatic Answer/Automated Attendant (Off) Time Assignment	Not Specified	00:00 ~ 23:59
45	Doorphone Preference Selection	Yes	No, Yes
46	Manual Line Seizure Selection	Yes (Manual Line Seizure)	No, Yes
47	Hold Free Transfer Selection	No	No, Yes
48	General Purpose Relay Assignment	Non	Non, Door Lock Release 1, Door Lock Release 2, External Speaker, MOH/BGM, External Tone Ringer, Fax
49	Synchronous Ringing Selection	Yes	No, Yes
50	Elapsed Call Time Display Selection	Yes	No, Yes
51	Music On Hold Selection	Let It Be	Let It Be, Melody Fair
52	External MOH Selection	No	No, Yes
53	External Ring Selection	Non	Non, Relay, Speaker, Relay and Speaker
54	Night Chime Selection	Non	Non, Relay, Speaker, Relay and Speaker

System Mode LK1 (continued)

Data No.	Function Name	Default	Programming Value
55	Class of Service Feature Selection	Class 0: Feature No. 00, 03~15 (Yes) Feature No. 01, 02 (No) Class 1: Feature No. 03~15 (Yes) Feature No. 00~02 (No) Class 2~7: All (No)	No, Yes No = Deny Yes = Allow
56	8-Digit Matching Table Assignment	Refer to Memory Block.	Refer to Memory Block.
57	Class Allow/Deny Assignment	Class 0 YS (allow) [fixed] Class 1~4 YS (allow) Class 5~6 NO (deny) Class 7 NO (deny) [fixed]	No, Yes No = Deny Yes = Allow
58	8-Digit Matching Table to Class Assignment	Refer to Memory Block.	0 = Deny, 1 = Allow 2 = Deny (OCC calls only) 3 = Allow (OCC calls only)
59	8-Digit Matching Table to Trunk Group Assignment	Enable	0 = Disable 1 = Enable
60	OCC Table Assignment	Refer to Memory Block.	Refer to Memory Block.
61	OCC Table to Trunk Group Assignment	Yes (All OCC Tables Assigned)	No = Not Assigned Yes = All OCC Tables Assigned
62	8-Digit Matching Table to OCC Table Assignment	No	No = Not Assigned Yes = All OCC Numbers Assigned
63	Internal/External Paging Alert Tone Selection	Yes	No, Yes
64	SLT Transfer Selection	Hook	Hook, Hang up
65	Printer Connected (Alarm) Selection	Yes	No, Yes
66	SMDR Print Format	All	All, Mask
67	Voice Mail Access Code Assignment	Code 01~09 = All Blank Code 10 = 641 Code 11 = 64*	Refer to Memory Block.
68	Voice Mail DTMF Delay Timer Selection	1 sec.	0 sec., 0.1 sec., 0.5 sec., 1.0 sec., 2.0 sec., 4.0 sec., 6.0 sec., 8.0 sec., 10 sec., 14 sec.
69	Voice Mail DTMF Duration/Interdigit Time Selection	100/70 ms.	70/60 ms., 100/50 ms., 100/70 ms., 400/100 ms., 600/100 ms., 900/200 ms.

System Mode LK1 (continued)

Data No.	Function Name	Default	Programming Value
70	System Refresh Timer Selection	4 hr.	0 hr. (No Refresh), 4 hr., 8 hr., 12 hr., 24 hr.
71	VRS Answer Mode Selection	No	No = Automatic Answer Yes = Automated Attendant
72	VRS/VM Automated Attendant Answer Delay Time Assignment	3 sec.	0 sec., 3 sec., 6 sec., 12 sec., 18 sec., 24 sec., 30 sec., 36 sec., 42 sec., 48 sec.
73	Automated Attendant PBR Release Timer Assignment	20 sec.	0 sec., 10 sec., 20 sec., 30 sec., 40 sec., 50 sec., 60 sec.
74	Automated Attendant Delay Ringing Time Selection	∞	10 sec., 20 sec., 30 sec., ∞
75	Automated Attendant No Answer Disconnect Time Selection	1 min.	1 min., 2 min., 3 min., 4 min., ∞
76	Automated Attendant No DTMF Detect Selection	Normal Call	Normal Call Release
77	Automated Attendant Access Code Assignment	Not Specified	Refer to Memory Block.
78	Fax Line Reservation Timer Selection	30 sec.	30 sec., 60 sec., 120 sec., 240 sec.

2. TENANT MODE LK2

Data No.	Function Name	Default	Programming Value
01	Trunk to Tenant Assignment	Tenant 00: CO 01~08 = Yes Tenant 01~03: CO 01~08 = No	No, Yes

3. CO/PBX LINE MODE LK3

Data No.	Function Name	Default	Programming Value
01~06	Telephone Number to Trunk Assignment (CO 1~6)	Not Specified	A maximum of 13 digits (numbers, hyphens, spaces)
07	CO/PBX DTMF Duration/Interdigit Assignment	DTMF Digit Duration: 70 ms. Interdigit Time: 60 ms.	70/60 ms., 100/70 ms., 400/100 ms., 600/100 ms., 900/200 ms.
08	Trunk Status Selection	Out and In	Out and In, In
09	Trunk Type Selection	CO	CO, PBX
10	CO Line Selection (Installed, DP, DTMF)	MF	Nil, DP 10 pps, DP 20 pps, MF
11	Trunk-to-Trunk Group Assignment	All CO/PBX Line Nos. = Trunk Group 0	Trunk Group Numbers 0~2
12	CO/PBX Line Code Restriction Override Selection	No	No, Yes
14	Trunk-to-Trunk Transfer Yes/No Selection	No	No, Yes
15	VRS/VM Automatic Answer Yes/No Selection	No	No, VRS, VM
16	PBX Night Transfer Selection	No	No, Yes
17	DP Dial Make Ratio Selection	39%	33%, 39%
18	VRS Hold Message Assignment	No	No (deny) Yes (allow)
19	Telephone Number to Trunk Assignment (CO7)	Not specified	A maximum of 13 digits (includes numbers, hyphens, and spaces)
20	Telephone Number to Trunk Assignment (CO8)	Not specified	A maximum of 13 digits (includes numbers, hyphens, and spaces)

4. TELEPHONE MODE LK4

Data No.	Function Name	Default	Programming Value																		
01	SLT Connected Yes/No Selection	No	No, Yes																		
02	Telephone to Tenant Assignment	All Telephones Tenant 0	Tenant Numbers (0~3)																		
03	Internal Zone Paging Selection	Group A	No, Group A, Group B, Group C																		
04	Ringling Line Preference Selection	No	No, Yes																		
05	DTMF/DP SLT Type Selection	DTMF	DP, DTMF																		
06	Station Number Assignment	<table border="0"> <tr> <td>Tel. Port No.</td> <td>Sta. No. 2-digit</td> </tr> <tr> <td>01</td> <td>10</td> </tr> <tr> <td>02</td> <td>11</td> </tr> <tr> <td>03</td> <td>12</td> </tr> <tr> <td>04</td> <td>13</td> </tr> <tr> <td>05</td> <td>14</td> </tr> <tr> <td>06</td> <td>15</td> </tr> <tr> <td>f</td> <td>f</td> </tr> <tr> <td>16</td> <td>25</td> </tr> </table>	Tel. Port No.	Sta. No. 2-digit	01	10	02	11	03	12	04	13	05	14	06	15	f	f	16	25	Station Numbers (10~59)
Tel. Port No.	Sta. No. 2-digit																				
01	10																				
02	11																				
03	12																				
04	13																				
05	14																				
06	15																				
f	f																				
16	25																				
07	Voice Mail/SLT Selection	No	No, Yes																		
08	Distinctive Ringing Tone to Telephone Selection	Low	Low, Medium, High																		
09	3-Minute Alarm Selection	No	No, Yes																		
10	HFU Selection	No	No, Yes																		
11	Headset Connection Selection	No	No, Yes																		
12	Prime Line Assignment	Non	Non, TK1, TK2, TK3, TK4, TK5, TK6, TK7, TK8																		
13	Attendant Group Selection	Attendant 1	Attendant 1 Attendant 2																		
14	Voice Call Block Selection	No = Voice/Tone Call	No, Yes No = Voice/Tone Call Yes = Tone Only																		
15	CO/PBX Ring Assignment (Day Mode)	<p>Telephones connected to Port Nos. 01 and 02 ring on all incoming CO/PBX calls.</p> <p>Telephones connected to Port Nos. 03~16 do not ring on any incoming CO/PBX calls.</p>	CO/PBX Trunk No. (1~8)																		

TELEPHONE MODE LK4 (continued)

Data No.	Function Name	Default	Programming Value
16	CO/PBX Ring Assignment (Night Mode)	Telephones connected to Port Nos. 01 and 02 ring on all incoming CO/PBX calls. Telephones connected to Port Nos. 03~16 do not ring on any incoming CO/PBX calls.	CO/PBX Trunk No. (1~8)
17	Doorphone Chime Assignment (Day Mode)	Telephones connected to Port Nos. 01 and 02 ring on all Doorphone calls. Telephones connected to Port Nos. 03~16 do not ring on any Doorphone calls.	No, Yes No = No Chime Yes = Chime
18	Doorphone Chime Assignment (Night Mode)	Telephones connected to Port Nos. 01 and 02 ring on all Doorphone calls. Telephones connected to Port Nos. 03~16 do not ring on any Doorphone calls.	No, Yes No = No Chime Yes = Chime
19	Station to Class of Service Feature Assignment (Day Mode)	Port No. 01, 02: Class 0 Port No. 03~16: Class 1	Refer to Memory Block.
20	Station to Class of Service Feature Assignment (Night Mode)	Port No. 01, 02: Class 0 Port No. 03~16: Class 1	Refer to Memory Block.
21	Code Restriction Class Assignment (Day Mode)	Telephones Class 0 Port Nos. 01-16	Class (0~7)
22	Code Restriction Class Assignment (Night Mode)	Telephones Class 0 Port Nos. 01-16	Class (0~7)
23	Trunk Digit Restriction	00 (No Limit)	00, 01 ~ 99
24	Automated Attendant Delay Ring Assignment	Telephones connected to Port Nos. 01 and 02 ring on all incoming CO/PBX calls. Telephones connected to Port Nos. 03~16 do not ring on any incoming CO/PBX calls.	Refer to Memory Block.

5. SPECIAL MODE

- : ROM Version Confirmation
- : System Speed Dial Memory Clear
- : Station Speed Dial Memory Clear
- : System Data Memory Initialize
- : Clock/Calendar

SECTION 4 PROGRAMMING PROCEDURES

Section 4 describes each Memory Block function and programming procedures.

EXAMPLE

PAUSE TIME SELECTION ← System Data Name

System	Data No.
1	06

Mode
Data No.

OPERATION:

1. Go off-line.
2. Enter: Mode
3. Enter: Data No.

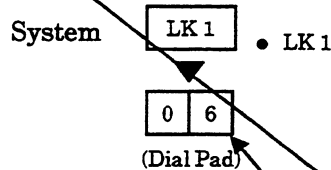

Data No.	Title	Setting Data
0 6	PAUSE	3.0s

TIME DISPLAY		

4. Press the corresponding Dial Pad key to change Setting Data option.
 - To change Pause Time from 3 seconds to 1 second, press Dial Pad key 1.

Dial 0	Dial 1	Dial 2	Dial 3	Dial 4
1 sec.	3 sec.			
Dial 5	Dial 6	Dial 7	Dial 8	Dial 9

Dial Pad key Default

5. Press the TRF key to write the selected data and advance to Memory Block 1-07 (DP Interdigit Time Selection).
6. Press the SPKR key to go back on-line.

■ **Additional Programming**

Mode	Data No.	System Data	
		Required	May Be Required
System (LK 1)	19		
System (LK 1)	24		
System (LK 1)	25		
CO/PBX (LK 3)	01		
CO/PBX (LK 3)	91		

NOTES:

The NOTES section is used to alert the Technician of exceptions to programming.

Status indication LEDs
When Line Key 1 (System Mode) is pressed, the Line Key LED lights.

The OPERATIONS are for guiding the Technician through the procedures for programming a specific Memory Block.

Press these Dial Pad keys in this sequence.

Display

Data assigned to associated Dial Pad keys.

In some instances, additional data must be programmed before or after a specific Memory Block can be programmed. This table contains those additional Memory Blocks.

If additional information is needed on this page, some or all of the notes in the NOTES section continue on the next page.

A brief description of the function(s) of a specific Memory Block.

GENERAL INFORMATION - PAUSE TIME SELECTION

A pause may be inserted between digits dialed on CO/PBX lines. This Memory Block Specifies the length of the pause. A pause is automatically inserted following a "behind a PBX/CTX" Access Code (for example, 9) by programming for PBX line in Memory Block 3-09 (Trunk Type Selection).

HOOKFLASH TIME SELECTION (Multiline Terminal)

System	Data No.
1	01

OPERATION:

1. Go off-line.

2. Enter: Mode System LK 1



3. Enter: Data No. 0 | 1
(Dial Pad)

Data No.	Title	Setting Data
01 :	FLSH	600 ms

TIME	DISPLAY	

NOTES:

1. On a per-Single Line Telephone basis, a hookflash from the SLT can put an existing call on hold or send a hookflash signal on the CO/PBX line.

4. Press the corresponding Dial Pad key to change the Setting Data option.

- To change 600 ms. to 2 sec., press Dial Pad key 9.

Dial 0	Dial 1	Dial 2	Dial 3	Dial 4
60 ms.	100 ms.	140 ms.	200 ms.	400 ms.
Dial 5	Dial 6	Dial 7	Dial 8	Dial 9
600 ms.	800 ms.	1 sec.	1.5 sec.	2 sec.

Dial Pad keys



Default

5. Press the TRF key to write the selected data and advance to Memory Block 1-02 (Hold Recall Timer Selection).

6. Press the SPKR key to go back on-line.

■ Additional Programming

Mode	Data No.	System Data	
		Required	May Be Required
System (LK 1)	34		✓

GENERAL INFORMATION - HOOKFLASH TIME SELECTION (Multiline Terminal)

This Memory Block specifies the length of break time for a hookflash signal (that breaks the DC loop of a CO/PBX line) sent to the CO or PBX when the RECALL key on a Multiline Terminal is pressed, or an SLT generates a hookflash and system is assigned to send the hookflash.

HOLD RECALL TIMER SELECTION (NON-EXCLUSIVE)

System	Data No.
1	02

OPERATION:

1. Go off-line.

2. Enter: Mode System LK 1



3. Enter: Data No. 0 2
(Dial Pad)

Data No.	Title	Setting Data
02 :	HOLDRECL	1.0 m

	TIME	DISPLAY

4. Press the corresponding Dial Pad key to change the Setting Data option.

- To change 1 min. to 2 min, press Dial Pad key 1.

Dial 0	Dial 1	Dial 2	Dial 3	Dial 4
1 min.	2 min.	4 min	No Limit	
Dial 5	Dial 6	Dial 7	Dial 8	Dial 9

Dial Pad keys



Default

5. Press the TRF key to write the selected data and advance to Memory Block 1-03 (Exclusive Hold Recall Timer Selection).

6. Press the SPKR key to go back on-line.

■ Additional Programming

Mode	Data No.	System Data	
		Required	May Be Required
System (LK2)	03		✓

GENERAL INFORMATION - HOLD RECALL TIMER SELECTION

(Non-Exclusive)

This Memory Block specifies the time interval of a non-exclusively held CO/PBX call until a recall tone is generated. If "No Limit" is selected, the hold alarm tone is not generated.

EXCLUSIVE HOLD RECALL TIMER SELECTION

System	Data No.
1	03

OPERATION:

1. Go off-line.

2. Enter: Mode System LK 1

3. Enter: Data No. 0 3
 (Dial Pad)

Data No.	Title	Setting Data
03 :	EXHDRECL	1.0 m

	TIME	DISPLAY

NOTES:

1. Calls put on Non-Exclusive Hold recall using the data selected in Memory Block 1-02 [Hold Recall Timer Selection (Non-Exclusive)].

4. Press the corresponding Dial Pad key to change the Setting Data option.

- To change 1 min. to 2 min., press Dial Pad key 1.

Dial 0	Dial 1	Dial 2	Dial 3	Dial 4
1 min.	2 min.	4 min	No Limit	
Dial 5	Dial 6	Dial 7	Dial 8	Dial 9

Dial Pad keys

Default

5. Press the TRF key to write the selected data and advance to Memory Block 1-04 (Internal/External Paging Access Time Selection).

6. Press the SPKR key to go back on-line.

■ Additional Programming

None

GENERAL INFORMATION - EXCLUSIVE HOLD RECALL TIMER SELECTION

This Memory Block specifies the time interval for Exclusive Hold Recall tone. If "No Limit" is selected, the Exclusive Hold tone is not provided.

INTERNAL/EXTERNAL PAGING ACCESS TIME SELECTION

System	Data No.
1	04

OPERATION:

1. Go off-line.

2. Enter: Mode System LK 1



3. Enter: Data No. 0 4
(Dial Pad)

Data No.	Title	Setting Data
04 :	PAGING	90s

TIME	DISPLAY	

NOTES:

1. There are five types of paging:
 - Internal Zone Paging - 71~73
 - Internal All Zone Paging - 70
 - External Paging - 75
 - All Internal/External Zone Paging - 77
2. There are three selections for length of paging time: 90 sec., 120 sec., and No Limit.

4. Press the corresponding Dial Pad key to change the Setting Data option.

- To change 90 sec. to 120 sec., press Dial Pad key 1.

Dial 0	Dial 1	Dial 2	Dial 3	Dial 4
90 sec.	120 sec	No Limit		
Dial 5	Dial 6	Dial 7	Dial 8	Dial 9

Dial Pad keys



5. Press the TRF key to write the selected data and advance to Memory Block 1-05 (Trunk Queuing Recall Time Selection).
6. Press the SPKR key to go back on-line.

■ Additional Programming

Mode	Data No.	System Data	
		Required	May Be Required
System (LK 1)	29		✓
System (LK 1)	30		✓
Telephone (LK 4)	03		✓

GENERAL INFORMATION - INTERNAL/EXTERNAL PAGING ACCESS TIME SELECTION

This Memory Block programs the time allowed for paging.

TRUNK QUEUING RECALL TIME SELECTION

System	Data No.
1	05

OPERATION:

1. Go off-line.

2. Enter: Mode System LK 1

3. Enter: Data No. 0 5
(Dial Pad)

Data No.	Title	Setting Data
05 :	TRUNK QUE	10s

TIME DISPLAY		

NOTES:

1. When all trunks in a particular Trunk Group are busy, the station user can dial an Access Code to "queue" onto the busy Trunk Group. When a trunk (within that group) becomes idle, the queued station is signaled.

4. Press the corresponding Dial Pad key to change the Setting Data option.

- To change 10 sec. to 30 sec., press Dial Pad key 2.

Dial 0	Dial 1	Dial 2	Dial 3	Dial 4
10 sec.	20 sec	30 sec.	60 sec.	
Dial 5	Dial 6	Dial 7	Dial 8	Dial 9

Dial Pad keys

Default

5. Press the TRF key to write the selected data and advance to Memory Block 1-06 (Pause Time Selection).

6. Press the SPKR key to go back on-line.

■ Additional Programming

None

GENERAL INFORMATION - TRUNK QUEUING RECALL TIME SELECTION

This Memory Block determines the time that an outgoing CO/PBX line rings at the station where the queue was set, before the queue is automatically canceled.

PAUSE TIME SELECTION

System	Data No.
1	06

OPERATION:

1. Go off-line.

2. Enter: Mode System LK 1



3. Enter: Data No. 0 6
(Dial Pad)

Data No.	Title	Setting Data
06 :	PAUSE	3.0s

TIME DISPLAY		

4. Press the corresponding Dial Pad key to change the Setting Data option.

- To change 3 sec. to 1 sec., press Dial Pad key 0.

Dial 0	Dial 1	Dial 2	Dial 3	Dial 4
1 sec.	3 sec.			
Dial 5	Dial 6	Dial 7	Dial 8	Dial 9

Dial Pad keys

Default

5. Press the TRF key to write the selected data and advance to Memory Block 1-07 (DP Interdigit Time Selection).

6. Press the SPKR key to go back on-line.

■ Additional Programming

Mode	Data No.	System Data	
		Required	May Be Required
System (LK1)	31		✓
CO/PBX (LK 3)	09		✓

NOTES:

1. A pause is automatically inserted following a PBX Access Code (for example, 9) by programming CO/PBX lines as PBX in Memory Block 3-09 (Trunk Type Selection).
2. Pauses can be stored as part of System and Station Speed Dial buffers when needed.

GENERAL INFORMATION - PAUSE TIME SELECTION

A pause may be inserted between digits dialed on CO/PBX lines. This Memory Block Specifies the length of the pause. A pause is automatically inserted following a "behind a PBX/CTX" Access Code (for example, 9) by programming for PBX line in Memory Block 3-09 (Trunk Type Selection).

DP INTERDIGIT TIME SELECTION

System	Data No.
1	07

OPERATION:

1. Go off-line.

2. Enter: Mode System LK 1



3. Enter: Data No. 0 7
(Dial Pad)

Data No.	Title	Setting Data
07 :	DP INTER	B

	TIME DISPLAY	

NOTES:

1. This Memory Block is used when CO/PBX lines are assigned to send Dial Pulse signaling in Memory Block 3-10 [CO Line Selection (Installed, DP, DTMF)].

4. Press the corresponding Dial Pad key to change the Setting Data option.

- To change Pattern B to Pattern A, press Dial Pad key 0.

Dial 0	Dial 1	Dial 2	Dial 3	Dial 4
Pattern A	Pattern B			
Dial 5	Dial 6	Dial 7	Dial 8	Dial 9

Dial Pad keys Default

5. Press the TRF key to write the selected data and advance to Memory Block 1-08 [Receiver (PBR) Release Timer Selection].

6. Press the SPKR key to go back on-line.

Data \ DP Dial	10 pps.	20 pps.
	Pattern A	650 ms.
Pattern B	800 ms.	800 ms.

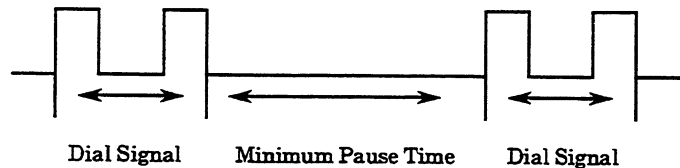

■ Additional Programming

Mode	Data No.	System Data	
		Required	May Be Required
CO/PBX (LK3)	10		✓

GENERAL INFORMATION - DP INTERDIGIT TIME SELECTION

The DP Interdigit Time is the minimum pause time interval between Dial Pulse dialing. Either Pattern A or Pattern B can be selected.

RECEIVER (PBR) RELEASE TIMER SELECTION

OPERATION:

System	Data No.
1	08

1. Go off-line.

2. Enter: Mode System LK 1

3. Enter: Data No. 0 8
(Dial Pad)

Data No.	Title	Setting Data
0 8 :	PBR RLS	10s

TIME DISPLAY		

Specified Time
(Default = 10 sec.)

Seven sec.

(MB 1, 8, and 10)

Seven sec.

Ten sec.

Off-Hook



Dial tone is sent (PBR connected).

9

Dial the first digit.

7

The second digit.

5

The third digit.

3

If the last digit is dialed, PBR is disconnected.

4. Press the corresponding Dial Pad key to change the Setting Data option.

- To change 10 sec. to 20 sec., press Dial Pad key 2.

Dial 0	Dial 1	Dial 2	Dial 3	Dial 4
5 sec.	10 sec.	20 sec.	30 sec.	50 sec.
Dial 5	Dial 6	Dial 7	Dial 8	Dial 9
60 sec.				

Dial Pad keys



Default

5. Press the TRF key to write the selected data and advance to Memory Block 1-09 (Doorphone Display Time Selection).

6. Press the SPKR key to go back on-line.

■ Additional Programming

Mode	Data No.	System Data	
		Required	May Be Required
Telephone (LK 4)	01		✓
Telephone (LK 4)	05		✓

GENERAL INFORMATION - RECEIVER (PBR) RELEASE TIMER SELECTION

This Memory Block specifies the time between each digit dialed during which a receiver circuit is connected when a DTMF type Single Line Telephone user goes off-hook and dials digits.

DOORPHONE DISPLAY TIME SELECTION

System	Data No.
1	09

OPERATION:

1. Go off-line.

2. Enter: Mode System LK 1



3. Enter: Data No. 0 9
(Dial Pad)

Data No.	Title	Setting Data
09	DPH DSP	10s

TIME	DISPLAY	

4. Press the corresponding Dial Pad key to change the Setting Data option.

- To change 10 sec. to 30 sec., press Dial Pad key 1.

Dial 0	Dial 1	Dial 2	Dial 3	Dial 4
10 sec.	30 sec.	60 sec.	90 sec.	
Dial 5	Dial 6	Dial 7	Dial 8	Dial 9

Dial Pad keys

Default

5. Press the TRF key to write the selected data and advance to Memory Block 1-10 (CO Transfer Recall Timer Selection).

6. Press the SPKR key to go back on-line.

■ Additional Programming

Mode	Data No.	System Data	
		Required	May Be Required
System (LK 1)	33	✓	
System (LK 1)	45		✓
Telephone (LK 4)	17		✓
Telephone (LK 4)	18		✓

GENERAL INFORMATION - DOORPHONE DISPLAY TIME SELECTION

This Memory Block assigns the time the Multiline Terminal displays an incoming Doorphone call indication.

CO TRANSFER RECALL TIMER SELECTION

System	Data No.
1	10

OPERATION:

1. Go off-line.

2. Enter: Mode System LK 1



3. Enter: Data No. 1 | 0
(Dial Pad)

Data No.	Title	Setting Data
1 0 :	TRF RECL	60 s

TIME	DISPLAY	

NOTES:

1. Only CO/PBX line calls can be ring transferred.

4. Press the corresponding Dial Pad key to change the Setting Data option.

- To change 60 sec. to 120 sec., press Dial Pad key 2.

Dial 0	Dial 1	Dial 2	Dial 3	Dial 4
30 sec.	60 sec.	120 sec.	240 sec.	
Dial 5	Dial 6	Dial 7	Dial 8	Dial 9

Dial Pad keys



Default

5. Press the TRF key to write the selected data and advance to Memory Block 1-11 (Automatic Callback Time Selection).

6. Press the SPKR key to go back on-line.

■ Additional Programming

Mode	Data No.	System Data	
		Required	May Be Required
System (LK 1)	25		✓
Telephone (LK 4)	15		✓
Telephone (LK 4)	16		✓

GENERAL INFORMATION - CO RING TRANSFER RECALL TIMER SELECTION

This Memory Block specifies the time from CO/PBX line ringing tone transfer until a recall tone is generated to the originating telephone if the call is not answered.

AUTOMATIC CALLBACK TIME SELECTION

System	Data No.
1	11

OPERATION:

1. Go off-line.

2. Enter: Mode System LK 1



3. Enter: Data No. 1 1
(Dial Pad)

Data No.	Title	Setting Data
1 1 :	CALLBACK	00 m

TIME	DISP LAY	

4. Press the corresponding Dial Pad key to change the Setting Data option.

- To change No Limit to 30 min., press Dial Pad key 0.

Dial 0	Dial 1	Dial 2	Dial 3	Dial 4
30 min.	60 min.	90 min.	(0) (No Limit)	
Dial 5	Dial 6	Dial 7	Dial 8	Dial 9

Dial Pad keys

Default

5. Press the TRF key to write the selected data and advance to Memory Block 1-12 (Automatic Redial Time Selection).

6. Press the SPKR key to go back on-line.

■ Additional Programming

None

GENERAL INFORMATION - AUTOMATIC CALLBACK TIME SELECTION

This Memory Block determines the time allowed for an automatic callback to occur before the request is automatically canceled.

AUTOMATIC REDIAL TIME SELECTION

System	Data No.
1	12

OPERATION:

1. Go off-line.

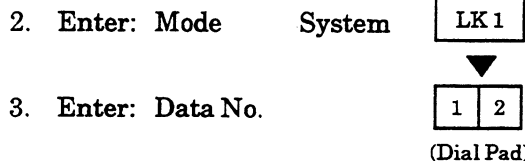

Data No.	Title	Setting Data
1 2 :	REDIAL	15/60

TIME	DISPLAY	

4. Press the corresponding Dial Pad key to change the Setting Data option.

- To change 60 sec./90 sec. to 30 sec./30 sec., press Dial Pad key 3.

Dial 0	Dial 1	Dial 2	Dial 3	Dial 4
15/60 sec.	15/120 sec.	15/180 sec.	30/120 sec.	
Dial 5	Dial 6	Dial 7	Dial 8	Dial 9

Dial Pad keys



Default

5. Press the TRF key to write the selected data and advance to Memory Block 1-13 (Bounce Protect Time Selection).

6. Press the SPKR key to go back on-line.

■ Additional Programming

None

NOTES:

1. Definitions:

Calling Time: The time that the system automatically rings the busy CO/PBX number. After the specified time limit, the ringing stops.

Call Waiting Time: The time the system waits before redialing the called party's station.

Call Attempts: The number of times the system redials the busy CO/PBX number.

2. Setting Data:

Dial No.	Calling Time	Call Waiting Time	Call Attempts
0	15 sec.	60 sec.	5
1	15 sec.	120 sec.	5
2	15 sec.	180 sec.	5
3	30 sec.	120 sec.	5

GENERAL INFORMATION - AUTOMATIC REDIAL TIME SELECTION

When a called party is busy, the station user dials an Access Code and restores the handset. As programmed in this Memory Block, the system automatically redials the busy CO/PBX number and waits the specified calling time. After the specified number of call attempts with no answer, the system stops dialing.

BOUNCE PROTECT TIME SELECTION

System	Data No.
1	13

OPERATION:

1. Go off-line.

2. Enter: Mode System LK 1

3. Enter: Data No. 1 3
(Dial Pad)

Data No.	Title	Setting Data
1 3 :	BNCE	300 ms.

TIME		DISPLAY

4. Press the corresponding Dial Pad key to change the Setting Data option.

- To change 300 ms. to 900 ms., press Dial Pad key 3.

Dial 0	Dial 1	Dial 2	Dial 3	Dial 4
0 ms.	300 ms.	600 ms.	900 ms.	
Dial 5	Dial 6	Dial 7	Dial 8	Dial 9

Dial Pad keys

Default

5. Press the TRF key to write the selected data and advance to Memory Block 1-14 (Hookflash Start Time Selection).

6. Press the SPKR key to go back on-line.

■ Additional Programming

Mode	Data No.	System Data	
		Required	May Be Required
Telephone (LK 4)	01		✓

GENERAL INFORMATION - BOUNCE PROTECT TIME SELECTION

This Memory Block specifies the necessary duration of a hookflash before it can be detected as a valid hookflash from a Single Line Telephone or Voice Mail port.

HOOKFLASH START TIME SELECTION

System	Data No.
1	14

OPERATION:

1. Go off-line.

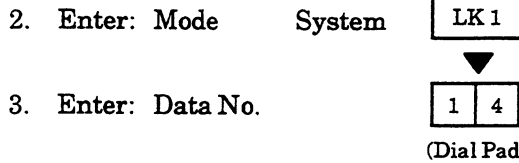

NOTES:

1. A hookflash during a CO/PBX call places the line on hold or sends a hookflash to the CO/PBX.
2. When a hookflash is 0.1 seconds or less, or 2.3 seconds or more, it is not considered to be a hookflash.

Data No.	Title	Setting Data
1 4 :	FLSH ST	300 ms.

TIME	DISPLAY	

4. Press the corresponding Dial Pad key to change the Setting Data option.
- To change 300 ms. to 450 ms., press Dial Pad key 5.

Dial 0	Dial 1	Dial 2	Dial 3	Dial 4
100 ms.	150 ms.	200 ms.	300 ms.	350 ms.
Dial 5	Dial 6	Dial 7	Dial 8	Dial 9
450 ms.	550 ms.	650 ms.	750 ms.	850 ms.

Dial Pad keys

Default

5. Press the TRF key to write the selected data and advance to Memory Block 1-15 (Hookflash End Time Selection).
6. Press the SPKR key to go back on-line.

■ Additional Programming

Mode	Data No.	System Data	
		Required	May Be Required
System (LK 1)	15		✓

GENERAL INFORMATION - HOOKFLASH START TIME SELECTION

This Memory Block specifies the start of a hookflash duration from a Single Line Telephone to receive a dial tone. The duration, plus the duration specified in the Hookflash End Time Memory Block, specifies the length of a valid hookflash.

HOOKFLASH END TIME SELECTION

System	Data No.
1	15

OPERATION:

1. Go off-line.

2. Enter: Mode System LK 1



3. Enter: Data No. 1 5
(Dial Pad)

Data No.	Title	Setting Data
1 5 :	FLSH END	700ms

TIME		DISPLAY

4. Press the corresponding Dial Pad key to change the Setting Data option.

- To change 700 ms. to 400 ms., press Dial Pad key 3.

Dial 0	Dial 1	Dial 2	Dial 3	Dial 4
HST + 0	HST + 100ms.	HST + 200ms.	HST + 400ms.	HST + 500ms.
Dial 5	Dial 6	Dial 7	Dial 8	Dial 9
HST + 700ms	HST + 900ms.	HST + 1100ms.	HST + 1300ms.	HST + 1500ms.

Dial Pad keys Default

HST = Hookflash Start Time

5. Press the TRF key to write the selected data and advance to Memory Block 1-16 (Call Forward Busy/No Answer Timer Selection).

6. Press the SPKR key to go back on-line.

■ Additional Programming

Mode	Data No.	System Data	
		Required	May Be Required
System (LK 1)	14	✓	

GENERAL INFORMATION - HOOKFLASH END TIME SELECTION

This Memory Block specifies a maximum duration from a Single Line Telephone to receive a dial tone.

CALL FORWARD BUSY/NO ANSWER TIMER SELECTION

System	Data No.
1	16

OPERATION:

1. Go off-line.

2. Enter: Mode System LK 1



3. Enter: Data No. 1 | 6
(Dial Pad)

Data No.	Title	Setting Data
1 6 :	FWD NOANS	10 s
TIME	DISPLAY	

4. Press the corresponding Dial Pad key to change the Setting Data option.

- To change 10 sec. to 15 sec., press Dial Pad key 1.

Dial 0	Dial 1	Dial 2	Dial 3	Dial 4
10 sec.	15 sec.	20 sec.	25 sec.	30 sec.
Dial 5	Dial 6	Dial 7	Dial 8	Dial 9
60 sec.				

Dial Pad keys



Default

5. Press the TRF key to write the selected data and advance to Memory Block 1-17 (Trunk-to-Trunk Transfer Automatic Disconnect Time Selection).

6. Press the SPKR key to go back on-line.

■ Additional Programming

Mode	Data No.	System Data	
		Required	May Be Required
System (LK1)	55		✓
Telephone (LK 4)	19		✓
Telephone (LK 4)	20		✓

GENERAL INFORMATION - CALL FORWARD BUSY/NO ANSWER TIMER SELECTION

This Memory Block specifies the time before incoming internal calls and CO/PBX transferred calls are forwarded to another station number when the called party does not answer.

TRUNK-TO-TRUNK TRANSFER AUTOMATIC DISCONNECT TIME SELECTION

System	Data No.
1	17

OPERATION:

1. Go off-line.

2. Enter: Mode System LK 1



3. Enter: Data No. 1 7
(Dial Pad)

Data No.	Title	Setting Data
1 7 :	AUTO DIS	1 H

TIME	DISPLAY	

4. Press the corresponding Dial Pad key to change the Setting Data option.

- To change 1 hr. to 3 hr., press Dial Pad key 3.

Dial 0	Dial 1	Dial 2	Dial 3	Dial 4
30 min.	1 hr.	2 hr.	3 hr.	
Dial 5	Dial 6	Dial 7	Dial 8	Dial 9

Dial Pad keys

Default

5. Press the TRF key to write the selected data and advance to Memory Block 1-18 (Elapsed Call and SMDR Start Timer Selection).

6. Press the SPKR key to go back on-line.

■ Additional Programming

Mode	Data No.	System Data	
		Required	May Be Required
System (LK 1)	55		✓
Telephone (LK 4)	19		✓
Telephone (LK 4)	20		✓

GENERAL INFORMATION - TRUNK-TO-TRUNK TRANSFER AUTOMATIC DISCONNECT TIME SELECTION

This Memory Block specifies the time after which a Trunk-to-Trunk transfer is disconnected automatically.

ELAPSED CALL AND SMDR START TIMER SELECTION

System	Data No.
1	18

OPERATION:

1. Go off-line.

2. Enter: Mode System LK 1



3. Enter: Data No. 1 8
(Dial Pad)

Data No.	Title	Setting Data
1 8 :	CALL START	10 s
TIME	DISPLAY	

4. Press the corresponding Dial Pad key to change the Setting Data option.

- To change 10 sec. to 20 sec., press Dial Pad key 1.

Dial 0	Dial 1	Dial 2	Dial 3	Dial 4
10 sec.	20 sec	30 sec.		
Dial 5	Dial 6	Dial 7	Dial 8	Dial 9

Dial Pad keys



Default

5. Press the TRF key to write the selected data and advance to Memory Block 1-19 (Disconnect Time Selection).

6. Press the SPKR key to go back on-line.

■ **Additional Programming**

None

GENERAL INFORMATION - ELAPSED CALL AND SMDR START TIMER SELECTION

This Memory Block specifies the time after dialing before the call duration time is displayed on a Multiline Terminal.

DISCONNECT TIME SELECTION

System	Data No.
1	19

OPERATION:

1. Go off-line.

2. Enter: Mode System LK 1

3. Enter: Data No. 1 9
(Dial Pad)

Data No.	Title	Setting Data
19 :	DIS TM	1.5 s

TIME DISPLAY		

4. Press the corresponding Dial Pad key to change the Setting Data option.

- To change 1.0 sec. to 3.0 sec., press Dial Pad key 7.

Dial 0	Dial 1	Dial 2	Dial 3	Dial 4
0.3 sec.	0.5 sec.	0.7 sec.	1.0 sec.	1.5 sec.
Dial 5	Dial 6	Dial 7	Dial 8	Dial 9
2.0 sec.	2.5 sec.	3.0 sec.	3.5 sec.	4.0 sec.

Dial Pad keys Default

5. Press the TRF key to write the selected data and advance to Memory Block 1-20 (Automatic Release Disconnection Signal Detection Time Selection).

6. Press the SPKR key to go back on-line.

- Additional Programming
None

NOTES:

1. If a call originating on a CO/PBX line is interrupted or dropped while in progress, the seized line must be disconnected and cleared before it can be accessed again.
2. The system must be idle before this data is written into memory.
3. The Drop Key timer is also affected by this Memory Block.

GENERAL INFORMATION - DISCONNECT TIME SELECTION

This Memory Block specifies the minimum time before a disconnected CO/PBX line can be accessed again.

AUTOMATIC RELEASE DISCONNECTION SIGNAL DETECTION TIME SELECTION

System	Data No.
1	20

OPERATION:

1. Go off-line.

2. Enter: Mode System LK 1



3. Enter: Data No. 2 | 0
(Dial Pad)

Data No.	Title	Setting Data
2 0 :	ARDT	350 ms

TIME	DISPLAY	

4. Press the corresponding Dial Pad key to change the Setting Data option.

- To change 350 ms. to 300 ms., press Dial Pad key 6.

Dial 0	Dial 1	Dial 2	Dial 3	Dial 4
5 sec.	50 ms.	100 ms.	150 ms.	200 ms.
Dial 5	Dial 6	Dial 7	Dial 8	Dial 9
250 ms.	300 ms.	350 ms.	400 ms.	500 ms.

Dial Pad keys



Default

5. Press the TRF key to write the selected data and advance to Memory Block 1-21 (Voice/Tone Signal Selection).

6. Press the SPKR key to go back on-line.

■ Additional Programming

None

GENERAL INFORMATION - AUTOMATIC RELEASE DISCONNECTION SIGNAL DETECTION TIME SELECTION

This Memory Block specifies the signal detection time for release of a CO/PBX line when a disconnect signal is received from the distant CO/PBX.

VOICE/TONE SIGNAL SELECTION

System	Data No.
1	21

OPERATION:

1. Go off-line.

2. Enter: Mode System LK 1



3. Enter: Data No. 2 1
(Dial Pad)

Data No.	Title	Setting Data
2 1 :	CALL	VOICE

TIME	DISPLAY	

4. Press the corresponding Dial Pad key to change the Setting Data option.

- To change Voice to Tone, press Dial Pad key 0.

Dial 0	Dial 1	Dial 2	Dial 3	Dial 4
Tone	Voice			
Dial 5	Dial 6	Dial 7	Dial 8	Dial 9

Dial Pad keys Default

5. Press the TRF key to write the selected data and advance to Memory Block 1-22 (BGM Selection).

6. Press the SPKR key to go back on-line.

■ Additional Programming

Mode	Data No.	System Data	
		Required	May Be Required
Telephone (LK 4)	14		✓

NOTES:

1. Switching from voice to signal tone or from signal tone to voice can be accomplished by dialing a station number, then dialing 1.
2. If signal tone is programmed in this Memory Block, the called party cannot answer handsfree unless the originator of the call switches to voice by dialing 1.
3. Memory Block 4-14 (Voice Call Block Selection) can be used to restrict voice signaling.
4. Voice Mail ports can send a tone signal only.

GENERAL INFORMATION - VOICE/TONE SIGNAL SELECTION

This Memory Block determines if signal tone or voice is used first for an internal call.

BGM SELECTION

System	Data No.
1	22

OPERATION:

1. Go off-line.

2. Enter: Mode System LK 1



3. Enter: Data No. 2 2
(Dial Pad)

Data No.	Title	Setting Data
2 2 :	BGM	NO

TIME	DISPLAY	

4. Press the corresponding Dial Pad key to change the Setting Data option.

- To change No to Speaker, press Dial Pad key 2.

Dial 0	Dial 1	Dial 2	Dial 3	Dial 4
No	Tel	SP	Tel and SP	
Dial 5	Dial 6	Dial 7	Dial 8	Dial 9

Dial Pad keys



Default

Tel = Multiline Terminal

SP = External Speaker

5. Press the TRF key to write the selected data and advance to Memory Block 1-23 (System Speed Dial Override Selection).

6. Press the SPKR key to go back on-line.

■ Additional Programming

Mode	Data No.	System Data	
		Required	May Be Required
System (LK 1)	30		✓

GENERAL INFORMATION - BGM SELECTION

This Memory Block specifies if the tone from an external music source is provided for background music to station speakers and/or external paging speaker.

SYSTEM SPEED DIAL OVERRIDE SELECTION

System	Data No.
1	23

OPERATION:

1. Go off-line.

2. Enter: Mode System LK 1



3. Enter: Data No. 2 | 3
(Dial Pad)

Data No.	Title	Setting Data
2 3 :	SPDOVR	NO

TIME	DISPLAY	

NOTES:

1. System Speed Dial buffers 20~59 cannot be programmed to override Code Restrictions.

4. Press the corresponding Dial Pad key to change the Setting Data option.

- To change No to Yes, press Dial Pad key 1.

Dial 0	Dial 1	Dial 2	Dial 3	Dial 4
No	Yes			
Dial 5	Dial 6	Dial 7	Dial 8	Dial 9

Dial Pad keys



Default

Yes = System Speed Dial buffers 60~99 for feature class 0~6 override code restrictions.

No = System Speed Dial buffers 60~99 for feature class 0~6 cannot override code restrictions.

5. Press the TRF key to write the selected data and advance to Memory Block 1-24 (System Speed Dial Display Station Selection).

6. Press the SPKR key to go back on-line.

■ Additional Programming

Mode	Data No.	System Data	
		Required	May Be Required
System (LK 1)	24		✓
Telephone (LK 4)	19		✓
Telephone (LK 4)	20		✓

GENERAL INFORMATION - SYSTEM SPEED DIAL OVERRIDE SELECTION

This Memory Block allows or denies the override of Code Restrictions of System Speed Dial 60~99.

SYSTEM SPEED DIAL DISPLAY STATION SELECTION

System	Data No.
1	24

OPERATION:

1. Go off-line.

2. Enter: Mode System LK 1



3. Enter: Data No. 2 | 4
(Dial Pad)

Data No.	Title	Setting Data
2 4 :	SPD DSP	ATT

TIME	DISPLAY	

4. Press the corresponding Dial Pad key to change the Setting Data option.

- To change Attendant Position (ports 01 and 02) to All Multiline Terminals, press Dial Pad key 1.

Dial 0	Dial 1	Dial 2	Dial 3	Dial 4
Att	All			
Dial 5	Dial 6	Dial 7	Dial 8	Dial 9

Dial Pad keys



Default

Att: Attendant Positions (ports 01 and 02)

All: All Multiline Terminals

5. Press the TRF key to write the selected data and advance to Memory Block 1-25 (Ring Transfer Selection).

6. Press the SPKR key to go back on-line.

■ Additional Programming

Mode	Data No.	System Data	
		Required	May Be Required
System (LK 1)	55		✓
Telephone (LK 4)	19		✓
Telephone (LK 4)	20		✓

GENERAL INFORMATION - SYSTEM SPEED DIAL DISPLAY STATION SELECTION

This Memory Block specifies the terminal that can display the telephone number of a System Speed Dial buffer.

RING TRANSFER SELECTION

System	Data No.
1	25

OPERATION:

1. Go off-line.

2. Enter: Mode System LK 1

3. Enter: Data No. 2 | 5
(Dial Pad)

Data No.	Title	Setting Data
2 5 :	RING TRF	YS

TIME	DISPLAY	

NOTES:

1. All ports are affected by this Memory Block, including Voice Mail ports.

4. Press the corresponding Dial Pad key to change the Setting Data option.

- To change Yes to No, press Dial Pad key 0.

Dial 0	Dial 1	Dial 2	Dial 3	Dial 4
No	Yes			
Dial 5	Dial 6	Dial 7	Dial 8	Dial 9

Dial Pad keys Default

5. Press the TRF key to write the selected data and advance to Memory Block 1-26 [Time Display (12h/24h) Selection].

6. Press the SPKR key to go back on-line.

■ **Additional Programming**

None

GENERAL INFORMATION - RING TRANSFER SELECTION

This Memory Block allows or denies the use of the Ring Transfer feature.

TIME DISPLAY (12h/24h) SELECTION

System	Data No.
1	26

OPERATION:

1. Go off-line.

2. Enter: Mode System LK 1



3. Enter: Data No. 2 | 6
(Dial Pad)

Data No.	Title	Setting Data
2 6 :	HOUR DISP	12H

TIME DISPLAY		

4. Press the corresponding Dial Pad key to change the Setting Data option.

- To change 12-hr. to 24-hr., press Dial Pad key 1.

Dial 1	Dial 1	Dial 2	Dial 3	Dial 4
Dial 2	24 hr.			
Dial 5	Dial 6	Dial 7	Dial 8	Dial 9

Dial Pad keys



Default

5. Press the TRF key to write the selected data and advance to Memory Block 1-27 (Day/Night Mode Switching Time Assignment).

6. Press the SPKR key to go back on-line.

■ **Additional Programming**

None

GENERAL INFORMATION - TIME DISPLAY (12h/24h) SELECTION

This Memory Block specifies either a 12-hour (12:00 AM - 11:59 PM) or 24-hour (00:00 - 23:59) time display.

DAY/NIGHT MODE SWITCHING TIME ASSIGNMENT

System	Data No.
1	27

OPERATION:

1. Go off-line.

2. Enter: Mode System LK 1

3. Enter: Data No. 2 | 7
(Dial Pad)

Data No.	Night Switch	Day Switch
2 7 : NT	:	:
TIME DISPLAY		

4. Enter data by using the Dial Pad.

- Example: To switch time, enter 08:00 and 20:00.

← * , # → : To move cursor.

Dial pad 0 ~ 9 : To enter data.

HOLD key : To clear all data when cursor is at Data No. position.

Default	Not Specified
---------	---------------

5. Press the TRF key to write the selected data and advance to Memory Block 1-28 (Receiving Volume Selection).
6. Press the SPKR key to go back on-line.

- Additional Programming
None

NOTES:

1. The system can be placed into Day or Night Mode anytime from a terminal assigned this feature.
2. The start times of Day Mode and Night Mode can be specified in System Programming to automatically switch modes at the specified times.
3. A start time for Day Mode only or Night Mode only cannot be programmed.
4. Day Mode and Night Mode should not be programmed to have the same start time.
5. The time is entered by the 24-hour time system (00:00 ~ 23:59) only.
6. The first input represents when Night Mode begins. The second input represents the beginning of Day Mode.

GENERAL INFORMATION - DAY/NIGHT MODE SWITCHING TIME ASSIGNMENT

This Memory Block allows automatic switching of the system between Day Mode and Night Mode.

RECEIVING VOLUME SELECTION

System	Data No.
1	28

OPERATION:

1. Go off-line.

2. Enter: Mode System LK 1



3. Enter: Data No. 2 | 8
(Dial Pad)

Data No.	Title	Setting Data
2 8 :	RCV	DOWN

TIME	DISPLAY	

4. Press the corresponding Dial Pad key to change the Setting Data option.

- To change Down to Up, press Dial Pad key 1.

Dial 0	Dial 1	Dial 2	Dial 3	Dial 4
Down	Up			
Dial 5	Dial 6	Dial 7	Dial 8	Dial 9

Dial Pad keys



Default

Down = Return to normal
Up = Volume remains up

5. Press the TRF key to write the selected data and advance to Memory Block 1-29 (Barge-In Alert Tone Assignment).

6. Press the SPKR key to go back on-line.

■ Additional Programming

None

GENERAL INFORMATION - RECEIVING VOLUME SELECTION

This Memory Block specifies whether the receiving volume is returned to normal (Down) or remains Up on a call after the handset is returned to the cradle.

BARGE-IN ALERT TONE ASSIGNMENT

System	Data No.
1	29

OPERATION:

1. Go off-line.

2. Enter: Mode System

LK 1

3. Enter: Data No.

2	9
---	---

(Dial Pad)

NOTES:

1. Barge-In applies only to CO/PBX line calls.

Data No.	Title	Setting Data
2 9 :	ALERT TONE	YS

	TIME	DISPLAY

4. Press the corresponding Dial Pad key to change the Setting Data option.
- To change No to Yes, press Dial Pad key 1.

Dial 0	Dial 1	Dial 2	Dial 3	Dial 4
No	Yes			
Dial 5	Dial 6	Dial 7	Dial 8	Dial 9

Dial Pad keys Default

No = Alert Tone Deny
Yes = Alert Tone Allow

5. Press the TRF key to write the selected data and advance to Memory Block 1-30 (External Speaker Connection Selection).
6. Press the SPKR key to go back on-line.

- Additional Programming
None

GENERAL INFORMATION - BARGE-IN ALERT TONE ASSIGNMENT

This Memory Block specifies whether the Barge-In Alert Tone is allowed or denied.

EXTERNAL SPEAKER CONNECTION SELECTION

System	Data No.
1	30

OPERATION:

1. Go off-line.

2. Enter: Mode System LK 1



3. Enter: Data No. 3 | 0
(Dial Pad)

Data No.	Title	Setting Data
3 0 :	ESP CONN	YS

TIME	DISPLAY	

4. Press the corresponding Dial Pad key to change the Setting Data option.

- To change Yes to No, press Dial Pad key 0.

Dial 0	Dial 1	Dial 2	Dial 3	Dial 4
No	Yes			
Dial 5	Dial 6	Dial 7	Dial 8	Dial 9

Dial Pad keys

Default

Yes = External Speaker connected

No = External Speaker not connected

5. Press the TRF key to write the selected data and advance to Memory Block 1-31 (PBX/CTX Access Code Assignment).

6. Press the SPKR key to go back on-line.

■ **Additional Programming**

None

GENERAL INFORMATION - EXTERNAL SPEAKER CONNECTION SELECTION

This Memory Block specifies whether or not an external speaker is connected to the system.

PBX/CTX ACCESS CODE ASSIGNMENT

System	Data No.
1	31

OPERATION:

1. Go off-line.

2. Enter: Mode System LK 1

3. Enter: Data No. 3 1
(Dial Pad)

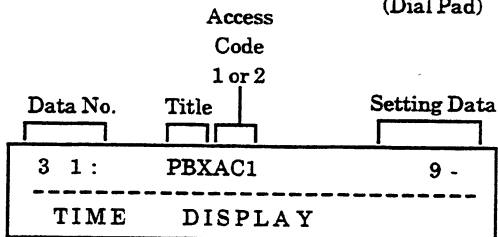

4. Enter the data by using the Dial Pad.

Example: To program, dial: 9, LNR/SPD, 2, 2, LNR/SPD.

(The LNR/SPD key is used to insert a pause.)

Default	Access Code 1 = 9 Access Code 2 = Vacant
---------	---

← * , # → : To move cursor.

Dial Pad 0 ~ 9 : To enter data.

LNR/SPD key : To insert a pause.

HOLD key : To clear all data.

5. Press the TRF key to write the selected data and advance to the next PBX/CTX line Access Code. Press the TRF key to write the data and to advance to Memory Block 1-32 (Private Line Assignment).

6. Press the SPKR key to go back on-line.

NOTES:

1. Features such as Code Restriction do not operate properly unless an Access Code indicating "behind a PBX/CTX line" is specified.
2. An automatic pause is not inserted in the number of an outgoing call on a CO line.
3. Up to three numeric characters and three pauses can be specified.
4. A pause cannot be inserted as the first digit.
5. Only PBX-type lines are affected by this Memory Block.

■ Additional Programming

Mode	Data No.	System Data	
		Required	May Be Required
CO/PBX (LK 3)	09		√

GENERAL INFORMATION - PBX/CTX ACCESS CODE ASSIGNMENT

This Memory Block specifies a PBX/CTX line Access Code together with pauses for PBX/CTX line outgoing calls from a station of the system when connected behind a PBX.

PRIVATE LINE ASSIGNMENT

System	Data No.
1	32

OPERATION:

1. Go off-line.

2. Enter: Mode System LK 1



3. Enter: Data No. 3 2
(Dial Pad)

Combination

Data No.	Title	No. (1~2)	CO No. (01 ~ 08)	Tel Port No. (01 ~ 16)
3 2 :	P	1	C	T T

TIME DISPLAY				

4. Use the Dial Pad key to enter data.

- Example: CO line 5 is assigned as Private Line for Tel. Port No. 11.

← * , # → : To move cursor.

Dial pad 0 ~ 9 : To enter CO No.

HOLD key : To clear all data when cursor is at CO No.

Default	Not Specified
---------	---------------

- Press the TRF key to write the data and advance to the second Private Line Assignment.
- After entering the desired data, press the TRF key to write that data and advance to Memory Block 1-33 (Doorphone Connection Selection).
- Press the SPKR key to go back on-line.

NOTES:

- A maximum of two Private Lines can be assigned.
- The two Private Lines can be assigned in any combination (refer to chart below).
- Private Lines can be assigned to Single Line Telephones.

Combination Chart

Private Line 1	Tel #	
	Tel #	
Private Line 2	Tel #	
	Tel #	

■ Additional Programming

Mode	Data No.	System Data	
		Required	May Be Required
Tenant (LK 2)	01		✓

GENERAL INFORMATION - PRIVATE LINE ASSIGNMENT

This Memory Block assigns an outside line for use as a Private Line. The Private Line cannot be seized by any other telephone, and no LED indication is provided to other terminals.

DOORPHONE CONNECTION SELECTION

System	Data No.
1	33

OPERATION:

1. Go off-line.

2. Enter: Mode System LK 1



3. Enter: Data No. 3 3
(Dial Pad)

Data No.	Doorphone No. 1 or 2	Setting Data
3 3 :	DPH 1 CONN	YS

TIME	DISPLAY	

4. Press the corresponding Dial Pad key to change the Setting Data option.

- To change Yes to No, press Dial Pad key 0.

Dial 0	Dial 1	Dial 2	Dial 3	Dial 4
No	Yes			
Dial 5	Dial 6	Dial 7	Dial 8	Dial 9

Dial Pad keys

Default

5. Press the TRF key to write the data and advance to the second Doorphone option.
6. After entering the desired data, press the TRF key to write that data and advance to Memory Block 1-34 (SLT Hookflash Signal Selection).
7. Press the SPKR key to go back on-line.

■ Additional Programming

Mode	Data No.	System Data	
		Required	May Be Required
Telephone (LK 4)	17		✓
Telephone (LK 4)	18		✓

NOTES:

1. Two Doorphones can be connected to the system.

GENERAL INFORMATION - DOORPHONE CONNECTION SELECTION

This Memory Block specifies whether or not Doorphones are connected to the system.

SLT HOOKFLASH SIGNAL SELECTION

System	Data No.
1	34

OPERATION:

1. Go off-line.

2. Enter: Mode System LK 1



3. Enter: Data No. 3 | 4
(Dial Pad)

NOTES:

1. If Hold is specified, the CO/PBX line is put on Exclusive Hold.
2. If FLASH is specified, a timed hookflash signal is sent to the outside line.

Data No.	Title	Setting Data
3 4 :	SIGNAL	HOLD

TIME	DISPLAY	

4. Press the corresponding Dial Pad key to change the Setting Data option.

- To change Hold to Flash, press Dial Pad key 1.

Dial 0	Dial 1	Dial 2	Dial 3	Dial 4
Hold	Flash			
Dial 5	Dial 6	Dial 7	Dial 8	Dial 9

Dial Pad keys



Default

5. Press the TRF key to write the selected data and advance to Memory Block 1-35 (Station Master Hunt Number Selection).

6. Press the SPKR key to go back on-line.

■ Additional Programming

Mode	Data No.	System Data	
		Required	May Be Required
Telephone (LK 4)	01		√

GENERAL INFORMATION - SLT HOOKFLASH SIGNAL SELECTION

This Memory Block specifies whether a line is held, or if behind a PBX, a hookflash signal is sent to the CO/PBX when a Single Line Telephone user performs a hookflash.

STATION MASTER HUNT NUMBER SELECTION

System	Data No.
1	35

OPERATION:

1. Go off-line.

2. Enter: Mode System LK 1



3. Enter: Data No. 3 | 5
(Dial Pad)

	Pilot No.		
Data No.	Title	10~50	Setting Data
3 5 :	PILOT	10	NO
TIME	DISPLAY		

4. Press the corresponding Dial Pad key to change the Setting Data option.

- To change No to Yes, press Dial Pad key 1.

Dial 0	Dial 1	Dial 2	Dial 3	Dial 4
No	Yes			
Dial 5	Dial 6	Dial 7	Dial 8	Dial 9

Dial Pad keys

Default

NOTES:

1. Each Master Hunt Number Selection only hunts within the specified tens group (example: 10~19 or 20~29)
2. Station numbers assigned in a hunt group always hunt in sequence from the lowest numbered station in the group to the highest.

Pilot No.	Station No.
10	10~19
20	20~29
30	30~39
40	40~49
50	50~59

5. Press the TRF key to write the selected data and advance to the next pilot number or to Memory Block 1-36 (CO/PBX Access/Release Selection), after pilot number 50.

6. Press the SPKR key to go back on-line.

■ **Additional Programming**

None

GENERAL INFORMATION - STATION MASTER HUNT NUMBER SELECTION

This Memory Block assigns a pilot number to a Master Station Hunt Number.

CO/PBX ACCESS/RELEASE SELECTION

System	Data No.
1	36

OPERATION:

1. Go off-line.

2. Enter: Mode System

LK 1



3. Enter: Data No.

3	6
---	---

(Dial Pad)

Data No.	Title	Setting Data
3 6 :	RELEASE	NO

TIME	DISPLAY	

4. Press the corresponding Dial Pad key to change the Setting Data option.

- To change No to Yes, press Dial Pad key 1.

Dial 0	Dial 1	Dial 2	Dial 3	Dial 4
No	Yes			
Dial 5	Dial 6	Dial 7	Dial 8	Dial 9

Dial Pad keys



Default

5. Press the TRF key to write the selected data and advance to Memory Block 1-37 (VRS Message Recording Time Selection).

6. Press the SPKR key to go back on-line.

■ Additional Programming

None

GENERAL INFORMATION - CO/PBX ACCESS/RELEASE SELECTION

This Memory Block determines whether a CO/PBX line disconnects or no response is provided when pressing a CO/PBX line key that is already accessed.

VRS MESSAGE RECORDING TIME SELECTION

System	Data No.
1	37

OPERATION:

1. Go off-line.

2. Enter: Mode System LK 1

3. Enter: Data No. 3 7
(Dial Pad)

Data No.	Title	Setting Data
3 7 :	VRS	15s × 16

TIME		DISPLAY

4. Press the corresponding Dial Pad key to change the Setting Data option.

- To change 16 messages to 8 messages, press Dial Pad key 1.

Dial 0	Dial 1	Dial 2	Dial 3	Dial 4
(15.0 sec.) * 16	(30.0 sec.) * 8	(60.0 sec.) * 4	(120.0 sec.) * 2	
Dial 5	Dial 6	Dial 7	Dial 8	Dial 9

Dial Pad keys



R.T. = Recording Time
* = No. of messages

5. Press the TRF key to write the selected data and advance to Memory Block 1-38 [VRS/VM Automatic Answer/Automated Attendant (Night) Selection].

6. Press the SPKR key to go back on-line.

■ Additional Programming

Mode	Data No.	System Data	
		Required	May Be Required
System (LK1)	38~44		√

NOTES:

- VRS (Voice Recording Services) has a maximum of 240 seconds for message recording.
 - The number of messages that can be used in the VRS depends on the length of the particular messages (240 sec. ÷ Length of messages = number of messages).

Example:

Message length	15 sec.	:	16 messages
"	"	:	30 sec. : 8 messages
"	"	:	60 sec. : 4 messages
"	"	:	120 sec. : 2 messages

GENERAL INFORMATION - VRS MESSAGE RECORDING TIME SELECTION

This Memory Block specifies the length and number of messages. (The number of messages is dependent on the length of the messages).

VRS/VM AUTOMATIC ANSWER/AUTOMATED ATTENDANT (NIGHT) SELECTION

Table with 2 columns: System, Data No. Values: 1, 38

OPERATION:

NOTES:

1. Go off-line.

2. Enter: Mode System LK 1

3. Enter: Data No. 3 8 (Dial Pad)

- 1. System software version 1.5 or higher is required to support the Automated Attendant feature. 2. V4.50 or higher is required for delayed ringing to external voice mail system.

Table showing Data No. (3 8), Title (VRS NT), and Setting Data (NO) with a dashed line and TIME DISPLAY below.

4. Press the corresponding Dial Pad key to change the Setting Data option.

- To change No to Yes, press Dial Pad key 1.

Grid of Dial Pad keys (Dial 1-9) with a shaded 'Default' area for Dial 1.

Dial Pad keys Default

No = No Automatic Answer/Automated Attendant
Yes = Automatic Answer/Automated Attendant

5. Press the TRF key to write the selected data and advance to Memory Block 1-39 [VRS/VM Automatic Answer/Automated Attendant (Day) Selection].

6. Press the SPKR key to go back on-line.

Additional Programming

Refer to Section 6 - Guide to Feature Programming in this chapter.

GENERAL INFORMATION - VRS/VM AUTOMATIC ANSWER/AUTOMATED ATTENDANT (NIGHT) SELECTION

This Memory Block specifies whether VRS/VM Automatic Answer/Automated Attendant (Night) is allowed or denied. This memory block is also used to enable an external Voice Mail Auto Attendant delayed ringing feature.

VRS/VM AUTOMATIC ANSWER/AUTOMATED ATTENDANT (DAY) SELECTION

System	Data No.
1	39

OPERATION:

1. Go off-line.

2. Enter: Mode System LK 1



3. Enter: Data No. 3 | 9

(Dial Pad)

Data No.	Title	Setting Data
3 9 :	VRS DY	NO

TIME	DISPLAY	

NOTES:

1. System software version 1.5 or higher is required to support the Automated Attendant feature.
2. V4.50 or higher is required for delayed ringing to external voice mail system.

4. Press the corresponding Dial Pad key to change the Setting Data option.

- To change No to Yes, press Dial Pad key 1.

Dial 0	Dial 1	Dial 2	Dial 3	Dial 4
No	Yes			
Dial 5	Dial 6	Dial 7	Dial 8	Dial 9

Dial Pad keys



- No = No Automatic Answer/Automated Attendant
- Yes = Automatic Answer/Automated Attendant

5. Press the TRF key to write the selected data and advance to Memory Block 1-40 [VRS/VM Automatic Answer/Automated Attendant (Weekend) Selection].

6. Press the SPKR key to go back on-line.

■ **Additional Programming**

Refer to Section 6 - Guide to Feature Programming in this chapter.

GENERAL INFORMATION - VRS/VM AUTOMATIC ANSWER/AUTOMATED ATTENDANT (DAY) SELECTION

This Memory Block specifies whether VRS/VM Automatic Answer/Automated Attendant (Day) is allowed or denied. This memory block is also used to enable an external Voice Mail Auto Attendant delayed ringing feature.

VRS/VM AUTOMATIC ANSWER/AUTOMATED ATTENDANT (WEEKEND) SELECTION

System	Data No.
1	40

OPERATION:

NOTES:

1. Go off-line.

2. Enter: Mode System LK 1

3. Enter: Data No. 4 | 0
(Dial Pad)

1. System software version 1.5 or higher is required to support the Automated Attendant feature.
2. V4.50 or higher is required for delayed ringing to external voice mail system.

Data No.	Title	Setting Data
4 0 :	VRS WK	NO

TIME	DISPLAY	

4. Press the corresponding Dial Pad key to change the Setting Data option.

- To change No to Yes, press Dial Pad key 1.

Dial 0	Dial 1	Dial 2	Dial 3	Dial 4
No	Yes			
Dial 5	Dial 6	Dial 7	Dial 8	Dial 9

Dial Pad keys Default

No = No Automatic Answer/Automated Attendant
Yes = Automatic Answer/Automated Attendant

5. Press the TRF key to write the selected data and advance to Memory Block 1-41 (VRS Manual Answer Selection).

6. Press the SPKR key to go back on-line.

■ **Additional Programming**

Refer to Section 6 - Guide to Feature Programming in this chapter.

GENERAL INFORMATION - VRS/VM AUTOMATIC ANSWER/AUTOMATED ATTENDANT (WEEKEND) SELECTION

This Memory Block specifies whether VRS/VM Automatic Answer/Automated Attendant (Weekend) is allowed or denied. This memory block is also used to enable an external Voice Mail Auto Attendant delayed ringing feature.

VRS MANUAL ANSWER SELECTION

System	Data No.
1	41

OPERATION:

1. Go off-line.

2. Enter: Mode System LK 1



3. Enter: Data No. 4 1
(Dial Pad)

Data No.	Title	Setting Data
4 1 :	VRS MAN	NO

TIME	DISPLAY	

4. Press the corresponding Dial Pad key to change the Setting Data option.

- To change No to Yes, press Dial Pad key 1.

Erase	Dial 1	Dial 2	Dial 3	Dial 4
No	Yes			
Dial 5	Dial 6	Dial 7	Dial 8	Dial 9

Dial Pad keys



No = No Manual Answer

Yes = Manual Answer

5. Press the TRF key to write the selected data and advance to Memory Block 1-42 [VRS Automatic Answer/Automated Attendant (Night) Time Assignment].

6. Press the SPKR key to go back on-line.

■ Additional Programming

Mode	Data No.	System Data	
		Required	May Be Required
System (LK 1)	37		√

GENERAL INFORMATION - VRS MANUAL ANSWER SELECTION

This Memory Block specifies whether VRS Manual Answer is allowed or denied.

VRS AUTOMATIC ANSWER/AUTOMATED ATTENDANT (NIGHT) TIME ASSIGNMENT

System	Data No.
1	42

OPERATION:

1. Go off-line.

2. Enter: Mode System



3. Enter: Data No.
(Dial Pad)

Data No.	Title	Setting Data
4 2 :	VRS NTTM	:

TIME	DISPLAY	

4. Enter the data by using the Dial Pad.

- Example: To switch time, enter 20:00

← , → : To move cursor.

Dial pad ~ : To enter Setting Data.

key : To clear all data when cursor is at Data No.

Default	<input type="text" value="Not Specified"/>
---------	--

5. Press the TRF key to write the selected data and advance to Memory Block 1-43 [VRS Automatic Answer/Automated Attendant (Day) Time Assignment].

6. Press the SPKR key to go back on-line.

■ Additional Programming

Refer to Section 6 - Guide to Feature Programming in this chapter.

NOTES:

- | |
|--|
| 1. System software version 1.5 or higher is required to support the Automated Attendant feature. |
|--|

GENERAL INFORMATION - VRS AUTOMATIC ANSWER/AUTOMATED ATTENDANT (NIGHT) TIME ASSIGNMENT

This Memory Block allows automatic switching of the Automatic Answer/Automated Attendant feature into VRS Automatic Answer Night Mode.

VRS AUTOMATIC ANSWER/AUTOMATED ATTENDANT (DAY) TIME ASSIGNMENT

System	Data No.
1	43

OPERATION:

1. Go off-line.

2. Enter: Mode System LK 1



3. Enter: Data No. 4 3
(Dial Pad)

Data No.	Title	Setting Data
4 3 :	VRS DYTM	:

TIME	DISPLAY	

4. Enter the data by using the Dial Pad.

- Example: To switch time, enter 05:00

← * , # → : To move cursor.

Dial pad 0 ~ 9 : To enter Setting Data.

HOLD key : To clear all data when cursor is at Data No.

Default	Not Specified
---------	---------------

5. Press the TRF key to write the selected data and advance to Memory Block 1-44 [VRS Automatic Answer/Automated Attendant (Off) Time Assignment].
6. Press the SPKR key to go back on-line.

■ Additional Programming

Refer to Section 6 - Guide to Feature Programming in this chapter.

NOTES:

1. System software version 1.5 or higher is required to support the Automated Attendant feature.

GENERAL INFORMATION - VRS AUTOMATIC ANSWER/AUTOMATED ATTENDANT (DAY) TIME ASSIGNMENT

This Memory Block allows automatic switching of the VRS Automatic Answer/Automated Attendant feature into Day Mode.

VRS AUTOMATIC ANSWER/AUTOMATED ATTENDANT (OFF) TIME ASSIGNMENT

System	Data No.
1	44

OPERATION:

1. Go off-line.

2. Enter: Mode System LK 1



3. Enter: Data No. 4 4
(Dial Pad)

Data No.	Title	Setting Data
4 4 :	VRS OFTM	:

TIME	DISPLAY	

4. Enter the data by using the Dial Pad.

- Example: To switch time, enter 08:00

← * , # → : To move cursor.

Dial pad 0 ~ 9 : To enter Setting Data.

HOLD key : To clear all data when cursor is at Data No.

Default Not Specified

5. Press the TRF key to write the selected data and advance to Memory Block 1-45 (Doorphone Preference Selection).
6. Press the SPKR key to go back on-line.

■ **Additional Programming**

Refer to Section 6 - Guide to Feature Programming in this chapter.

GENERAL INFORMATION - VRS AUTOMATIC ANSWER/AUTOMATED ATTENDANT (OFF) TIME ASSIGNMENT

This Memory Block automatically switches off the Automatic Answer/Automated Attendant feature.

DOORPHONE PREFERENCE SELECTION

System	Data No.
1	45

OPERATION:

1. Go off-line.

2. Enter: Mode System LK 1



3. Enter: Data No. 4 5
(Dial Pad)

Data No.	Title	Setting Data
4 5 :	DPH PRF	YS

TIME	DISPLAY	

4. Press the corresponding Dial Pad key to change the Setting Data option.

- To change Yes to No, press Dial Pad key 0.

Dial 0	Dial 1	Dial 2	Dial 3	Dial 4
No	Yes			
Dial 5	Dial 6	Dial 7	Dial 8	Dial 9

Dial Pad keys

Default

5. Press the TRF key to write the selected data and advance to Memory Block 1-46 (Manual Line Seizure Selection).

6. Press the SPKR key to go back on-line.

■ Additional Programming

Mode	Data No.	System Data	
		Required	May Be Required
System (LK 1)	33	✓	
Telephone (LK 4)	17		✓
Telephone (LK 4)	18		✓

GENERAL INFORMATION - DOORPHONE PREFERENCE SELECTION

This Memory Block specifies whether or not each station user is allowed to answer Doorphone calls by lifting the handset.

MANUAL LINE SEIZURE SELECTION

System	Data No.
1	46

OPERATION:

1. Go off-line.

2. Enter: Mode System LK 1



3. Enter: Data No. 4 | 6
(Dial Pad)

Data No.	Title	Setting Data
4 6 :	MANUAL	YS

TIME	DISPLAY	

4. Press the corresponding Dial Pad key to change the Setting Data option.

- To change Yes (Manual Line Seizure) to No (No Manual Line Seizure), press Dial Pad key 0.

Dial 0	Dial 1	Dial 2	Dial 3	Dial 4
No	Yes			
Dial 5	Dial 6	Dial 7	Dial 8	Dial 9

Dial Pad keys



Default

- No = No manual line seizure
- Yes = Manual line seizure

- Press the TRF key to write the selected data and advance to Memory Block 1-47 (Hold Free Transfer Selection).
- Press the SPKR key to go back on-line.

- Additional Programming
None

GENERAL INFORMATION - MANUAL LINE SEIZURE SELECTION

This Memory Block specifies whether or not an outgoing CO/PBX line can be seized by pressing the line key in an on-hook condition.

HOLD FREE TRANSFER SELECTION

System	Data No.
1	47

OPERATION:

1. Go off-line.

2. Enter: Mode System LK 1



3. Enter: Data No. 4 7
(Dial Pad)

Data No.	Title	Setting Data
4 7 :	HDFREE TRF	NO

TIME DISPLAY		

4. Press the corresponding Dial Pad key to change the Setting Data option.

- To change No to Yes, press Dial Pad key 1.

Dial 0	Dial 1	Dial 2	Dial 3	Dial 4
No	Yes			
Dial 5	Dial 6	Dial 7	Dial 8	Dial 9

Dial Pad keys

Default

No = Hold Free Transfer Deny
Yes = Hold Free Transfer Allow

5. Press the TRF key to write the selected data and advance to Memory Block 1-48 (General Purpose Relay Assignment).

6. Press the SPKR key to go back on-line.

■ Additional Programming

None

NOTES:

1. When Hold Free Transfer is assigned, trunk queuing cannot be accessed by pressing a specific CO/PBX line.

GENERAL INFORMATION - HOLD FREE TRANSFER SELECTION

This Memory Block specifies whether Hold Free Transfer is allowed or denied.

GENERAL PURPOSE RELAY ASSIGNMENT

System	Data No.
1	48

OPERATION:

1. Go off-line.

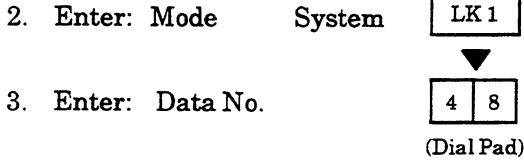

Data No.	Title	Relay No. 1~4	Setting Data
4 8 :	RLY 1		NON

	TIME	DISPLAY	

4. Press the corresponding Dial Pad key to change the Setting Data option.

- To change Non to Doorphone 1, press Dial Pad key 1.

Dial 0	Dial 1	Dial 2	Dial 3	Dial 4
Non	Door Lock Release 1	Door Lock Release 2	External Speaker	MOH/BGM
Dial 5	Dial 6	Dial 7	Dial 8	Dial 9
External Tone Ringer	FAX (V.20 or higher)			

Dial Pad keys Default

← * , # → : To move cursor.

Dial pad 0 ~ 1 : To change the Setting Data

5. Press the TRF key to write the selected data and advance to the next relay or to Memory Block 1-49 (Synchronous Ringing Selection).

6. Press the SPKR key to go back on-line.

NOTES:

- The General Purpose Relays are assigned as follows:
 - Door Lock Release (1 and/or 2)
 - External Amplifier Control (for External Paging)
 - External Music On Hold (MOH)/Background Music (BGM) Control
 - External Tone Ring/Night Chime Control
 - Facsimile (Relay 3 or 4 is recommended)
- The General Purpose Relays cannot be assigned to more than one function at the same time.
- System software version 2.0 or higher is required for fax connection.

- Additional Programming
- None

GENERAL INFORMATION - GENERAL PURPOSE RELAY ASSIGNMENT

This Memory Block assigns a function to each of the General Purpose Relays.

SYNCHRONOUS RINGING SELECTION

System	Data No.
1	49

OPERATION:

1. Go off-line.

2. Enter: Mode System LK 1



3. Enter: Data No. 4 9
(Dial Pad)

Data No.	Title	Setting Data
4 9 :	SYNCHRONUS	YS

TIME	DISPLAY	

4. Press the corresponding Dial Pad key to change the Setting Data option.

- To change Yes to No, press Dial Pad key 0.

Dial 0	Dial 1	Dial 2	Dial 3	Dial 4
No	Yes			
Dial 5	Dial 6	Dial 7	Dial 8	Dial 9

Dial Pad keys

Default

5. Press the TRF key to write the selected data and advance to Memory Block 1-50 (Elapsed Call Time Display Selection).

6. Press the SPKR key to go back on-line.

■ Additional Programming

None

NOTES:

1. Synchronous Ringing does not apply to Off-Hook Ringing calls.
2. When Synchronous Ringing is off, a 2-second on, 4-second off ring pattern is provided by the system.

GENERAL INFORMATION - SYNCHRONOUS RINGING SELECTION

This Memory Block specifies whether or not incoming CO/PBX calls can be programmed for Synchronous Ringing.

ELAPSED CALL TIME DISPLAY SELECTION

System	Data No.
1	50

OPERATION:

1. Go off-line.

2. Enter: Mode System LK 1
- ▼
3. Enter: Data No. 5 | 0
- (Dial Pad)

Data No.	Title	Setting Data
5 0 :	DSP TM	YS

TIME	DISP L A Y	

4. Press the corresponding Dial Pad key to change the Setting Data option.
- To change Yes to No, press Dial Pad key 0.

Dial 0	Dial 1	Dial 2	Dial 3	Dial 4
No	Yes			
Dial 5	Dial 6	Dial 7	Dial 8	Dial 9

Dial Pad keys Default

5. Press the TRF key to write the selected data and advance to Memory Block 1-51 (Music On Hold Selection).
6. Press the SPKR key to go back on-line.

- Additional Programming
- None

GENERAL INFORMATION - ELAPSED CALL TIME DISPLAY SELECTION

This Memory Block specifies whether elapsed call time display is allowed or denied on a system-wide basis.

MUSIC ON HOLD SELECTION

System	Data No.
1	51

OPERATION:

1. Go off-line.

2. Enter: Mode System LK 1

3. Enter: Data No. 5 1
(Dial Pad)

Data No.	Title	Setting Data
5 1 :	MOH	LETITBE

TIME	DISPLAY	

4. Press the corresponding Dial Pad key to change the Setting Data option.

- To change Let It Be to Melody Fair, press Dial Pad key 1.

Dial 0	Dial 1	Dial 2	Dial 3	Dial 4
Let It Be	Melody			
Dial 5	Dial 6	Dial 7	Dial 8	Dial 9

Dial Pad keys

Default

5. Press the TRF key to write the selected data and advance to Memory Block 1-52 (External MOH Selection).

6. Press the SPKR key to go back on-line.

■ Additional Programming

Mode	Data No.	System Data	
		Required	May Be Required
System (LK1)	52		✓

NOTES:

1. Music On Hold can be provided to CO/PBX and internal calls that are put on hold.
2. One of two melodies for Music On Hold can be selected in this Memory Block.

Let It Be = Let It Be

Melody = Melody Fair

GENERAL INFORMATION - MUSIC ON HOLD SELECTION

This Memory Block specifies the Music On Hold pattern for all CO/PBX lines and internally held calls when External Music On Hold is not selected in Memory Block 1-52 (External MOH Selection).

EXTERNAL MOH SELECTION

System	Data No.
1	52

OPERATION:

1. Go off-line.

2. Enter: Mode System LK 1



3. Enter: Data No. 5 2
(Dial Pad)

Data No.	Title	Setting Data
5 2 :	EXT MOH	NO

TIME	DISPLAY	

4. Press the corresponding Dial Pad key to change the Setting Data option.

- To change No to Yes, press Dial Pad key 1.

Dial 0	Dial 1	Dial 2	Dial 3	Dial 4
No	Yes			
Dial 5	Dial 6	Dial 7	Dial 8	Dial 9

Dial Pad keys



Default

5. Press the TRF key to write the selected data and advance to Memory Block 1-53 (External Ring Selection).

6. Press the SPKR key to go back on-line.

■ Additional Programming

None

NOTES:

1. When external MOH is set to Yes, the internal music source is turned off.

GENERAL INFORMATION - EXTERNAL MOH SELECTION

This Memory Block specifies whether External MOH is connected (Yes or No).

EXTERNAL RING SELECTION

System	Data No.
1	53

OPERATION:

1. Go off-line.

2. Enter: Mode System LK 1



3. Enter: Data No. 5 | 3
(Dial Pad)

Data No.	Title	Setting Data
5 3 :	EXT RG	NON

TIME	DISP LAY	

4. Press the corresponding Dial Pad key to change the Setting Data option.

- To change Non to Speaker, press Dial Pad key 2.

Dial 0	Dial 1	Dial 2	Dial 3	Dial 4
Non	Rly	Sp	Rly & Sp	
Dial 5	Dial 6	Dial 7	Dial 8	Dial 9

Dial Pad keys



Default

- NON = No Assignment
- RLY = External Ring Control
- SP = External Tone Ringer with External Speaker (Day Mode)

5. Press the TRF key to write the selected data and advance to Memory Block 1-54 (Night Chime Selection).

6. Press the SPKR key to go back on-line.

■ Additional Programming

Mode	Data No.	System Data	
		Required	May Be Required
System (LK1)	48	✓	

GENERAL INFORMATION - EXTERNAL RING SELECTION

This Memory Block specifies whether external ringing activates a General Purpose Relay, an external speaker, both relays and speaker, or no external ringing.

NIGHT CHIME SELECTION

System	Data No.
1	54

OPERATION:

1. Go off-line.

2. Enter: Mode System LK 1



3. Enter: Data No. 5 | 4
 (Dial Pad)

Data No.	Title	Setting Data
5 4 :	NT CHM	NON
TIME DISPLAY		

4. Press the corresponding Dial Pad key to change the Setting Data option.

- To change Non to Speaker, press Dial Pad key 2.

Dial 0	Dial 1	Dial 2	Dial 3	Dial 4
Non	Rly	Sp	Rly & Sp	
Dial 5	Dial 6	Dial 7	Dial 8	Dial 9

Dial Pad keys



Default

NON = No Assignment

RLY = Night Chime Control

SP = Night Chime with External Speaker (Night Mode)

5. Press the TRF key to write the selected data and advance to Memory Block 1-55 (Class of Service Feature Selection).

6. Press the SPKR key to go back on-line.

■ **Additional Programming**

Mode	Data No.	System Data	
		Required	May Be Required
System (LK1)	48	√	

GENERAL INFORMATION - NIGHT CHIME SELECTION

This Memory Block specifies whether external ringing activates a General Purpose Relay, an external speaker, both relays and speaker, or no external ringing.

CLASS OF SERVICE FEATURE SELECTION

System	Data No.
1	55

OPERATION:

1. Go off-line.

2. Enter: Mode System LK 1

3. Enter: Data No. 5 5

(Dial Pad)

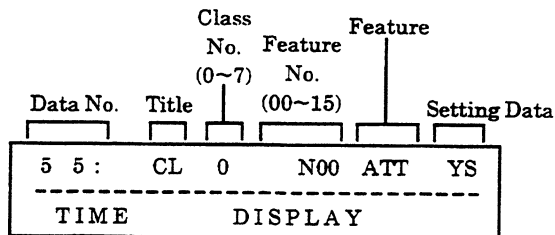

4. Press the corresponding Dial Pad key to change the Setting Data option.

• To change Yes to No, press Dial Pad key 0.

Dial 0	Dial 1	Dial 2	Dial 3	Dial 4
No (Deny)	Yes (Allow)			
Dial 5	Dial 6	Dial 7	Dial 8	Dial 9

Dial Pad keys

Default

Default	Class 0	: No 00, 03~15 (Yes) No 01 and 02 (No)
	Class 1	: No 00~02 (No) No 03~15 (Yes)
	Class 2~7	: All (No)

5. Press the TRF key; the entered data is written and the data for the next Feature No./Class No. is displayed.

6. After entering the desired data for all the last Feature Nos. and Class Nos., press the TRF key to write the data and advance to Memory Block 1-56 (8-Digit Matching Table Assignment).

7. Press the SPKR key to go back on-line.

NOTES:

1. Eight classes (0~7) of feature restriction patterns allow a station user to activate particular features while restricting the user from other features.

Classes 1~7 programmed in this Memory Block are programmed as feature restriction classes. In Telephone Mode, Memory Blocks 4-19 and 4-20, specify any of the classes for each telephone to specify the features that the user can or cannot activate.

Class		Feature No.	Feature
00	01		
Y	N	00	Attendant Type Features
N	N	01	Barge-In Originate
N	N	02	Barge-In Receive
Y	Y	03	Paging Access
Y	Y	04	Off-Hook Ringing
Y	Y	05	Do Not Disturb
Y	Y	06	Call Forward - All Calls
Y	Y	07	Call Forward Busy/No Answer Set
Y	Y	08	Trunk Queuing
Y	Y	09	Automatic Callback
Y	Y	10	Callback Request
Y	Y	11	VRS Voice Message Set/Record/Verify/Cancel
Y	Y	12	Tone Override/Voice Over Busy/Camp-On Originate
Y	Y	13	Tone Override/Camp-On Receiving/Voice Over Busy Receive
Y	Y	14	Room Monitor Originate
Y	Y	15	Room Monitor Receive

Additional Programming

Mode	Data No.	System Data	
		Required	May Be Required
Telephone (LK4)	19		✓
Telephone (LK4)	20		✓

GENERAL INFORMATION - CLASS OF SERVICE FEATURE SELECTION

This Memory Block allows or denies a particular Class of Service.

8-DIGIT MATCHING TABLE ASSIGNMENT

System	Data No.
1	56

OPERATION:

1. Go off-line.

2. Enter: Mode System **LK 1**

3. Enter: Data No. **5 6**
(Dial Pad)

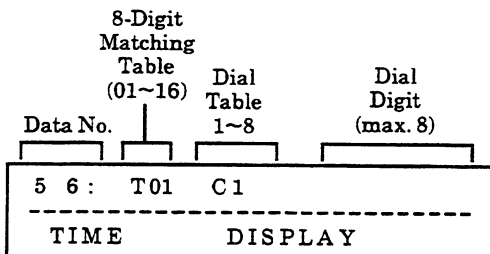

4. Enter the data by using the Dial Pad.

Data: Matching Table: 01~16 (8-digit)
 Dial Table: 1~8
 Dial Digit: 0~9, *, #,
 NANP = X, P, N
 (Max. eight digits)

← ***** , **#** → : To move cursor.

Dial pad **0** ~ **9** : To enter Setting Data.

HOLD key : Set Data Clear

Operation Data	Dial Number	Operation
X	0~9, *, #	LNR/SPD key + 7
P	0~1	LNR/SPD key + 8
N	2~9	LNR/SPD key + 9
*	*	LNR/SPD key + *
#	#	LNR/SPD key + #

NOTES:

1. There are 16, 8-Digit Matching Tables. Each 8-Digit Matching Table contains eight Dial Tables. Each Dial Table can be assigned a maximum of eight digits, including *, #, X, P, and N.

- Press the TRF key; the entered data is written and the data for the next Dial Table/8-Digit Matching Table is displayed.
- After entering the desired data for the last Dial Tables and 8-Digit Matching Tables, press the TRF key to write the data and advance to Memory Block 1-57 (Class Allow/Deny Assignment).
- Press the SPKR key to go back on-line.

■ Additional Programming

Mode	Data No.	System Data	
		Required	May Be Required
System (LK 1)	58		✓
Telephone (LK 4)	22		✓

GENERAL INFORMATION - 8-DIGIT MATCHING TABLE ASSIGNMENT

This Memory Block assigns the outgoing dial digits for Code Restriction (except OCC Dial Digits). There are two ways to program this assignment: a) If the user dials a digit(s) and there is a match, the system can allow free dialing or deny dialing by disconnecting. This is programmed in Memory Block 1-58 (8-Digit Matching Table to Class Assignment). b) If the user dials a digit(s) and there is not a match, the system can allow free dialing or deny dialing by disconnecting. This is programmed in Memory Block 1-57 (Class Allow/Deny Assignment).

CLASS ALLOW/DENY ASSIGNMENT

System	Data No.
1	57

OPERATION:

1. Go off-line.

2. Enter: Mode System LK1



3. Enter: Data No. 5 7
(Dial Pad)

Data No.	Title	Class (1~6)	Function
5 7 :	CLASS	1 =	NO

TIME		DISPLAY	

4. Press the corresponding Dial Pad key to change the Setting Data option.

- To change Yes to No, press Dial Pad key 0.

Dial 0	Dial 1	Dial 2	Dial 3	Dial 4
No	Yes			
Dial 5	Dial 6	Dial 7	Dial 8	Dial 9

Dial Pad keys

No = Deny
Yes = Allow

Default	Class 0	Yes (allow) [fixed]
	Class 1~4	Yes (allow)
	Class 5~6	No (deny)
	Class 7	No (deny) [fixed]

5. Press the TRF key; the entered data is written and the data for the next Class No. is displayed.

6. After entering the desired data for the last Class No., press the TRF key to write the data and advance to Memory Block 1-58 (8-Digit Matching Table to Class Assignment).

7. Press the SPKR key to go back on-line.

NOTES:

1. Class 0 is fixed as Yes (allow).
2. Class 7 is fixed as No (deny).
3. Only Classes 1~6 are programmable and can be accessed from this Memory Block.

■ Additional Programming

Mode	Data No.	System Data	
		Required	May Be Required
System (LK1)	56		√
System (LK1)	58		√

GENERAL INFORMATION - CLASS ALLOW/DENY ASSIGNMENT

This Memory Block allows the assignment of allow or deny for the Class Assignment tables. This assignment is used when there is no match in the 8-Digit Matching Table or if numbers overlap (duplicate numbers with different Allow/Deny designations within the same Class of Service table) in the 8-Digit Matching Tables.

8-DIGIT MATCHING TABLE TO CLASS ASSIGNMENT

System	Data No.
1	58

OPERATION:

1. Go off-line.

2. Enter: Mode System LK 1

3. Enter: Data No. 5 | 8
(Dial Pad)

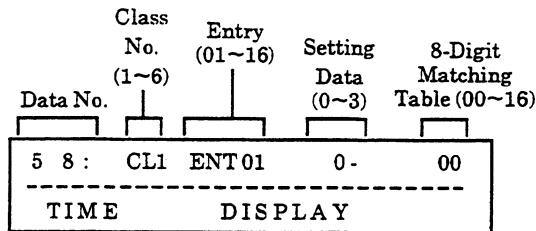

4. Press the corresponding Dial Pad key to change the Setting Data option.

Class: 1~6 8-Digit Matching Table 01~16 and 00 = Not Assigned

Entry: 01~16

Setting Data:

- 0 = Deny
- 1 = Allow
- 2 = Deny (OCC Calls Only)
- 3 = Allow (OCC Calls Only)

NOTES:

1. Class 0 is fixed as Allow.
2. Class 7 is fixed as Deny.
3. Only Classes 1~6 can be accessed from this Memory Block.
4. A maximum of six, 8-digit matching tables can be assigned to each Class (version 2.0 or lower).
5. Version 2.72 and higher software expands the table entries from six tables maximum to 16 tables maximum per station class.

5. Press the TRF key; the entered data is written and the data for the next Class Assignment Table/Class No. is displayed.
6. After entering the desired data for the last Class Assignment Tables and Classes, press the TRF key to write the data and advance to Memory Block 1-59 (8-Digit Matching Table to Trunk Group Assignment).
7. Press the SPKR key to go back on-line.

Dial 0	Dial 1	Dial 2	Dial 3	Dial 4
(0) Deny	(1) Allow			
Dial 5	Dial 6	Dial 7	Dial 8	Dial 9

Dial Pad keys

Default

■ Additional Programming

Mode	Data No.	System Data	
		Required	May Be Required
System (LK1)	56		✓
System (LK1)	57		✓
System (LK1)	59		✓

GENERAL INFORMATION - 8-DIGIT MATCHING TABLE TO CLASS ASSIGNMENT

Each 8-Digit Matching Table can be programmed as Allow or Deny on a per-class basis. Classes 0 and 7 are fixed (cannot be programmed). Classes 1~6 are programmable.

8-DIGIT MATCHING TABLE TO TRUNK GROUP ASSIGNMENT

System	Data No.
1	59

OPERATION:

1. Go off-line.

2. Enter: Mode System LK 1



3. Enter: Data No. 5 9
(Dial Pad)

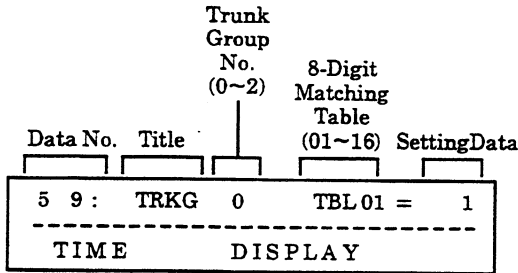

4. Press the corresponding Dial Pad key to change the Setting Data option.

- Trunk Group No. : 0~2
 8-Digit Matching Table No. : 01~16
 Setting Data : 0 = Disable
 1 = Enable

Dial 0	Dial 1	Dial 2	Dial 3	Dial 4
Disable	Enable			
Dial 5	Dial 6	Dial 7	Dial 8	Dial 9

Dial Pad keys Default

5. Press the TRF key; the entered data is written and the data for the next 8-Digit Matching Table/Trunk Group No. is displayed.

6. After entering the desired data for the last 8-Digit Matching Tables and Trunk Groups, press the TRF key to write the data and advance to Memory Block 1-60 (OCC Table Assignment).

7. Press the SPKR key to go back on-line.

■ Additional Programming

Mode	Data No.	System Data	
		Required	May Be Required
System (LK1)	56		✓
System (LK1)	57		✓
System (LK1)	58		✓
CO/PBX (LK3)	11		✓

GENERAL INFORMATION - 8-DIGIT MATCHING TABLE TO TRUNK GROUP ASSIGNMENT

This Memory Block assigns each Trunk Group to the 8-Digit Matching Tables.

OCC TABLE ASSIGNMENT

System	Data No.
1	60

OPERATION:

1. Go off-line.

2. Enter: Mode System LK1

3. Enter: Data No. 6 0
(Dial Pad)

Data No.	OCC Table (01~16)	Setting Data
6 0 :	CD 01	

TIME	DISPLAY	

4. Use the Dial Pad keys to change the Setting Data option.

Data: OCC Table : 01~16 (8-digit)
Dial Digit : 0~9, *, #, NANP= X, P, N (Max. eight digits)

← * , # → : To move cursor.

Dial pad 0 ~ 9 : To enter Setting Data.

HOLD key : Set Data Clear

Operation Data	Dial Number	Operation
X	0~9, *, #	LNR/SPD key + 7
P	0*1	LNR/SPD key + 8
N	2~9	LNR/SPD key + 9
*	*	LNR/SPD key + *
#	#	LNR/SPD key + #

5. Press the TRF key; the entered data is written and the data for the next OCC Table is displayed.

6. After entering the desired data for the last OCC Tables, press the TRF key to write the data and advance to Memory Block 1-61 (OCC Table To Trunk Group Assignment).

7. Press the SPKR key to go back on-line.

Default	OCC Table 01~ 15	Vacant
	OCC Table 16	10KXX

■ Additional Programming

Mode	Data No.	System Data	
		Required	May Be Required
System (LK1)	61		✓
System (LK1)	62		✓

GENERAL INFORMATION - OCC TABLE ASSIGNMENT

This Memory Block allows an OCC Code (maximum of eight digits) to be assigned in this table. Up to 16 numbers can be assigned in this table.

OCC TABLE TO TRUNK GROUP ASSIGNMENT

System	Data No.
1	61

OPERATION:

1. Go off-line.

2. Enter: Mode System LK 1



3. Enter: Data No. 6 1
(Dial Pad)

Data No.	Trunk Group No. (0~2)	OCC Table (01~16)	Setting Data
6 1	: TRKG 0	CD 01 =	YS
TIME		DISPLAY	

4. Press the corresponding Dial Pad key to change the Setting Data option.

- To change Yes to No, press Dial Pad key 0.

Dial 0	Dial 1	Dial 2	Dial 3	Dial 4
No	Yes			
Dial 5	Dial 6	Dial 7	Dial 8	Dial 9

Dial Pad keys

Default

Trunk Group No. : 0~2

OCC

Table No. : 01~16

Setting Data : Yes = Enable
 No = Disable

5. Press the TRF key; the entered data is written and the data for the next OCC Table/Trunk Group is displayed.

6. After entering the desired data for the last OCC Table and Trunk Group, press the TRF key to write the data and advance to Memory Block 1-62 (8-Digit Matching Table to OCC Table Assignment).

7. Press the SPKR key to go back on-line.

■ Additional Programming

Mode	Data No.	System Data	
		Required	May Be Required
System (LK1)	60		✓
System (LK1)	62		✓

GENERAL INFORMATION - OCC TABLE TO TRUNK GROUP ASSIGNMENT

This Memory Block assigns each of the 16 OCC Tables to each Trunk Group.

8-DIGIT MATCHING TABLE TO OCC TABLE ASSIGNMENT

System	Data No.
1	62

OPERATION:

1. Go off-line.

2. Enter: Mode System LK 1

3. Enter: Data No. 6 2
(Dial Pad)

Data No.	OCC Table (01~16)	8-Digit Matching Table (01~16)	Setting Data
6 2	CD 01	TBL 01	= NO

TIME		DISPLAY	

4. Use the Dial Pad keys to change the Setting Data option.

- To change Yes to No, press Dial Pad key 0.

Dial 0	Dial 1	Dial 2	Dial 3	Dial 4
No	Yes			
Dial 5	Dial 6	Dial 7	Dial 8	Dial 9

Dial Pad keys

- 8-Digit Matching : 01~16
- OCC Table No. : 01~16
- Setting Data : Yes = All OCC Numbers Assigned
No = Not Assigned

Default	No (Not Assigned)
---------	-------------------

- Press the TRF key; the entered data is written and the data for the next 8-Digit Matching Table/OCC Table is displayed.
- After entering the desired data for all the last 8-Digit Matching Table and OCC Table, press the TRF key to write the data and to advance to Memory Block 1-63 (Internal/External Paging Alert Tone Selection).
- Press the SPKR key to go back on-line.

■ Additional Programming

Mode	Data No.	System Data	
		Required	May Be Required
System (LK1)	56		✓
System (LK1)	60		✓
System (LK1)	61		✓

GENERAL INFORMATION - 8-DIGIT MATCHING TABLE TO OCC TABLE ASSIGNMENT

This Memory Block assigns each of the 8-Digit Matching Tables to each of the OCC Tables.

INTERNAL/EXTERNAL PAGING ALERT TONE SELECTION

System	Data No.
1	63

OPERATION:

1. Go off-line.

2. Enter: Mode System LK 1



3. Enter: Data No. 6 | 3
(Dial Pad)

Data No.	Title	Setting Data
6 3 :	PAG ALERT	YS

TIME	DISPLAY	

4. Press the corresponding Dial Pad key to change the Setting Data option.

- To change Yes to No, press Dial Pad key 0.

Dial 0	Dial 1	Dial 2	Dial 3	Dial 4
No	Yes			
Dial 5	Dial 6	Dial 7	Dial 8	Dial 9

Dial Pad keys

Default

5. Press the TRF key to write the selected data and advance to Memory Block 1-64 (SLT Transfer Selection).

6. Press the SPKR key to go back on-line.

■ **Additional Programming**

None

GENERAL INFORMATION - INTERNAL/EXTERNAL PAGING ALERT TONE SELECTION

This Memory Block determines whether or not a Call Alert Tone is provided when Internal/External Paging is used.

SLT TRANSFER SELECTION

System	Data No.
1	64

OPERATION:

1. Go off-line.

2. Enter: Mode System LK 1



3. Enter: Data No. 6 4
(Dial Pad)

Data No.	Title	Setting Data
6 4 :	SLT TRF	HOOK

TIME	DISPLAY	

4. Press the corresponding Dial Pad key to change the Setting Data option.

- To change Hook to Hang Up, press Dial Pad key 1.

Dial 0	Dial 1	Dial 2	Dial 3	Dial 4
Hook	Hang Up			
Dial 5	Dial 6	Dial 7	Dial 8	Dial 9

Dial Pad keys



Default

Hook = Hooking (Hookflash → Station Number → Hookflash → Hang up)
[SLT]
Hang Up = On-Hook (Hookflash → Station Number → Hang up)
[Voice Mail]

5. Press the TRF key to write the selected data and advance to Memory Block 1-65 [Printer Connected (Alarm) Selection].

6. Press the SPKR key to go back on-line.

■ Additional Programming

None

NOTES:

1. This Memory Block affects Single Line Telephone/Voice Mail Ports.

GENERAL INFORMATION - SLT TRANSFER SELECTION

This Memory Block selects the transfer function of a Single Line Telephone Voice Mail Port.

PRINTER CONNECTED (ALARM) SELECTION

System	Data No.
1	65

OPERATION:

1. Go off-line.

2. Enter: Mode System LK 1



3. Enter: Data No. 6 | 5
(Dial Pad)

Data No.	Title	Setting Data
6 5 :	PRINTER	YS

TIME	DISPLAY	

4. Press the corresponding Dial Pad key to change the Setting Data option.

- To change Yes to No, press Dial Pad key 0.

Dial 0	Dial 1	Dial 2	Dial 3	Dial 4
No	Yes			
Dial 5	Dial 6	Dial 7	Dial 8	Dial 9

Dial Pad keys



5. Press the TRF key to write the selected data and advance to Memory Block 1-66 (SMDR Print Format).

6. Press the SPKR key to go back on-line.

■ **Additional Programming**

None

NOTES:

1. Program for Yes when a printer is connected.
2. SMDR cannot be used if this Memory Block is programmed for No.
3. Programming this Memory Block is required only when the SMDR-C-10 KTU unit is installed.

GENERAL INFORMATION - PRINTER CONNECTED (ALARM) SELECTION

This Memory Block must be programmed for Yes when a printer is connected. If the printer is disconnected from the system, an alarm sounds at stations connected to Ports 01 and 02.

SMDR PRINT FORMAT

System	Data No.
1	66

OPERATION:

1. Go off-line.

2. Enter: Mode System LK 1



3. Enter: Data No. 6 6
(Dial Pad)

Data No.	Title	Setting Data
6 6 :	FORMAT	ALL

TIME	DISPLAY	

4. Press the corresponding Dial Pad key to change the Setting Data option.

- To change All to Mask, press Dial Pad key 1.

Dial 0	Dial 1	Dial 2	Dial 3	Dial 4
All	Mask			
Dial 5	Dial 6	Dial 7	Dial 8	Dial 9

Dial Pad keys



Default

- Press the TRF key to write the selected data and advance to Memory Block 1-67 (Voice Mail Access Code Assignment).
- Press the SPKR key to go back on-line.

■ Additional Programming

Mode	Data No.	System Data	
		Required	May Be Required
System (LK1)	65		✓

GENERAL INFORMATION - SMDR PRINT FORMAT

This Memory Block specifies if All digits are to be printed. If Mask is specified, the last four digits are masked and XXXX is printed.

VOICE MAIL ACCESS CODE ASSIGNMENT

System	Data No.
1	67

OPERATION:

1. Go off-line.

2. Enter: Mode System LK 1

3. Enter: Data No. 6 7
(Dial Pad)

Data No.	Access Code No. (1~11)	Title	Setting Data (max. 4 digits)
6 7 :	VM01	RLI	

TIME		DISPLAY	

4. Enter the data by using the Dial Pad.

← * , # → : To move cursor.

Dial pad 0 ~ 9 : To enter Setting Data.

LNR/SPD + * = *

LNR/SPD + # = #

HOLD key : To clear Set Data

Default	Access Code 01 ~ 09:	All Blank
	Access Code 10:	641
	Access Code 11:	64*

5. Press the TRF key; the entered data is written and the data for the next Voice Mail Access Code is displayed.

6. After entering the desired data for the last Voice Mail Access Code, press the TRF key to write the data and advance to Memory Block 1-68 (Voice Mail DTMF Delay Timer Selection).

7. Press the SPKR key to go back on-line.

NOTES:

1. A maximum number of four digits can be used as Access Codes.
2. A loop open disconnect signal is sent when Access Code No. 09 is blank (version 2.72 software or higher and an SLT-F(1G)-20 ADP is required).

Access Code No.	Access Feature
01	Remote Logon (Internal)
02	Direct Logon
03	Transfer Message
04	Record Message
05	Forward All Calls
06	Forward Busy
07	Forward No Answer
08	Remote Logon (Trunk)
09	DTMF Disconnect Signal
10	Message Wait Indication (set)
11	Message Wait Indication (cancel)

Additional Programming

Mode	Data No.	System Data	
		Required	May Be Required
System (LK1)	68		✓
System (LK1)	69		✓

GENERAL INFORMATION - VOICE MAIL ACCESS CODE ASSIGNMENT

This Memory Block specifies the Access Codes required for integrating to Voice Mail.

VOICE MAIL DTMF DELAY TIMER SELECTION

System	Data No.
1	68

OPERATION:

1. Go off-line.

2. Enter: Mode System LK 1



3. Enter: Data No. 6 8
(Dial Pad)

Data No.	Title	Setting Data
6 8 :	VM DLY	1.0s

TIME DISPLAY		

4. Press the corresponding Dial Pad key to enter the Setting Data option.

- To change 1.0 sec. to 2.0 sec., press Dial Pad key 4.

Dial 0	Dial 1	Dial 2	Dial 3	Dial 4
0 sec.	0.1 sec.	0.5 sec.	1.0 sec.	2.0 sec.
Dial 5	Dial 6	Dial 7	Dial 8	Dial 9
4.0 sec.	6.0 sec.	8.0 sec.	10.0 sec.	14.0 sec.

Dial Pad keys



Default

5. Press the TRF key to write the selected data and advance to Memory Block 1-69 (Voice Mail DTMF Duration/Interdigit Time Selection).
6. Press the SPKR key to go back on-line.

■ Additional Programming

Mode	Data No.	System Data	
		Required	May Be Required
System (LK1)	67	✓	
System (LK1)	69		✓

GENERAL INFORMATION - VOICE MAIL DTMF DELAY TIMER SELECTION

This Memory Block specifies the delay time before DTMF tones are sent to the Voice Mail ports.

VOICE MAIL DTMF DURATION/INTERDIGIT TIME SELECTION

System	Data No.
1	69

OPERATION:

1. Go off-line.

2. Enter: Mode System LK 1

3. Enter: Data No. 6 9
(Dial Pad)

Data No.	Title	Setting Data
6 9 :	VM DUR	100/70

TIME		DISPLAY

4. Press the corresponding Dial Pad key to enter the Setting Data option.

- To change 100/70 ms. to 600/100 ms., press Dial Pad key 4.

Dial 0	Dial 1	Dial 2	Dial 3	Dial 4
70/60 ms.	100/50 ms.	100/70 ms.	400/100 ms.	600/100 ms.
Dial 5	Dial 6	Dial 7	Dial 8	Dial 9
900/200 ms.				

Dial Pad keys Default

Default	Duration Time: 100 ms.
	Interdigit Time: 70 ms.

5. Press the TRF key to write the selected data and advance to Memory Block 1-70 (System Refresh Timer Selection).

6. Press the SPKR key to go back on-line.

■ Additional Programming

None

GENERAL INFORMATION - VOICE MAIL DTMF DURATION/INTERDIGIT TIME SELECTION

This Memory Block specifies the DTMF duration and Interdigit time for Voice Mail.

SYSTEM REFRESH TIMER SELECTION

System	Data No.
1	70

OPERATION:

1. Go off-line.

2. Enter: Mode System LK 1

3. Enter: Data No. 7 | 0
(Dial Pad)

Data No.	Title	Setting Data
7 0 :	REFRESH	4H

TIME	DISPLAY	

4. Press the corresponding Dial Pad key to enter the Setting Data option.

- To change 4 hr. to 8 hr., press Dial Pad key 2.

Dial 0	Dial 1	Dial 2	Dial 3	Dial 4
No Refresh	4 hr.	8 hr.	12 hr.	24 hr.
Dial 5	Dial 6	Dial 7	Dial 8	Dial 9

Dial Pad keys Default

- Press the TRF key to write the selected data and advance to Memory Block 1-71 (VRS Answer Mode Selection).
- Press the SPKR key to go back on-line.

- Additional Programming
None

GENERAL INFORMATION - SYSTEM REFRESH TIMER SELECTION

This Memory Block assigns the System Refresh Time. The system refreshes itself during idle periods.

AUTOMATED ATTENDANT PBR RELEASE TIMER SELECTION

System	Data No.
1	73

OPERATION:

1. Go off-line.

2. Enter: Mode System

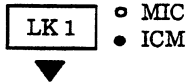

3. Enter: Data No.

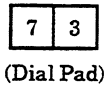

NOTES:

1. System software version 1.5 or higher is required to support the Automated Attendant.

Data No.	Title	Setting Data
7 3 :	AA PBR TIME	20 s

TIME		DISPLAY

4. Press the corresponding Dial Pad key to change setting data option.

- To change 20 sec. to 30 sec., press Dial Pad key 3.

Dial 0	Dial 1	Dial 2	Dial 3	Dial 4
0 sec.	10 sec.	20 sec.	30 sec.	40 sec.
Dial 5	Dial 6	Dial 7	Dial 8	Dial 9
50 sec.	60 sec.			

Dial Pad keys

Default

5. Press the TRF key to write the selected data and advance to Memory Block 1-74 (Automated Attendant Delay Ringing Time Selection).

6. Press the SPKR key to go back on-line.

■ **Additional Programming**

Refer to Section 6 - Guide to Feature Programming in this chapter.

GENERAL INFORMATION - AUTOMATED ATTENDANT PBR RELEASE TIMER SELECTION

This Memory Block specifies the time during which a receiver is connected when a calling party is dialing through an Automated Attendant trunk.

AUTOMATED ATTENDANT DELAY RINGING TIME SELECTION

System	Data No.
1	74

OPERATION:

1. Go off-line.

2. Enter: Mode System

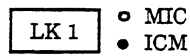

3. Enter: Data No.

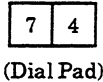

Data No.	Title	Setting Data
7 4 :	AADLYRNG	∞

TIME		DISPLAY

4. Press the corresponding Dial Pad key to change setting data option.

- To change ∞ to 10 sec., press Dial Pad key 1.

Dial 0	Dial 1	Dial 2	Dial 3	Dial 4
*	10 sec.	20 sec.	30 sec.	
Dial 5	Dial 6	Dial 7	Dial 8	Dial 9

Dial Pad keys



Default

5. Press the TRF key to write the selected data and advance to Memory Block 1-75 (Automated Attendant No Answer Disconnect Time Selection).

6. Press the SPKR key to go back on-line.

■ **Additional Programming**

Refer to Section 6 - Guide to Feature Programming in this chapter.

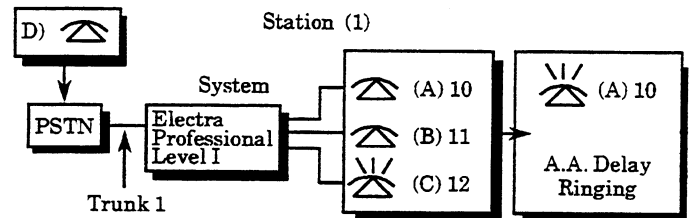

10~12 = Station Number

PSTN = Public Switching Telephone Network

- Trunk 1 is assigned to Automated Attendant Trunk.
- Automated Attendant transfers to station 12.
- Unanswered transfer delay rings to station 10.

NOTES:

1. When outside party D wishes to speak to station user A:
 - a. Dial the telephone number corresponding to Trunk 1.
 - b. Confirm Automated Attendant message.
 - c. Dial 1-digit extension.
2. At station A:
 - a. The ICM LED blinks and a ring tone different from the normal ringing tone is heard.
 - b. The call can be answered by lifting the handset.
3. If station user A does not answer within the specified time:
 - a. The ringing cycle changes to the normal cycle and CO line 1 starts ringing at stations assigned for Automated Attendant Delay Ring [Memory Block 4-24 (Automated Attendant Delay Ring Assignment)].
 - b. Any station user (A, B, or C) can answer the call.
4. System software version 1.5 or higher is required to support the Automated Attendant.

GENERAL INFORMATION - AUTOMATED ATTENDANT DELAY RINGING TIME SELECTION

This Memory Block specifies the time for a No Answer at the transferred station before the Automated Attendant changes to ordinary CO/PBX ringing.

AUTOMATED ATTENDANT NO ANSWER DISCONNECT TIME SELECTION

System	Data No.
1	75

OPERATION:

1. Go off-line.

2. Enter: Mode System

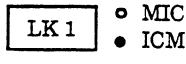

3. Enter: Data No.

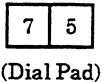

Data No.	Title	Setting Data
7 5 :	AA DIS	1m

TIME	DISPLAY	

4. Press the corresponding Dial Pad key to change setting data option.

- To change 2 min. to 3 min., press Dial Pad key 2.

Dial 0	Dial 1	Dial 2	Dial 3	Dial 4
1 min.	2 min.	3 min.	4 min.	∞
Dial 5	Dial 6	Dial 7	Dial 8	Dial 9

Dial Pad keys

Default

5. Press the TRF key to write the selected data and advance to Memory Block 1-76 (Automated Attendant No DTMF Detect Selection).

6. Press the SPKR key to go back on-line.

■ Additional Programming

Refer to Section 6 - Guide to Feature Programming in this chapter.

NOTES:

1. If the called party does not answer within the predetermined time, the call is disconnected.
2. System software version 1.5 or higher is required to support the Automated Attendant.
3. System software version 2.72 or higher is required to support the ∞ timer.

GENERAL INFORMATION - AUTOMATED ATTENDANT NO ANSWER DISCONNECT TIME SELECTION

This Memory Block determines how long the Automated Attendant rings a station before disconnecting the caller.

AUTOMATED ATTENDANT ACCESS CODE ASSIGNMENT

System	Data No.
1	77

OPERATION:

1. Go off-line.

2. Enter: Mode System

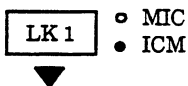

3. Enter: Data No.

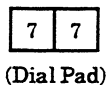

NOTES:

System software version 1.5 or higher is required to support the Automated Attendant.

Data No.	Title	Code No.	Setting Data
77	AAAC	- 0	=

TIME		DISPLAY	

4. Enter code number using the Dial Pad.

Dial pad 0 ~ 9 : To enter data.

Setting Data: Station Number (10 ~ 59)
 Delayed Ringing Position (00)

Default	Not specified
---------	---------------

5. Press the TRF key to write the selected data and advance to the next Code No.

6. After all data is entered, press the TRF key to write the selected data and advance to Memory Block 1-78 (Fax Line Reservation Time Selection).

7. Press the SPKR key to go back on-line.

■ **Additional Programming**

Refer to Section 6 - Guide to Feature Programming in this chapter.

GENERAL INFORMATION - AUTOMATED ATTENDANT ACCESS CODE ASSIGNMENT

This Memory Block routes a call that has come in to the Automated Attendant by entering a 1-digit code.

FAX LINE RESERVATION TIMER SELECTION

System	Data No.
1	78

OPERATION:

1. Go off-line.

2. Enter: Mode System LK 1



3. Enter: Data No. 7 8

(Dial Pad)

Data No.	Title	Setting Data
7 8 :	FAXRSV	= 30

TIME	DISP L A Y	

4. Press the corresponding Dial Pad key to enter the Setting Data option.

- To change 30 sec. to 60 sec., press Dial Pad key 1.

Dial 0	Dial 1	Dial 2	Dial 3	Dial 4
30 sec.	60 sec.	120 sec.	240 sec.	
Dial 5	Dial 6	Dial 7	Dial 8	Dial 9

Dial Pad keys



Default

5. Press the TRF key to write the selected data and advance to Memory Block 1-01 [Hookflash Time Selection (Multiline Terminal)].
6. Press the SPKR key to go back on-line.

NOTES:

System software version 2.0 or higher is required.

GENERAL INFORMATION - FAX LINE RESERVATION TIMER SELECTION

This Memory Block specifies the time the CO/PBX line is reserved for exclusive use by a facsimile machine.

THIS PAGE INTENTIONALLY LEFT BLANK

TRUNK TO TENANT ASSIGNMENT

Tenant	Data No.
2	01

OPERATION:

1. Go off-line.

2. Enter: Mode Tenant LK 2



3. Enter: Data No. 0 1
(Dial Pad)

Tenant No. (00~03)	Data No.	Title	Trunk No. (1~8)	Setting 0 or 1
01 /	01 :	TNT-TRK	1	YS

TIME		DISPLAY		

4. Press the corresponding Dial Pad to change the Setting Data option.

← * , # → : To move cursor.

Dial pad 0 ~ 9 : To enter data.

Dial 0	Dial 1	Dial 2	Dial 3	Dial 4
No	Yes			
Dial 5	Dial 6	Dial 7	Dial 8	Dial 9

5. Press the TRF key to write the selected data; data for the next Trunk No. and Tenant No. are displayed.

6. After entering the desired data for the last Trunk No. and Tenant No., press the TRF key to write the data (no advance).

7. Press the SPKR key to go back on-line.

Default	Tenant 00:	CO/PBX lines 01~08 Assigned (Yes)
	Tenant 01~03:	CO/PBX lines 01~08 Assigned (No)

■ Additional Programming

Mode	Data No.	System Data	
		Required	May Be Required
Telephone (LK 4)	09		✓

GENERAL INFORMATION - TRUNK TO TENANT ASSIGNMENT

This Memory Block specifies assignment of CO/PBX lines to each tenant group.

THIS PAGE INTENTIONALLY LEFT BLANK

CO/PBX DTMF DURATION/INTERDIGIT ASSIGNMENT

CO/PBX	Data No.
3	07

OPERATION:

1. Go off-line.

2. Enter: Mode CO/PBX LK 3



3. Enter: Data No. 0 7
(Dial Pad)

CO/PBX No. (01~08)	Data No.	Title	Setting Data
0 1 /	07	MF	70/60

TIME		DISPLAY	

NOTES:

1. When DTMF is selected using Memory Block 3-10 [CO Line Section (Installed, DP, DTMF)], specify the time duration and the interdigit interval between digits sent.
2. Dial Pad key 5 is used for Special Test Mode (internal use only).

4. Move the cursor to the data position, and press the corresponding Dial Pad key to change Setting Data option.

- To change DTMF Duration 70 ms. and Interdigit Time 60 ms. to DTMF Duration 100 ms. and Interdigit Time 70 ms., press Dial Pad key 1.

Dial 0	Dial 1	Dial 2	Dial 3	Dial 4
D.T. 70 ms. I.T. 60 ms.	D.T. 100 ms. I.T. 70 ms.	D.T. 400 ms. I.T. 100 ms.	D.T. 600 ms. I.T. 100 ms.	D.T. 900 ms. I.T. 200 ms.
Dial 5	Dial 6	Dial 7	Dial 8	Dial 9
00/0				

Dial Pad keys Default
 D.T. = DTMF Digit Duration
 I.T. = Interdigit Time

5. Press the TRF key to write the selected data; data for the next CO/PBX No. is displayed.

6. After entering data for the last CO/PBX No., press the TRF key to write the data and advance to Memory Block 3-08 (Trunk Status Selection).

7. Press the SPKR key to go back on-line.

■ Additional Programming

Mode	Data No.	System Data	
		Required	May Be Required
CO/PBX (LK 3)	10		✓

GENERAL INFORMATION - CO/PBX DTMF DURATION/INTERDIGIT ASSIGNMENT

This Memory Block specifies the tone duration and interdigit time of DTMF signals.

TRUNK STATUS SELECTION

CO/PBX	Data No.
3	08

OPERATION:

1. Go off-line.

2. Enter: Mode CO/PBX LK 3



3. Enter: Data No. 0 8
(Dial Pad)

CO/PBX No. (01~08)	Data No.	Setting Data
0 1 /	0 8	OUT & IN

TIME		DISPLAY

4. Move the cursor to the data position, and press the corresponding Dial Pad to change the Setting Data option.

- To change Out & In to In, press Dial Pad key 1.

Dial 0	Dial 1	Dial 2	Dial 3	Dial 4
Out & In	In			
Dial 5	Dial 6	Dial 7	Dial 8	Dial 9

Dial Pad keys



Default

5. Press the TRF key to write the selected data; data for the next CO/PBX No. is displayed.

6. After entering data for the last CO/PBX No., press the TRF key to write the data and advance to Memory Block 3-09 (Trunk Type Selection).

7. Press the SPKR key to go back on-line.

■ **Additional Programming**

None

GENERAL INFORMATION - TRUNK STATUS SELECTION

This Memory Block specifies whether a CO/PBX line is used for call origination and termination or termination only.

TRUNK TYPE SELECTION

CO/PBX	Data No.
3	09

OPERATION:

1. Go off-line.

2. Enter: Mode CO/PBX LK 3



3. Enter: Data No. 0 9
(Dial Pad)

CO/PBX No. (01~08)	Data No.	Title	SettingData
0 1 /	09 :	TRTY	CO
-----		TIME DISPLAY	

4. Move the cursor to the data position, and press the corresponding Dial Pad key to change the Setting Data option.

- To change CO to PBX line, press Dial Pad key 1.

Dial 0	Dial 1	Dial 2	Dial 3	Dial 4
CO	PBX			
Dial 5	Dial 6	Dial 7	Dial 8	Dial 9

Dial Pad keys



Default

5. Press the TRF key to write the selected data; data for the next CO/PBX No. is displayed.

6. After entering data for the last CO/PBX No., press the TRF key to write the data and advance to Memory Block 3-10 [CO Line Selection (Installed, DP, DTMF)].

7. Press the SPKR key to go back on-line.

■ Additional Programming

None

GENERAL INFORMATION - TRUNK TYPE SELECTION

This Memory Block specifies each external line as CO Line or PBX line.

CO LINE SELECTION (INSTALLED, DP, DTMF)

CO/PBX	Data No.
3	10

OPERATION:

1. Go off-line.

2. Enter: Mode CO/PBX LK 3



3. Enter: Data No. 1 0
(Dial Pad)

CO/PBX No. (01~08)	Data No.	Title	Setting Data
0 1 /	10 :	TYPE	MF
-----		TIME	DISPLAY

4. Move the cursor to the data position, and press the corresponding Dial Pad key to change the Setting Data option.

- To change MF to DP 10 pps, press Dial Pad key 1.

Dial 0	Dial 1	Dial 2	Dial 3	Dial 4
NIL	DP 10 pps	DP 20 pps	MF	
Dial 5	Dial 6	Dial 7	Dial 8	Dial 9

Dial Pad keys



Default

5. Press the TRF key to write the selected data; data for the next CO/PBX No. is displayed.

6. After entering data for the last CO/PBX No., press the TRF key to write the data and advance to Memory Block 3-11 (Trunk-to-Trunk Group Assignment).

7. Press the SPKR key to go back on-line.

■ Additional Programming

Mode	Data No.	System Data	
		Required	May Be Required
System (LK 1)	07		✓

GENERAL INFORMATION - CO LINE SELECTION (INSTALLED, DP, DTMF)

This Memory Block specifies each external line as DP (10 pps or 20 pps), DTMF, or not connected (NIL).

TRUNK-TO-TRUNK GROUP ASSIGNMENT

CO/PBX	Data No.
3	11

OPERATION:

1. Go off-line.

2. Enter: Mode CO/PBX LK 3



3. Enter: Data No. 1 1
(Dial Pad)

CO/PBX No. (01~08)	Data No.	Title	Trunk Group No. (0~2)
0 1 /	11	TRK GP	= 0

TIME		DISPLAY	

NOTES:

1. Three Trunk Groups are available in the system.
2. Assign a Trunk Group Number to each CO/PBX Line (1~8).
3. When an Access Code corresponding to a Trunk Group is dialed, an idle CO/PBX line is automatically selected and seized either from the same Trunk Group (CO/PBX line of the same tenant) or from another tenant.

4. Move the cursor to the data position, and press the corresponding Dial Pad key to change the Setting Data option.

Example: Enter TRK GP 1 using the Dial Pad key.

- ← * , # → : To move cursor.
- Dial pad 0 ~ 9 : To enter data.
- Data { 0~2 : Trunk Group 0~2

Default All CO/PBX lines Group 0

5. Press the TRF key to write the selected data; data for the next CO/PBX No. is displayed.
6. After entering data for the last CO/PBX No., press the TRF key to write the data and advance to Memory Block 3-12 (CO/PBX Line Code Restriction Override Selection).
7. Press the SPKR key to go back on-line.

■ Additional Programming
None

GENERAL INFORMATION - TRUNK-TO-TRUNK GROUP ASSIGNMENT

This Memory Block assigns trunks to each Trunk Group.

CO/PBX LINE CODE RESTRICTION OVERRIDE SELECTION

CO/PBX	Data No.
3	12

OPERATION:

1. Go off-line.

2. Enter: Mode CO/PBX LK 3



3. Enter: Data No. 1 2
(Dial Pad)

CO/PBX No. (01~08)	Data No.	Title	SettingData
0 1 /	12	NONREST	NO
TIME		DISPLAY	

4. Move the cursor to the data position, and press the corresponding Dial Pad key to change the Setting Data option.

- To change No to Yes, press Dial Pad key 1.

Dial 0	Dial 1	Dial 2	Dial 3	Dial 4
No	Yes			
Dial 5	Dial 6	Dial 7	Dial 8	Dial 9

Dial Pad keys

Default

Yes = Not Restricted

No = Restricted (Code Table check)

5. Press the TRF key to write the selected data; data for the next CO/PBX No. is displayed.

6. After entering data for the last CO/PBX No., press the TRF key to write the data and advance to Memory Block 3-14 (Trunk-to-Trunk Transfer Yes/No Selection).

7. Press the SPKR key to go back on-line.

■ Additional Programming

None

GENERAL INFORMATION - CO/PBX LINE CODE RESTRICTION OVERRIDE SELECTION

This Memory Block specifies CO/PBX lines to override the code restriction process on a per-line basis.

TRUNK-TO-TRUNK TRANSFER YES/NO SELECTION

CO/PBX	Data No.
3	14

OPERATION:

1. Go off-line.

2. Enter: Mode CO/PBX LK 3

▼

3. Enter: Data No. 1 4

(Dial Pad)

CO/PBX No. (01~08)	Data No.	Title	Setting Data
0 1 /	14	TRK -TRK	NO
TIME		DISPLAY	

← * , # → : To move cursor.

Dial pad 0 ~ 9 : To enter data.

4. Move the cursor to the data position, and press the corresponding Dial Pad key to change the Setting Data option.

- To change No to Yes, press Dial Pad key 1.

Dial 0	Dial 1	Dial 2	Dial 3	Dial 4
No	Yes			
Dial 5	Dial 6	Dial 7	Dial 8	Dial 9

Dial Pad keys Default

5. Press the TRF key to write the selected data; data for the next CO/PBX No. is displayed.

6. After entering data for the last CO/PBX No., press the TRF key to write the data and advance to Memory Block 3-15 (VRS Automatic Answer Yes/No Selection).

7. Press the SPKR key to go back on-line.

■ Additional Programming

None

GENERAL INFORMATION - TRUNK-TO-TRUNK TRANSFER YES/NO SELECTION

This Memory Block specifies whether to allow or deny Trunk-To-Trunk Transfer.

VRS/VM AUTOMATIC ANSWER YES/NO SELECTION

CO/PBX	Data No.
3	15

OPERATION:

1. Go off-line.

2. Enter: Mode CO/PBX LK 3



3. Enter: Data No. 1 5
(Dial Pad)

CO/PBX No. (01~08)	Data No.	Title	Setting Data
0 1 /	15	AASEL	NO

TIME		DISPLAY	

4. Move the cursor to the data position, and press the corresponding Dial Pad key to change the Setting Data option.

- To change No to Yes, press Dial Pad key 1.

Dial 0	Dial 1	Dial 2	Dial 3	Dial 4
No	VRS	VM		
Dial 5	Dial 6	Dial 7	Dial 8	Dial 9

Dial Pad keys Default

- No = Deny
- VRS = Allow
- VM = Allow

5. Press the TRF key to write the selected data; data for the next CO/PBX No. is displayed.

6. After entering data for the last CO/PBX No., press the TRF key to write the data and advance to Memory Block 3-16 (PBX Night Transfer Selection).

7. Press the SPKR key to go back on-line.

■ Additional Programming

Refer to Section 6 - Guide to Feature Programming in this chapter.

NOTES:

1. The VRS Automatic Answer/Automated Attendant feature answers calls in the Day, Night and Weekend Modes when assigned.
2. System software version 1.5 or higher is required to support the Automated Attendant feature.
3. System software version 4.50 will provide delayed ringing to external voice mail machines when dial 2 (VM) is selected in this memory block.

GENERAL INFORMATION - VRS/VM AUTOMATIC ANSWER YES/NO SELECTION

This Memory Block specifies whether the Automatic Answer/Automated Attendant feature is allowed or denied.

PBX NIGHT TRANSFER SELECTION

CO/PBX	Data No.
3	16

OPERATION:

1. Go off-line.

2. Enter: Mode CO/PBX LK 3



3. Enter: Data No. 1 6
(Dial Pad)

CO Port No. (01~08)	Data No.	Title	Setting Data
0 1 /	16	PBXNT	NO

TIME		DISPLAY	

4. Move the cursor to the data position, and press the corresponding Dial Pad key to change the Setting Data option.

- To change No to Yes, press Dial Pad key 1.

Dial 0	Dial 1	Dial 2	Dial 3	Dial 4
No	Yes			
Dial 5	Dial 6	Dial 7	Dial 8	Dial 9

Dial Pad keys

Default

Yes = PBX (PBX code is deleted during Night Mode.)
 No = PBX (PBX code is not deleted during Night Mode.)

5. Press the TRF key to write the selected data; data for the next CO/PBX No. is displayed.

6. After entering data for the last CO/PBX No., press the TRF key to write the data and advance to Memory Block 3-17 (DP Dial Make Ratio Selection).

7. Press the SPKR key to go back on-line.

■ Additional Programming

None

GENERAL INFORMATION - PBX NIGHT TRANSFER SELECTION

This Memory Block automatically deletes the PBX Access Code when the system is switched into Night Mode for each CO/PBX line.

DP DIAL MAKE RATIO SELECTION

CO/PBX	Data No.
3	17

OPERATION:

1. Go off-line.

2. Enter: Mode CO/PBX LK 3



3. Enter: Data No. 1 7
(Dial Pad)

CO/PBX No. (01~08)	Data No.	Title	Setting Data
0 1 /	17	INIT	39%

TIME		DISPLAY	

4. Press the corresponding Dial Pad key to change the Setting Data option.

- To change 39% to 33%, press Dial Pad key 0.

Dial 0	Dial 1	Dial 2	Dial 3	Dial 4
33%	39%			
Dial 5	Dial 6	Dial 7	Dial 8	Dial 9

Dial Pad keys



Default

5. Press the TRF key to write the selected data; data for the next CO/PBX No. is displayed.

6. After entering data for the last CO/PBX No., press the TRF key to write the data and advance to Memory Block 3-18 (VRS Hold Message Assignment).

7. Press the SPKR key to go back on-line.

■ Additional Programming

None

GENERAL INFORMATION - DP DIAL MAKE RATIO SELECTION

This Memory Block selects the make ratio for Dial Pulse lines.

VRS HOLD MESSAGE ASSIGNMENT

CO/PBX	Data No.
3	18

OPERATION:

1. Go off-line.

2. Enter: Mode CO/PBX LK 3



3. Enter: Data No. 1 8
(Dial Pad)

CO Port No. (01~08)	Data No.	Title	Setting Data
0 1 /	18 :	HDMSG =	NO

TIME		DISPLAY	

4. Move the cursor to the data position, and press the corresponding Dial Pad key to change the Setting Data option.

- To change No to Yes, press Dial Pad key 1.

Dial 0	Dial 1	Dial 2	Dial 3	Dial 4
No	Yes			
Dial 5	Dial 6	Dial 7	Dial 8	Dial 9

Dial Pad keys

Default

Yes = Allow

No = Deny

5. Press the TRF key to write the selected data; data for the next CO/PBX No. is displayed.

6. After entering data for the last CO/PBX No., press the TRF key to write the data and advance to Memory Block 3-19 [Telephone Number to Trunk Assignment (CO7)].

7. Press the SPKR key to go back on-line.

■ Additional Programming

None

GENERAL INFORMATION - VRS HOLD MESSAGE ASSIGNMENT

This Memory Block specifies whether or not to send a Voice Message to the outside party when a call is placed on hold.

TELEPHONE NUMBER TO TRUNK ASSIGNMENT (CO 7)

CO/PBX	Data No.
3	19

OPERATION:

1. Go off-line.

2. Enter: Mode CO/PBX LK 3



3. Enter: Data No. 1 9
(Dial Pad)

Data No.	Setting Data (13 digits max.)
19/ _	-----
TIME	DISPLAY

NOTES:

1. System software version 3.0 or higher is required.
2. CO/PBX lines 1~6 are assigned in Memory Blocks 3-01~06.

4. Enter data using the Dial Pad.

- To program 214-753-4000, enter 214-753-4000 using the Dial Pad.

← * , # → : To move cursor

Dial pad 0 ~ 9 : To enter data (13 digits max.)

LNR/SPD key : "--" (Hyphen)

key : " " (Space)

HOLD key : To clear data

Default Not Specified

5. After entering data for the Memory Block, press the TRF key to write the data and advance to Memory Block 3-20 [Telephone Number to Trunk Assignment (CO8)].

6. Press the SPKR key to go back on-line.

■ Additional Programming

Mode	Data No.	System Data	
		Required	May Be Required
CO/PBX (LK 3)	01~06		√

GENERAL INFORMATION - TELEPHONE NUMBER TO TRUNK ASSIGNMENT (CO 7)

This Memory Block associates the telephone number with CO/PBX line 07. The telephone number associated with the CO/PBX line is displayed on the Multiline Terminal when originating or answering a CO/PBX call. (The telephone number is entered in the Setting Data option and is a maximum of 13 digits.)

TELEPHONE NUMBER TO TRUNK ASSIGNMENT (CO 8)

CO/PBX	Data No.
3	20

OPERATION:

1. Go off-line.

2. Enter: Mode CO/PBX LK 3



3. Enter: Data No. 2 0
(Dial Pad)

NOTES:

1. System software version 3.0 or higher is required.
2. CO/PBX lines 1-6 are assigned in Memory Blocks 3-01-06.

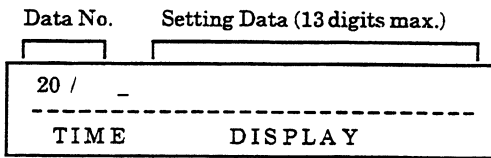

4. Enter data using the Dial Pad.

- To program 214-753-4000, enter 214-753-4000 using the Dial Pad.

← * , # → : To move cursor

Dial pad 0 ~ 9 : To enter data (13 digits max.)

LNR/SPD key : "--" (Hyphen)

key : " " (Space)

HOLD key : To clear data

Default Not Specified

5. After entering data for the Memory Block, press the TRF key to write the data and advance to Memory Block 3-01 [Telephone Number to Trunk Assignment (CO1)].

6. Press the SPKR key to go back on-line.

- Additional Programming
None

GENERAL INFORMATION - TELEPHONE NUMBER TO TRUNK ASSIGNMENT (CO 8)

This Memory Block associates the telephone number with CO/PBX line 08. The telephone number associated with the CO/PBX line is displayed on the Multiline Terminal when originating or answering a CO/PBX call. (The telephone number is entered in the Setting Data option and is a maximum of 13 digits.)

SLT CONNECTED YES/NO SELECTION

Telephone	Data No.
4	01

OPERATION:

1. Go off-line.

2. Enter: Mode Telephone LK 4



3. Enter: Data No. 0 1
(Dial Pad)

Tel Port No. (01~16)	Data No.	Title	Setting Data
0 1 /	01	: SLT	NO
-----		-----	
TIME		DISPLAY	

4. Press the corresponding Dial Pad key to change the Setting Data option.

- To change No to Yes, press Dial Pad key 1.

Dial 0	Dial 1	Dial 2	Dial 3	Dial 4
No	Yes			
Dial 5	Dial 6	Dial 7	Dial 8	Dial 9

Dial Pad keys



Default

5. Press the TRF key; the entered data is written and the data for the next Tel Port No. is displayed.
6. After entering the desired data for the last Tel Port No., press the TRF key to write the data and advance to Memory Block 4-02 (Telephone to Tenant Assignment).
7. Press the SPKR key to go back on-line.

- Additional Programming
None

NOTES:

1. Specify Yes if the port number displayed is a Single Line Telephone.
2. Specify No if the port number in the display is a Multiline Terminal.
3. Do not specify Yes for telephones in Ports 01 and 02.
4. This assignment is automatically made when an SLT-F(1G)-10 ADP or SLT-T(1G)-20 ADP is installed on an ESI Port.

GENERAL INFORMATION - SLT CONNECTED YES/NO SELECTION

This Memory Block specifies whether or not a Single Line Telephone is connected to a Multiline Terminal port.

TELEPHONE TO TENANT ASSIGNMENT

Telephone	Data No.
4	02

OPERATION:

1. Go off-line.

2. Enter: Mode Telephone LK 4



3. Enter: Data No. 0 2
(Dial Pad)

Tel Port No. (01~16)	Data No.	Title	Setting Data
0 1 /	0 2 :	TENANT	= 0

TIME	DISPLAY		

4. Enter data using the Dial Pad.

Example: To enter TENANT 1 for TEL 01, enter 1 using the Dial Pad.

← * , # → : To move cursor.

Dial pad 0 ~ 9 : To enter Setting Data.

Default	All Telephones Tenant 0
---------	-------------------------

5. Press the TRF key; the entered data is written and the data for the next Tel Port No. is displayed.
6. After entering the desired data for the last Tel Port No., press the TRF key to write the data and advance to Memory Block 4-03 (Internal Zone Paging Selection).
7. Press the SPKR key to go back on-line.

■ Additional Programming

Mode	Data No.	System Data	
		Required	May Be Required
Tenant (LK2)	1		✓

GENERAL INFORMATION - TELEPHONE TO TENANT ASSIGNMENT

This Memory Block specifies tenant assignment on a per-station basis.

INTERNAL ZONE PAGING SELECTION

Telephone	Data No.
4	03

OPERATION:

1. Go off-line.

2. Enter: Mode Telephone LK 4



3. Enter: Data No. 0 3
(Dial Pad)

Tel Port No. (01~16)	Data No.	Title	Setting Data
0 1 /	03	: PAGE	GPA

TIME		DISPLAY	

4. Press the corresponding Dial Pad key to change the Setting Data option.

- To change Group A to No, press Dial Pad key 0.

Dial 0	Dial 1	Dial 2	Dial 3	Dial 4
No	Group A	Group B	Group C	
Dial 5	Dial 6	Dial 7	Dial 8	Dial 9

Dial Pad keys



Default

5. Press the TRF key; the entered data is written and the data for the next Tel Port No. is displayed.
6. After entering the desired data for the last Tel Port No., press the TRF key to write the data and advance to Memory Block 4-04 (Ringing Line Preference Selection).
7. Press the SPKR key to go back on-line.

■ Additional Programming

None

NOTES:

1. Any of the following three zones can be specified.
Zone A: Paged by Dialing 71.
Zone B: Paged by Dialing 72.
Zone C: Paged by Dialing 73.
2. Telephones can be assigned to No Zone.
3. Single Line Telephones cannot receive an internal page.

GENERAL INFORMATION - INTERNAL ZONE PAGING SELECTION

This Memory Block places stations into internal page zones.

RINGING LINE PREFERENCE SELECTION

Telephone	Data No.
4	04

OPERATION:

1. Go off-line.

2. Enter: Mode Telephone LK 4



3. Enter: Data No. 0 4
(Dial Pad)

Tel Port No. (01~16)	Data No.	Title	Setting Data
0 1 /	0 4	RING PRF	NO
-----		TIME	DISPLAY

4. Press the corresponding Dial Pad key to change the setting the data option.

- To change No to Yes, press Dial Pad key 1.

Dial 0	Dial 1	Dial 2	Dial 3	Dial 4
No	Yes			
Dial 5	Dial 6	Dial 7	Dial 8	Dial 9

Dial Pad keys

Default

5. Press the TRF key; the entered data is written and the data for the next Tel Port No. is displayed.
6. After entering the desired data for the last Tel Port No., press the TRF key to write the data and advance to Memory Block 4-05 (DTMF/DP SLT Type Selection).
7. Press the SPKR key to go back on-line.

■ Additional Programming

Mode	Data No.	System Data	
		Required	May Be Required
Telephone (LK 4)	15		✓
Telephone (LK 4)	16		✓

GENERAL INFORMATION - RINGING LINE PREFERENCE SELECTION

This Memory Block specifies whether or not each station user can answer incoming CO/PBX calls automatically on Ring Assigned CO/PBX Lines by lifting the handset.

DTMF/DP SLT TYPE SELECTION

Telephone	Data No.
4	05

OPERATION:

1. Go off-line.

2. Enter: Mode Telephone LK 4



3. Enter: Data No. 0 5
(Dial Pad)

Tel Port No. (01~16)	Data No.	Title	Setting Data
0 1 /	05	SLT TYP	MF
TIME		DISPLAY	

4. Press the corresponding Dial Pad key to change the Setting Data option.

- To change Tel Port No. 01 from MF to DP, press Dial Pad key 0.

Dial 0	Dial 1	Dial 2	Dial 3	Dial 4
DP	MF			
Dial 5	Dial 6	Dial 7	Dial 8	Dial 9

Dial Pad keys



Default

5. Press the TRF key; the entered data is written and the data for the next Tel Port No. is displayed.
6. After entering the desired data for the last Tel Port No., press the TRF key to write the data and advance to Memory Block 4-06 (Station Number Assignment).
7. Press the SPKR key to go back on-line.

■ Additional Programming

Mode	Data No.	System Data	
		Required	May Be Required
Telephone (LK4)	01		✓

GENERAL INFORMATION - DTMF/DP SLT TYPE SELECTION

This Memory Block specifies the type of Single Line Telephone that is connected to the system (DP or DTMF) on a per-port basis.

STATION NUMBER ASSIGNMENT

Telephone	Data No.
4	06

OPERATION:

1. Go off-line.

2. Enter: Mode Telephone LK 4



3. Enter: Data No. 0 6

(Dial Pad)

Tel Port No. (01~16)	Data No.	Title	Setting Data (2-digit: 10~59)
0 1 /	06 :	EXT	= 10

TIME		DISPLAY	

4. Press the corresponding Dial Pad key to change the Setting Data option.

- To change Tel Port No. 01 to Station No. 11, enter 11 using the Dial Pad.

← * , # → : To move cursor.

Dial pad 0 ~ 9 : To enter Setting Data.

Default	
Tel Port No.	Sta. No. 2-digit
01	10
02	11
03	12
04	13
05	14
06	15
f	f
16	25

- Press the TRF key; the entered data is written and the data for the next Tel Port No. is displayed.
- After entering the desired data for the last Tel Port No., press the TRF key to write the data and advance to Memory Block 4-07 (Voice Mail/SLT Selection).
- Press the SPKR key to go back on-line.

- Additional Programming
None

NOTES:

- Station Number Assignment is on a per-station basis. (A telephone cannot have two station numbers, and a station number cannot be assigned to more than one telephone.)

[Example]

Tel Port	Station Number	
	Default	→ Change
01	10	11
02	11	10
03	12	46
04	13	59
05	14	Not changed (14)
06	15	Not changed (15)
f	f	f
16	25	Not changed (25)

- Station numbers can range from 10~59.

GENERAL INFORMATION - STATION NUMBER ASSIGNMENT

This Memory Block assigns a station number to each telephone.

VOICE MAIL/SLT SELECTION

Telephone	Data No.
4	07

OPERATION:

1. Go off-line.

2. Enter: Mode Telephone LK 4



3. Enter: Data No. 0 7
(Dial Pad)

Tel Port No. (01~16)	Data No.	Title	Setting Data
0 1 /	0 7 :	VMAIL	NO

TIME		DISPLAY	

4. Press the corresponding Dial Pad key to change the Setting Data option.

- To change No to Yes, press Dial Pad key 1.

Dial 0	Dial 1	Dial 2	Dial 3	Dial 4
No	Yes			
Dial 5	Dial 6	Dial 7	Dial 8	Dial 9

Dial Pad keys



Default

No = SLT

Yes = Voice Mail

5. Press the TRF key; the entered data is written and the data for the next Tel Port No. is displayed.
6. After entering the desired data for the last Tel Port No., press the TRF key to write the data and advance to Memory Block 4-08 (Distinctive Ringing Tone to Telephone Selection).
7. Press the SPKR key to go back on-line.

■ Additional Programming

None

GENERAL INFORMATION - VOICE MAIL/SLT SELECTION

This Memory Block specifies whether an SLT port is used as Voice Mail or a Standard Single Line Telephone.

DISTINCTIVE RINGING TONE TO TELEPHONE SELECTION

Telephone	Data No.
4	08

OPERATION:

1. Go off-line.

2. Enter: Mode Telephone LK 4



3. Enter: Data No. 0 8
(Dial Pad)

Tel Port No. (01~16)	Data No.	Title	Setting Data
0 1 /	0 8	: RNG TONE	= L

T I M E		D I S P L A Y	

4. Press the corresponding Dial Pad key to change the Setting Data option.

- To change Low to High, press Dial Pad key 2.

Dial 0	Dial 1	Dial 2	Dial 3	Dial 4
Low (L)	Medium (M)	High (H)		
Dial 5	Dial 6	Dial 7	Dial 8	Dial 9

Dial Pad keys Default

5. Press the TRF key; the entered data is written and the data for the next Tel Port No. is displayed.
6. After entering the desired data for the last Tel Port No., press the TRF key to write the data and advance to Memory Block 4-09 (3-Minute Alarm Selection).
7. Press the SPKR key to go back on-line.

■ Additional Programming

Mode	Data No.	System Data	
		Required	May Be Required
System (LK 1)	28		√

GENERAL INFORMATION - DISTINCTIVE RINGING TONE TO TELEPHONE SELECTION

This Memory Block specifies the ring tone frequency for each telephone in the system as Low, Medium, or High.

3-MINUTE ALARM SELECTION

Telephone	Data No.
4	09

OPERATION:

1. Go off-line.

2. Enter: Mode Telephone LK 4



3. Enter: Data No. 0 9
(Dial Pad)

Tel Port No. (01~16)	Data No.	Title	Setting Data
0 1 /	09	: 3 m ALM	NO
-----		-----	
TIME		DISPLAY	

NOTES:

1. An approximately one second warning tone sounds every three minutes during CO/PBX calls.

4. Press the corresponding Dial Pad key to change the Setting Data option.

- To change No to Yes, press Dial Pad key 1.

Dial 0	Dial 1	Dial 2	Dial 3	Dial 4
No	Yes			
Dial 5	Dial 6	Dial 7	Dial 8	Dial 9

Dial Pad keys



Default

5. Press the TRF key; the entered data is written and the data for the next Tel Port No. is displayed.
6. After entering the desired data for the last Tel Port No., press the TRF key to write the data and advance to Memory Block 4-10 (HFU Selection).
7. Press the SPKR key to go back on-line.

■ Additional Programming

None

GENERAL INFORMATION - 3-MINUTE ALARM SELECTION

This Memory Block specifies whether or not a warning tone is generated at 3-minute intervals during an outgoing or incoming call.

HFU SELECTION

Telephone	Data No.
4	10

OPERATION:

1. Go off-line.

2. Enter: Mode Telephone LK 4



3. Enter: Data No. 1 0
(Dial Pad)

Tel Port No. (01~16)	Data No.	Title	Setting Data
0 1 /	10	HFU	NO

TIME		DISPLAY	

4. Press the corresponding Dial Pad key to change the Setting Data option.

- To change No to Yes, press Dial Pad key 1.

Dial 0	Dial 1	Dial 2	Dial 3	Dial 4
No	Yes			
Dial 5	Dial 6	Dial 7	Dial 8	Dial 9

Dial Pad keys Default

No = Handsfree Unit not operational
Yes = Handsfree Unit operational

5. Press the **TRF** key; the entered data is written and the data for the next Tel Port No. is displayed.
6. After entering the desired data for the last Tel Port No., press the **TRF** key to write the data and advance to Memory Block 4-11 (Headset Connection Selection).
7. Press the **SPKR** key to go back on-line.

■ **Additional Programming**

None

GENERAL INFORMATION - HFU SELECTION

This Memory Block enables the built-in Handsfree Unit on a per-station basis.

HEADSET CONNECTION SELECTION

Telephone	Data No.
4	11

OPERATION:

1. Go off-line.

2. Enter: Mode Telephone LK 4



3. Enter: Data No. 1 1

(Dial Pad)

Tel Port No. (01~16)	Data No.	Title	Setting Data

01	/	11	:	HEADSET	NO

TIME			DISPLAY		

4. Press the corresponding Dial Pad key to change the Setting Data option.

- To change No to Yes, press Dial Pad key 1.

Dial 0	Dial 1	Dial 2	Dial 3	Dial 4
No	Yes			
Dial 5	Dial 6	Dial 7	Dial 8	Dial 9

Dial Pad keys

Default

5. Press the TRF key; the entered data is written and the data for the next Tel Port No. is displayed.
6. After entering the desired data for the last Tel Port No., press the TRF key to write the data and advance to Memory Block 4-12 (Prime Line Assignment).
7. Press the SPKR key to go back on-line.

■ Additional Programming

None

GENERAL INFORMATION - HEADSET CONNECTION SELECTION

This Memory Block specifies whether or not a headset is connected to the Multiline Terminal.

PRIME LINE ASSIGNMENT

Telephone	Data No.
4	12

OPERATION:

1. Go off-line.

2. Enter: Mode Telephone LK 4



3. Enter: Data No. 1 2

(Dial Pad)

Tel Port No. (01~16)	Data No.	Title	Setting Data
0 1 /	12	: PRILN	= NON
TIME	DISPLAY		

4. Press the corresponding Dial Pad key to change the Setting Data option.

- To change Non to Trunk 2, press Dial Pad key 2.

Dial 0	Dial 1	Dial 2	Dial 3	Dial 4
Non	TK 1	TK 2	TK 3	TK 4
Dial 5	Dial 6	Dial 7	Dial 8	Dial 9
TK 5	TK 6	TK 7	TK 8	

Dial Pad keys



Default

5. Press the TRF key; the entered data is written and the data for the next Tel Port No. is displayed.
6. After entering the desired data for the last Tel Port No., press the TRF key to write the data and advance to Memory Block 4-13 (Attendant Group Selection).
7. Press the SPKR key to go back on-line.

■ Additional Programming

None

GENERAL INFORMATION - PRIME LINE ASSIGNMENT

This Memory Block enables the user to seize a specified trunk when going off-hook.

ATTENDANT GROUP SELECTION

Telephone	Data No.
4	13

OPERATION:

1. Go off-line.

2. Enter: Mode Telephone LK 4



3. Enter: Data No. 1 3
(Dial Pad)

Tel Port No. (01~16)	Data No.	Title	Setting Data
01 /	13 :	ATT	ATT1

TIME		DISPLAY	

4. Press the corresponding Dial Pad key to change the Setting Data option.

- To change ATT1 to ATT2, press Dial Pad key 1.
- ATT1: Attendant Position Tel Port No. 1.
- ATT2: Attendant Position Tel Port No. 2.

Dial 0	Dial 1	Dial 2	Dial 3	Dial 4
ATT 1	ATT 2			
Dial 5	Dial 6	Dial 7	Dial 8	Dial 9

Dial Pad keys Default

5. Press the TRF key; the entered data is written and the data for the next Tel Port No. is displayed.
6. After entering the desired data for the last Tel Port No., press the TRF key to write the data and advance to Memory Block 4-14 (Voice Call Block Selection).
7. Press the SPKR key to go back on-line.

■ Additional Programming

None

GENERAL INFORMATION - ATTENDANT GROUP SELECTION

This Memory Block associates a station with a particular Attendant Position.

VOICE CALL BLOCK SELECTION

Telephone	Data No.
4	14

OPERATION:

NOTES:

1. Go off-line.

2. Enter: Mode Telephone LK 4



3. Enter: Data No. 1 4
(Dial Pad)

1. When voice calls are set as block, incoming internal calls send a ring tone.

Tel Port No. (01~16)	Data No.	Title	Setting Data
00 /	14 :	V/RG	NO

TIME		DISPLAY	

4. Press the corresponding Dial Pad key to change the Setting Data option.

- To change No to Yes, press Dial Pad key 1.

Yes: Tone call only
No: Voice/Tone call

Dial 0	Dial 1	Dial 2	Dial 3	Dial 4
No	Yes			
Dial 5	Dial 6	Dial 7	Dial 8	Dial 9

Dial Pad keys

Default

5. Press the TRF key; the entered data is written and the data for the next Tel Port No. is displayed.
6. After entering the desired data for the last Tel Port No., press the TRF key to write the data and advance to Memory Block 4-15 [CO/PBX Ring Assignment (Day Mode)].
7. Press the SPKR key to go back on-line.

■ Additional Programming

None

GENERAL INFORMATION - VOICE CALL BLOCK SELECTION

This Memory Block blocks stations from receiving voice announced calls.

CO/PBX RING ASSIGNMENT (DAY MODE)

Telephone	Data No.
4	15

OPERATION:

1. Go off-line.

2. Enter: Mode Telephone LK 4



3. Enter: Data No. 1 5
(Dial Pad)

Tel Port No. (01~16)	Data No.	Title	Setting Data
01 /	15	:	DY 12345678
-----		TIME DISPLAY	

4. Press the corresponding Dial Pad key (1~8) to change the Setting Data option.
- The LCD indication changes to indicate the data each time a Dial Pad key is pressed.
 - If the Setting Data number appears on the LCD display, then an incoming call from the corresponding CO/PBX line rings at the indicated station (1~16).

Setting Data: Dial 1~8 (Trunk No.)

Default	Telephones connected to port numbers 01 and 02 ring on all incoming CO/PBX calls.
	Telephones connected to port numbers 03~16 do not ring on any incoming CO/PBX calls.

5. Press the TRF key; the entered data is written and the data for the next Tel Port No. is displayed.
6. After entering the desired data for the last Tel Port No., press the TRF key to write the data and advance to Memory Block 4-16 [CO/PBX Ring Assignment (Night Mode)].
7. Press the SPKR key to go back on-line.

- Additional Programming
None

GENERAL INFORMATION - CO/PBX RING ASSIGNMENT (DAY MODE)

This Memory Block assigns Multiline Terminals to ring on incoming CO/PBX calls in the Day Mode.

CO/PBX RING ASSIGNMENT (NIGHT MODE)

Telephone	Data No.
4	16

OPERATION:

1. Go off-line.

2. Enter: Mode Telephone LK 4



3. Enter: Data No. 1 6
(Dial Pad)

Tel Port No. (01~16)	Data No.	Title	Setting Data
0 2 /	16 :	NT	12345678

TIME		DISPLAY	

4. Press the Dial Pad key corresponding to each CO/PBX number.

- The LCD indication changes to indicate the data each time a Dial Pad key is pressed.
- If the Setting Data number appears on the LCD display, then an incoming call from the corresponding CO/PBX line rings at the indicated station (01~16).

Setting Data: 1 ~ 8 (Trunk No.)

Default	Telephones connected to port numbers 01 and 02 ring on all incoming CO/PBX calls. Telephones connected to port numbers 03~16 do not ring on any incoming CO/PBX calls.
---------	---

5. Press the TRF key; the entered data is written and the data for the next Tel Port No. is displayed.
6. After entering the desired data for the last Tel Port No., press the TRF key to write the data and advance to Memory Block 4-17 [Doorphone Chime Assignment (Day Mode)].
7. Press the SPKR key to go back on-line.

- Additional Programming
None

GENERAL INFORMATION - CO/PBX RING ASSIGNMENT (NIGHT MODE)

This Memory Block assigns Multiline Terminals to ring on incoming CO/PBX calls in the Night Mode.

DOORPHONE CHIME ASSIGNMENT (DAY MODE)

Telephone	Data No.
4	17

OPERATION:

1. Go off-line.

2. Enter: Mode Telephone LK 4



3. Enter: Data No. 1 7
(Dial Pad)

Tel Port No. (01~16)	Data No.	Doorphone Title	No. 1~2	Setting Data
0 2 /	17 :	DYDPH	1	YS

TIME		DISPLAY		

4. Press the corresponding Dial Pad key to change the Setting Data option.

- To change Yes to No, press Dial Pad key 0.

Dial 0	Dial 1	Dial 2	Dial 3	Dial 4
No	Yes			
Dial 5	Dial 6	Dial 7	Dial 8	Dial 9

Dial Pad keys

No = No Chime
Yes = Chime

Default	Yes Telephones connected to port numbers 01 and 02 ring on all Doorphone calls. No Telephones connected to port numbers 03~16 do not ring on any Doorphone calls.
---------	--

5. Press the TRF key; the entered data is written and the data for the next Doorphone No./Tel Port No. is displayed.

NOTES:

1. Single Line Telephones can be set, but do not chime.

6. After entering the desired data for the last Doorphone No./Tel Port No., press the TRF key to write the data and advance to Memory Block 4-18 [Doorphone Chime Assignment (Night Mode)].
7. Press the SPKR key to go back on-line.

- Additional Programming
None

GENERAL INFORMATION - DOORPHONE CHIME ASSIGNMENT (DAY MODE)

This Memory Block assigns which stations chime on a Doorphone call when the system is in the Day Mode.

DOORPHONE CHIME ASSIGNMENT (NIGHT MODE)

Telephone	Data No.
4	18

OPERATION:

1. Go off-line.
2. Enter: Mode Telephone LK 4
- ▼
3. Enter: Data No. 1 8
(Dial Pad)

Tel Port No. (01~16)	Data No.	Doorphone Title	No. 1~2	Setting Data
0 2 /	18 :	NTDPH	1	YS

TIME		DISPLAY		

4. Press the corresponding Dial Pad key to change the Setting Data option.
 - To change Yes to No, press Dial Pad key 0.

Dial 0	Dial 1	Dial 2	Dial 3	Dial 4
No	Yes			
Dial 5	Dial 6	Dial 7	Dial 8	Dial 9

Dial Pad keys

No = No Chime
Yes = Chime

Default	Yes Telephones connected to port numbers 01 and 02 ring on all Doorphone calls No Telephones connected to port numbers 03~16 do not ring on any Doorphone calls.
---------	---

NOTES:

1. Single Line Telephones can be set, but do not chime.

5. Press the TRF key; the entered data is written and the data for the next Doorphone No./Tel Port No. is displayed.
6. After entering the desired data for the last Doorphone No./Tel Port No., press the TRF key to write the data and advance to Memory Block 4-19 [Station to Class of Service Feature Assignment (Day Mode)].
7. Press the SPKR key to go back on-line.

- Additional Programming
- None

GENERAL INFORMATION - DOORPHONE CHIME ASSIGNMENT (NIGHT MODE)

This Memory Block assigns which stations chime on a Doorphone call when the system is in Night Mode.

STATION TO CLASS OF SERVICE FEATURE ASSIGNMENT (DAY MODE)

Telephone	Data No.
4	19

OPERATION:

1. Go off-line.

2. Enter: Mode Telephone LK 4



3. Enter: Data No. 1 9
(Dial Pad)

Tel Port No. (01~16)	Data No.	Title	Setting Data 0~7
0 2 /	19 :	DYCLASS	0

TIME		DISPLAY	

4. Press the corresponding Dial Pad key to change the Setting Data option.

- To change Class 1 to Class 2, press Dial Pad key 2.

Dial 0	Dial 1	Dial 2	Dial 3	Dial 4
Class 0	Class 1	Class 2	Class 3	Class 4
Dial 5	Dial 6	Dial 7	Dial 8	Dial 9
Class 5	Class 6	Class 7		

Dial Pad keys

Default

Default	Port Numbers 01 and 02: Class 0 Port Numbers 03 ~ 16: Class 1
---------	--

5. Press the TRF key; the entered data is written and the data for the next Tel Port No. is displayed.
6. After entering the desired data for the last Tel Port No., press the TRF key to write the data and advance to Memory Block 4-20 [Station to Class of Service Feature Assignment (Night Mode)].
7. Press the SPKR key to go back on-line.

■ Additional Programming

Mode	Data No.	System Data	
		Required	May Be Required
System (LK1)	55		✓

GENERAL INFORMATION - STATION TO CLASS OF SERVICE FEATURE ASSIGNMENT (DAY MODE)

This Memory Block specifies the class to enable or disable features during the Day Mode on a per-station basis.

STATION TO CLASS OF SERVICE FEATURE ASSIGNMENT (NIGHT MODE)

Telephone	Data No.
4	20

OPERATION:

1. Go off-line.

2. Enter: Mode Telephone LK 4



3. Enter: Data No. 2 0

(Dial Pad)

Tel Port No. (01~16)	Data No.	Title	Setting Data
0 /	20 :	NT CLASS	0

TIME		DISPLAY	

4. Press the corresponding Dial Pad key to change the Setting Data option.

- To change Class 1 to Class 2, press Dial Pad key 2.

Dial 0	Dial 1	Dial 2	Dial 3	Dial 4
Class 0	Class 1	Class 2	Class 3	Class 4
Dial 5	Dial 6	Dial 7	Dial 8	Dial 9
Class 5	Class 6	Class 7		

Dial Pad keys

Default	Port Numbers 01 and 02: Class 0
	Port Numbers 03 ~ 16: Class 1

5. Press the TRF key; the entered data is written and the data for the next Tel Port No. is displayed.

6. After entering the desired data for the last Tel Port No., press the TRF key to write the data and advance to Memory Block 4-21 [Code Restriction Class Assignment (Day Mode)].

7. Press the SPKR key to go back on-line.

NOTES:

1. Refer to System Mode, Memory Block 1-55 (Class of Service Feature Selection).

■ Additional Programming

Mode	Data No.	System Data	
		Required	May Be Required
System (LK1)	55		√

GENERAL INFORMATION - STATION TO CLASS OF SERVICE FEATURE ASSIGNMENT (NIGHT MODE)

This Memory Block specifies the class to enable or disable features during the Night Mode on a per-station basis.

CODE RESTRICTION CLASS ASSIGNMENT (DAY MODE)

Telephone	Data No.
4	21

OPERATION:

1. Go off-line.

2. Enter: Mode Telephone LK 4



3. Enter: Data No. 2 | 1
(Dial Pad)

Tel Port No. (01~16)	Data No.	Title	Setting Data
0 1 /	2 1	DAY REST	0

TIME		DISPLAY	

4. Press the corresponding Dial Pad key to change the Setting Data option.

- To change Class 1 to Class 2, press Dial Pad key 2.

Dial 0	Dial 1	Dial 2	Dial 3	Dial 4
Class 0	Class 1	Class 2	Class 3	Class 4
Dial 5	Dial 6	Dial 7	Dial 8	Dial 9
Class 5	Class 6	Class 7		

Dial Pad keys

Default	Port Numbers 01 ~ 16 Class 0
---------	---------------------------------

5. Press the TRF key; the entered data is written and the data for the next Tel Port No. is displayed.
6. After entering the desired data for the last Tel Port No., press the TRF key to write the data and advance to Memory Block 4-22 [Code Restriction Class Assignment (Night Mode)].
7. Press the SPKR key to go back on-line.

■ Additional Programming

Mode	Data No.	System Data	
		Required	May Be Required
System (LK3)	55		✓
System (LK1)	56		✓
System (LK1)	58		✓

GENERAL INFORMATION - CODE RESTRICTION CLASS ASSIGNMENT (DAY MODE)

This Memory Block specifies Code Restriction Class in Day Mode on a per-station basis.

CODE RESTRICTION CLASS ASSIGNMENT (NIGHT MODE)

Telephone	Data No.
4	22

OPERATION:

1. Go off-line.

2. Enter: Mode Telephone LK 4



3. Enter: Data No. 2 2
(Dial Pad)

Tel Port No. (01~16)	Data No.	Title	Setting Data
0 1 /	22 :	NT REST	0

TIME		DISPLAY	

4. Press the corresponding Dial Pad key to change the Setting Data option.

- To change Class 0 to Class 2, press Dial Pad key 2.

Dial 0	Dial 1	Dial 2	Dial 3	Dial 4
Class 0	Class 1	Class 2	Class 3	Class 4
Dial 5	Dial 6	Dial 7	Dial 8	Dial 9
Class 5	Class 6	Class 7		

Dial Pad keys

Default	Port Numbers 01 ~ 16: Class 0
---------	-------------------------------

5. Press the TRF key; the entered data is written and the data for the next Tel Port No. is displayed.
6. After entering the desired data for the last Tel Port No., press the TRF key to write the data and advance to Memory Block 4-23 (Trunk Digit Restriction).
7. Press the SPKR key to go back on-line.

■ Additional Programming

Mode	Data No.	System Data	
		Required	May Be Required
System (LK 1)	55		✓
System (LK 1)	56		✓
System (LK 1)	58		✓

GENERAL INFORMATION - CODE RESTRICTION CLASS ASSIGNMENT (NIGHT MODE)

This Memory Block specifies Code Restriction Class in Night Mode on a per-station basis.

TRUNK DIGIT RESTRICTION

Telephone	Data No.
4	23

OPERATION:

1. Go off-line.

2. Enter: Mode Telephone LK 4



3. Enter: Data No. 2 3
(Dial Pad)

Tel No. (01~16)	Data No.	Title	Setting Data
0 1 /	23	REST DIG	=00

TIME		DISPLAY	

4. Enter the data using the Dial Pad.

Setting Data: 00, 01~99 digits
(00: No Limit)

Default	00 (No Limit)
---------	---------------

5. Press the TRF key; the entered data is written and the data for the next Tel Port No. is displayed.
6. After entering the desired data for the last Tel Port No., press the TRF key to write the data and advance to Memory Block 4-24 (Automated Attendant Delay Ring Assignment).
7. Press the SPKR key to go back on-line.

■ Additional Programming

Mode	Data No.	System Data	
		Required	May Be Required
Telephone (LK4)	21		✓
Telephone (LK4)	22		✓

GENERAL INFORMATION - TRUNK DIGIT RESTRICTION

This Memory Block specifies, on a per-station basis, the maximum number of digits that can be dialed while on an outside line.

NOTES:

This feature has no effect on a station assigned to Code Restriction Class 0 or 7 in Memory Blocks 4-21 [Code Restriction Class Assignment (Day Mode)] and 4-22 [Code Restriction Class Assignment (Night Mode)].

AUTOMATED ATTENDANT DELAY RING ASSIGNMENT

Telephone	Data No.
4	24

OPERATION:

1. Go off-line.

2. Enter: Mode Telephone LK 4

3. Enter: Data No. 2 | 4
(Dial Pad)

Tel Port No. (01~16)	Data No.	Title	Setting Data
01 /	24	: AR	12345678

TIME		DISPLAY	

4. Press the corresponding Dial Pad key (1~8) to change the Setting Data option.

- The LCD indication changes to indicate the data each time a Dial Pad key is pressed.
- If the Setting Data number appears on the LCD display, then an incoming call from the corresponding CO/PBX line rings at the indicated station (1~16).

Setting Data: Dial 1~8 (Trunk No.)

Default	Telephones connected to Port Nos 01 and 02 ring on all incoming CO/PBX calls. Telephones connected to Port Nos 03~16 do not ring on any incoming CO/PBX calls.
---------	---

5. Press the TRF key; the entered data is written and the data for the next Tel Port No. is displayed.

6. After entering the desired data for the last Tel Port No., press the TRF key to write the data and advance to Memory Block 4-01 (SLT Connected Yes/No Selection).

7. Press the SPKR key to go back on-line.

NOTES:

1. The ringing assignment is in effect for both Day and Night Modes.
2. System software version 1.5 or higher is required to support the Automated Attendant feature.

■ **Additional Programming**

Refer to Section 6 - Guide to Feature Programming in this chapter.

GENERAL INFORMATION - AUTOMATED ATTENDANT DELAY RING ASSIGNMENT

This Memory Block assigns which station(s) the incoming CO/PBX line(s) is transferred to (by the Automated Attendant) when the call is not answered within the preselected time.

ROM VERSION CONFIRMATION

Special	Data No.
FNC	1

OPERATION:

1. Go off-line.

2. Enter: Mode Special



3. Enter: Data No.
(Dial Pad)

Title		Version
0	CPU	= 2.0

TIME	DISPLAY	

Item	
0	CPU
1	MMC
2	COI
3	SMDR
4	PBR
5	VRS (version 1.5 or higher)
6	2COI (version 3.0 or higher)

4. Press the TRF key to display the version of the next item.

5. Press the SPKR key to go back on-line.

GENERAL INFORMATION - ROM VERSION CONFIRMATION

This Memory Block confirms the version of ROM installed in the system.

SYSTEM SPEED DIAL MEMORY CLEAR

Special	Data No.
FNC	2

OPERATION:

1. Go off-line.
2. Enter: Mode Special
3. Enter: Data No.

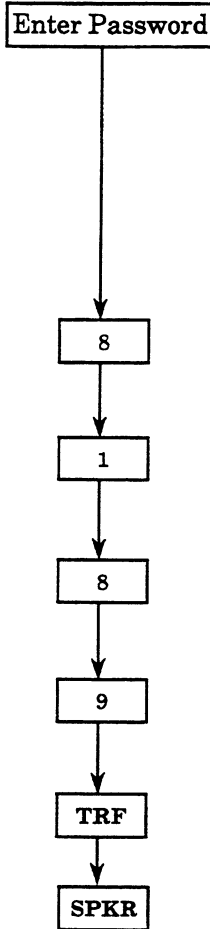
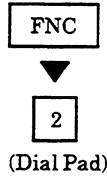

CLR	SYS	SPD?

TIME	DISPLAY	

Use Dial Pad [0] ~ [9] : To enter password

WARNING

Before performing this procedure, completely understand implications of erasing all System Speed Dial buffers in the system.

NOTES:

1. Areas to be erased:
 - Speed Dial numbers 20~99.

GENERAL INFORMATION - SYSTEM SPEED DIAL MEMORY CLEAR

This Memory Block clears all System Speed Dial programming in the system.

STATION SPEED DIAL MEMORY CLEAR

Special	Data No.
FNC	3

OPERATION:

1. Go off-line.

2. Enter: Mode Special

FNC

3. Enter: Data No.

3
(Dial Pad)

CLR	TEL	SPD?

TIME	DISPLAY	

Dial pad 0 ~ 9 : To enter password

Enter Password

8

2

9

9

TRF

SPKR

WARNING

Before performing this procedure, completely understand implications of erasing all System Speed Dial buffers in the system.

NOTES:

- Areas to be erased:
 - Speed Dial numbers 00~19.

GENERAL INFORMATION - STATION SPEED DIAL MEMORY CLEAR

This Memory Block clears all Station Speed Dial programming from the system.

SYSTEM DATA MEMORY INITIALIZE OPERATION

Special	Data No.
FNC	4

OPERATION:

1. Go off-line.
2. Enter: Mode Special
3. Enter: Data No.

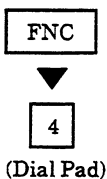

CLR	SYSTEM	DATA

TIME	DISPLAY	

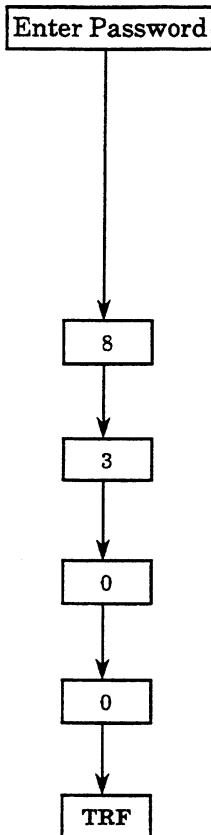

Dial pad ~ : To enter password

WARNING

Before performing this procedure, completely understand implications of erasing all Program Data in the system.

GENERAL INFORMATION - SYSTEM DATA MEMORY INITIALIZE OPERATION
 This Memory Block initializes System Data memories of all programmed System Data and returns the system to the default program.

CLOCK/CALENDAR SETTING

OPERATION:

FNC



9

(Dial Pad)



#

(Dial Pad)

11:08 AM	

TIME	DISPLAY

← [*] [#] → : To move cursor

Dial pad [0] ~ [9] : To enter Time, Date, Month, Year

RECALL key : To switch a.m./p.m.
To switch month and weekdays

- Move the cursor to the data to be modified.
- Enter the new data using the Dial Pad.
- Press the **RECALL** key to switch a.m./p.m.
- Press the **HOLD** key to set the Year, Month, and Day.

(Refer to the example on the next page.)

NOTES:

1. This is a station operation performed by the Attendant station.

GENERAL INFORMATION - CLOCK/CALENDAR SETTING

This Memory Block programs the year, month, day, hour, and minute, and a.m. or p.m.

EXAMPLE:

To change the time and date to 12:00 p.m. Sunday, December 31, 1992:

```

  11:08 AM
-----
  TIME DISPLAY

```

- Using the Dial Pad, press 1 2 0 0.

```

  12:00 AM
-----
  TIME DISPLAY

```

- Press the **RECALL** key.

```

  12:00 PM
-----
  TIME DISPLAY

```

- Press the **HOLD** key.

```

  MON   01   JAN   1991
-----
  TIME DISPLAY

```

- Press the **RECALL** key, and select **SUN**.

```

  SUN   01   JAN   1991
-----
  TIME DISPLAY

```

- Move the cursor to the 01 position.

```

  SUN   01   JAN   1991
-----
  TIME DISPLAY

```

- Using the Dial Pad, press 3 1.

```

  SUN   31   JAN   1991
-----
  TIME DISPLAY

```

- Press the **RECALL** key, and select **DEC**.

```

  SUN   31   DEC   1991
-----
  TIME DISPLAY

```

- Move the cursor to the 1991 position

```

  SUN   31   DEC   1991
-----
  TIME DISPLAY

```

- Using the Dial Pad, press 9 2.

```

  SUN   31   DEC   1992
-----
  TIME DISPLAY

```

- Press the **FNC** key.

```

-----
  TIME DISPLAY

```

SECTION 5 FUNCTION TIMER CHART

Function Timer Chart

Timer	Memory Block	Definition	Timing Value		
			Min.	Default	Max.
Hookflash Time Selection (Multiline Terminal)	1-01	The break time for a hookflash signal (that breaks the DC loop of a CO/PBX line) sent to the CO or PBX when the RECALL key on a Multiline Terminal is pressed.	60 ms.	600 ms.	2 sec.
Hold Recall Timer Selection (Non-Exclusive)	1-02	The interval of a held CO/PBX call until a recall tone is generated. If "No Limit" is selected, no hold alarm tone is generated.	1 min.	1 min.	No Limit
Exclusive Hold Recall Timer Selection	1-03	The interval for Exclusive Hold Recall tone. If "No Limit" is selected, no Exclusive Hold tone is provided.	1 min.	1 min.	No Limit
Internal/External Paging Access Time Selection	1-04	The time allowed for paging.	90 sec.	90 sec.	No Limit
Trunk Queuing Recall Time Selection	1-05	The time an outgoing CO/PBX line rings at the station where the queue was set, before the queue is automatically canceled.	10 sec.	10 sec.	60 sec.
Pause Time Selection	1-06	The length of the pause inserted between digits dialed on CO/PBX lines.	1 sec.	3 sec.	3 sec.
DP Interdigit Time Selection	1-07	The minimum length of the pause interval between Dial Pulse dialing.	650/500 ms.	800/800 ms.	800/800 ms.
Receiver (PBR) Release Timer Selection	1-08	The interval during which a receiver circuit is connected to a DTMF type Single Line Telephone waiting for each digit to be dialed.	5 sec.	10 sec.	60 sec.
Doorphone Display Time Selection	1-09	The duration of an incoming Doorphone call indication displayed at a Multiline Terminal.	10 sec.	10 sec.	90 sec.
CO Transfer Recall Timer Selection	1-10	The interval from ringing tone transfer until a recall tone is generated to the originating telephone if the call is not answered.	30 sec.	60 sec.	240 sec.
Automatic Callback Time Selection	1-11	The time allowed for an Automatic Callback to occur before the request is automatically canceled.	30 min.	No Limit	No Limit
Automatic Redial Time Selection	1-12	The call time, wait time, and number of attempts for an automatic redial. (Call Time/Wait Time/Attempts)	15 sec. 60 sec. 5 times	15 sec. 60 sec. 5 times	30 sec. 120 sec. 5 times
Bounce Protect Time Selection	1-13	The time before a valid hookflash can be detected from a Single Line Telephone or Voice Mail system.	0 ms.	300 ms.	900 ms.
Hookflash Start Time Selection	1-14	Specifies the minimum hookflash duration from a Single Line Telephone.	100 ms.	300 ms.	850 ms.
Hookflash End Time Selection	1-15	Specifies a maximum duration from a Single Line Telephone to receive a dial tone. HST = Hookflash Start Time	HST + 0	HST + 700 ms.	HST + 1500 ms.

Function Timer Chart (continued)

Timer	Memory Block	Definition	Timing Value		
			Min.	Default	Max.
Call Forward Busy/No Answer Timer Selection	1-16	The time before incoming ICM calls or CO/PBX lines are forwarded to another station number when the called party does not answer.	10 sec.	10 sec.	60 sec.
Trunk-to-Trunk Transfer Automatic Disconnect Time Selection	1-17	The maximum time before an automatic disconnect of Trunk-to-Trunk connections occurs.	30 min.	1 hr.	3 hr.
Elapsed Call and SMDR Start Timer Selection	1-18	The interval after dialing until the start of call duration display.	10 sec.	10 sec.	30 sec.
Disconnect Time Selection	1-19	The minimum time for a circuit that has been disconnected until it can be accessed again.	0.3 sec.	1.5 sec.	4.0 sec.
Automatic Release Disconnection Signal Detection Time Selection	1-20	The signal detection time for release of a CO/PBX line when a disconnect signal is received from the distant CO/PBX.	0.5 ms.	350 ms.	500 ms.
Time Display (12h/24h) Selection	1-26	Specifies either a 12-hour or 24-hour time.	12 hr.	12 hr.	24 hr.
Voice Mail DTMF Delay Timer Selection	1-68	The length of delay before DTMF tones are sent to Voice Mail ports.	0 sec.	1.0 sec.	14 sec.
Voice Mail DTMF Duration/Interdigit Time Selection	1-69	Used to specify the DTMF duration and Interdigit time for Voice Mail.	70/60 ms.	100/70 ms.	900/200 ms.
System Refresh Timer Selection	1-70	The time all terminals are idle before the system refreshes itself.	No Refresh	4 hr.	24 hr.
VRS/VM Automated Attendant Answer Delay Time Assignment	1-72	The time before an incoming CO/PBX call is answered by the Automated Attendant.	0 sec.	3 sec.	48 sec.
VRS/VM Automated Attendant PBR Release Timer Selection	1-73	The time an Automated Attendant remains connected when a calling party is dialing.	0 sec.	20 sec.	60 sec.
VRS/VM Automated Attendant Delay Ringing Time Selection	1-74	Specifies the time before the Automated Attendant changes to CO/PBX ringing when a transferred call is not answered.	10 sec.	∞	30 sec.
Automated Attendant No Answer Disconnect Time Selection	1-75	The time an Automated Attendant rings a station before disconnecting the caller.	1 min.	1 min.	∞
Fax Line Reservation Timer Selection	1-78	The time the CO/PBX line is reserved exclusively for the fax connection.	30 sec.	30 sec.	240 sec.
CO/PBX DTMF Duration/Interdigit Assignment	3-07	Used to specify the tone duration and interdigit time of DTMF signals.	70/60 ms.	70/60 ms.	900/200 ms.
DP Dial Make Ratio Selection	03-17	Used to select the make ratio for Dial Pulse lines.	33%	39%	39%

SECTION 6 GUIDE TO FEATURE PROGRAMMING

This section lists features that may require programming of specific Memory Blocks in order to use these features properly. Features are listed in alphabetic order, and the associated Memory Blocks for each feature are listed in numeric order.

An asterisk (*) is used to indicate the Memory Blocks that must be programmed before the feature can be used. The other Memory Blocks listed for a feature may have to be programmed, depending on the user's application.

Ancillary Device Connection Memory Blocks

Headset Connection Selection 4-11

Attendant Positions Memory Blocks

Class of Service Feature Selection (Feature 00) 1-55

Station to Class of Service Feature Assignment (Day Mode) 4-19

Station to Class of Service Feature Assignment (Night Mode) 4-20

Automatic Day/Night Mode Switching Memory Blocks

Day/Night Mode Switching Time Assignment 1-27

Automatic Redial

Automatic Redial Time Selection 1-12

Background Music - External Speaker Memory Blocks

* BGM Selection 1-22

External Speaker Connection Selection 1-30

Background Music - Multiline Speaker Memory Blocks

* BGM Selection 1-22

Barge-In

Barge-In Alert Tone Assignment 1-29

Barge-In Class of Service Feature Selection 1-55

Call Forward Busy/No Answer Memory Blocks

Call Forward Busy/No Answer Timer Selection 1-16

Class of Service Feature Selection (Features 00 & 07) 1-55

Station to Class of Service Feature Assignment (Day Mode) 4-19

Station to Class of Service Feature Assignment (Night Mode) 4-20

Call Transfer Memory Blocks

CO Transfer Recall Timer Selection	1-10
Ring Transfer Selection	1-25
SLT Hookflash Signal Selection	1-34
SLT Transfer Selection	1-64

Class of Service Memory Blocks

Class of Service Feature Selection	1-55
Station to Class of Service Feature Assignment (Day Mode)	4-19
Station to Class of Service Feature Assignment (Night Mode)	4-20

Code Restriction Memory Blocks

Refer to Section 7 of this chapter.

Dial 0 for Attendant Memory Blocks

Attendant Group Selection	4-13
---------------------------------	------

Door Lock Release Memory Blocks

* General Purpose Relay Assignment	1-48
--	------

Door/Monitor Phone Memory Blocks

Doorphone Display Time Selection	1-09
Doorphone Connection Selection	1-33
Doorphone Preference Selection	1-45
System Refresh Timer Selection	1-70
Doorphone Chime Assignment (Day Mode)	4-17
Doorphone Chime Assignment (Night Mode)	4-18

External Paging (Meet-Me) Memory Blocks

Internal/External Paging Access Time Selection	1-04
BGM Selection	1-22
External Speaker Connection Selection	1-30
General Purpose Relay Assignment	1-48
Class of Service Feature Selection (Feature 03)	1-55
Internal/External Paging Alert Tone Selection	1-63
Station to Class of Service Feature Assignment (Day Mode)	4-19
Station to Class of Service Feature Assignment (Night Mode)	4-20

External Ring Control Memory Blocks

* General Purpose Relay Assignment	1-48
* External Ring Selection	1-53
* Night Chime Selection	1-54

External Tone Ringer Via External Speaker Memory Blocks

External Speaker Connection Selection	1-30
* External Ring Selection	1-53

Fax Connection

* General Purpose Relay Assignment	1-48
Fax Line Reservation Timer Selection	1-78

Feature Access Keys - User Programmable Memory Blocks

CO Line Selection (Installed, DP, DTMF)	3-10
---	------

Flexible Line Keys Memory Blocks

CO Line Selection (Installed, DP, DTMF)	3-10
---	------

Flexible Station Numbering Plan Memory Blocks

Station Number Assignment	4-06
---------------------------------	------

General Purpose Relays Memory Blocks

* General Purpose Relay Assignment	1-48
(Refer to each Feature for additional programming.)	

Handsfree Speaker Phone

HFU Selection	4-10
---------------------	------

Headset Connection Via ADA (1)-W (BK)/(SW) Unit Memory Blocks

Headset Connection Selection	4-11
------------------------------------	------

Hold Free Transfer Memory Blocks

* Hold Free Transfer Selection	1-47
--------------------------------------	------

Internal Voice/Tone Signaling Memory Blocks

Voice/Tone Signal Selection	1-21
Voice Call Block Selection	4-14

Internal Zone Paging

Internal Zone Paging Selection	4-03
--------------------------------------	------

Multiple Trunk Groups Memory Blocks

Trunk-to-Trunk Group Assignment	3-11
---------------------------------------	------

Night Chime Memory Blocks

* General Purpose Relay Assignment	1-48
* Night Chime Selection	1-54

Off-Hook Ringing Memory Blocks

Class of Service Feature Selection (Feature 04)	1-55
Station to Class of Service Feature Assignment (Day Mode)	4-19
Station to Class of Service Feature Assignment (Night Mode)	4-20

Prime Line Assignment Memory Blocks

* Prime Line Assignment	4-12
-------------------------------	------

Privacy Release Memory Blocks

Elapsed Call and SMDR Start Timer Selection	1-18
---	------

Private Line

Private Line Assignment	1-32
-------------------------------	------

Restriction (Outgoing) Memory Blocks

* Trunk Status Selection	3-08
* Code Restriction Class Assignment (Day Mode)	4-21
* Code Restriction Class Assignment (Night Mode)	4-22
Trunk Digit Restriction	4-23

Ring Tone Variation Memory Blocks

Distinctive Ringing Tone to Telephone Selection	4-08
CO/PBX Ring Assignment (Day Mode)	4-15
CO/PBX Ring Assignment (Night Mode)	4-16

Ringing Line Preference Memory Blocks

* Ringing Line Preference Selection	4-04
---	------

Room Monitor Terminal Memory Blocks

Class of Service Feature Selection (Features 14 & 15)	1-55
Station to Class of Service Feature Assignment (Day Mode)	4-19
Station to Class of Service Feature Assignment (Night Mode)	4-20

Single Line Telephone Access Memory Blocks

Receiver (PBR) Release Timer Selection	1-08
Bounce Protect Time Selection	1-13
Hookflash Start Time Selection	1-14
Hookflash End Time Selection	1-15
SLT Hookflash Signal Selection	1-34
SLT Transfer Selection	1-64
SLT Connected Yes/No Selection	4-01
DTMF/DP SLT Type Selection	4-05

Speed Dial - System Memory Blocks

System Speed Dial Override Selection	1-23
System Speed Dial Display Station Selection	1-24
Class of Service Feature Selection (Feature 00)	1-55
Station to Class of Service Feature Assignment (Day Mode)	4-19
Station to Class of Service Feature Assignment (Night Mode)	4-20

Station Hunting Memory Blocks

Station Master Hunt Number Selection	1-35
Station Number Assignment	4-06

Tenant Service Memory Blocks

Trunk to Tenant Assignment	2-01
Telephone to Tenant Assignment	4-02

Timed Alarm Memory Blocks

Class of Service Feature Selection (Features 00 & 04)	1-55
Station to Class of Service Feature Assignment (Day Mode)	4-19
Station to Class of Service Feature Assignment (Night Mode)	4-20

Trunk-to-Trunk Transfer

Trunk-to-Trunk Class of Service Feature Selection	1-55
Trunk-to-Trunk Transfer Yes/No Selection	3-14

Unsupervised Conference (Tandem) Memory Blocks

Automatic Release Disconnection Signal Detection Time Selection	1-20
---	------

Voice Mail Integration Memory Blocks

Station Master Hunt Number Selection	1-35
SLT Transfer Selection	1-64
* Voice Mail Access Code Assignment	1-67
Voice Mail DTMF Delay Timer Selection	1-68
Voice Mail DTMF Duration/Interdigit Time Selection	1-69
Station Number Assignment	4-06
* Voice Mail/SLT Selection	4-07
CO/PBX Ring Assignment (Day Mode)	4-15
CO/PBX Ring Assignment (Night Mode)	4-16

Voice Over Split Memory Blocks

Class of Service Feature Selection (Features 12 & 13)	1-55
Station to Class of Service Feature Assignment (Day Mode)	4-19
Station to Class of Service Feature Assignment (Night Mode)	4-20

Voice Recording Service (VRS) Memory Blocks

VRS Message Recording Time Selection	1-37
* VRS Automatic Answer/Automated Attendant (Night) Selection	1-38
* VRS Automatic Answer/Automated Attendant (Day) Selection	1-39
* VRS Automatic Answer/Automated Attendant (Weekend) Selection	1-40
VRS Manual Answer Selection	1-41
VRS Automatic Answer/Automated Attendant (Night) Time Assignment	1-42
VRS Automatic Answer/Automated Attendant (Day) Time Assignment	1-43
VRS Automatic Answer/Automated Attendant (Off) Time Assignment	1-44

Class of Service Feature Selection (Feature 11)	1-55
* VRS Answer Mode Selection	1-71
Automated Attendant Answer Delay Time Assignment	1-72
Automated Attendant PBR Release Timer Selection	1-73
Automated Attendant Delay Ringing Time Selection	1-74
Automated Attendant No Answer Disconnect Time Selection	1-75
Automated Attendant No DTMF Detect Selection	1-76
* Automated Attendant Access Code Assignment	1-77
* VRS Automatic Answer Yes/No Selection	3-15
CO/PBX Ring Assignment (Day Mode)	4-15
CO/PBX Ring Assignment (Night Mode)	4-16
Station to Class of Service Feature Assignment (Day Mode)	4-19
Station to Class of Service Feature Assignment (Night Mode)	4-20
Automated Attendant Delay Ring Assignment	4-24

VRS - Internal Memory Blocks

VRS Message Recording Time Selection	1-37
Class of Service Feature Selection	1-55
Station to Class of Service Feature Assignment (Day Mode)	4-19
Station to Class of Service Feature Assignment (Night Mode)	4-20

VRS - Hold Message

* VRS Hold Message Assignment	3-18
-------------------------------------	------

THIS PAGE INTENTIONALLY LEFT BLANK

SECTION 7 CODE RESTRICTION**7.1 General**

The Electra Professional Level I system provides an advanced method for restricting outgoing calls based on the first eight digits dialed. Code Restriction denies placement of outside calls based on Trunk Groups and accommodates equal access to Other Common Carriers (OCC). This eliminates unauthorized calls and configures system calling functions to provide cost control.

System Programming has eight Code Restriction Classes. Class 0 is fixed and allows free dialing. Class 7 is fixed and denies all outside calls. Classes 1~6 are programmable in system software. Stations are assigned to Code Restriction Class on a per-station basis. A separate Day Mode and Night Mode station to Code Restriction Class assignment is available.

7.2 Default Assignments

- At default, all stations are assigned to Code Restriction Class 0 for both Day and Night modes; this allows free dialing.
- At default, the Code Restriction Classes (listed below) are set up with the specified restrictions to provide the most common Code Restriction requirements and simplify Code Restriction programming.

Class 1: Deny 0 and 1 plus calls

Class 2: Deny 0 and 1 plus calls
Allow 1800 calls

Class 3: Deny 0, 1 plus, and 976 calls
Allow 1800 calls

Class 4: Deny only 1 plus calls
Allow 1800 calls

Classes 5 & 6: Allow only 911 calls

- At default, all OCC calls are denied for Code Restriction Classes 1 ~ 6.
- At default, System Speed Dial buffers 60 ~ 99 do not override Code Restriction for Classes 1 ~ 6.
- At default, Digit Restriction is not assigned.

(Refer to Section 7.5 - Code Restriction Tables in this chapter for additional default values.)

7.3 Memory Blocks

The following is a list of related Memory Blocks used when assigning Code Restriction.

<u>Title</u>	<u>Memory Block</u>
PBX/CTX Access Code Assignment	1-31
Trunk to Tenant Assignment	2-01
CO/PBX Line Code Restriction Override Selection	3-12
Trunk Type Selection	3-09
Trunk-to-Trunk Group Assignment	3-11
8-Digit Matching Table Assignment	1-56
Class Allow/Deny Assignment	1-57
8-Digit Matching Table to Class Assignment	1-58
8-Digit Matching Table to Trunk Group Assignment	1-59
OCC Table Assignment	1-60
OCC Table to Trunk Group Assignment	1-61
8-Digit Matching Table to OCC Table Assignment	1-62
System Speed Dial Override Selection	1-23
Trunk Digit Restriction	4-23
Telephone to Tenant Assignment	4-02
Code Restriction Class Assignment (Day Mode)	4-21
Code Restriction Class Assignment (Night Mode)	4-22

7.4 Memory Block Description

7.4.1 General

This section describes the function of the Memory Blocks that are directly related to Code Restriction. Some Memory Blocks from the list in Section 7.3 - Memory Blocks are not described in this section, but are included on the list because of their indirect effect on Code Restriction (e.g., Trunk to Tenant Assignment).

Code Restriction is based on a Trunk Group basis. Therefore, consideration should be given to Memory Block 1-61 (OCC Table to Trunk Group Assignment) because stations are assigned to a Tenant and trunks are assigned to a Trunk Group.

7.4.2 OCC Assignment/Operation

OCC Table Assignment (Memory Block 1-60)

This Memory Block allows an OCC Access Code (maximum of eight digits) to be assigned. There are 16 OCC Tables (01~16) in System Programming. Each table can have one OCC Access Code assigned.

OCC Table to Trunk Group Assignment (Memory Block 1-61)

This Memory Block assigns Trunk Groups to the OCC Tables. Any combination of Trunk Groups can be assigned to the OCC Tables.

8-Digit Matching Table to OCC Table Assignment (Memory Block 1-62)

This Memory Block assigns the 8-Digit Matching Tables to the OCC Tables. Any combination of 8-Digit Matching Tables can be assigned to the OCC Tables.

OCC Operations

When a restricted station user dials an OCC Access Code, the system searches the OCC Tables for a match. If no match is found, the system searches the 8-Digit Matching Tables. If a match is found, the system monitors the next eight digits dialed and searches the 8-Digit Matching Tables assigned to the OCC Table. The system searches only the 8-Digit Matching Tables assigned to the Code Restriction Class where the station is assigned. The trunks are assigned to the station on a Trunk Group basis. While the station user is dialing on an outside line, the system searches the assigned tables. If the interdigit time duration of the dialing party exceeds 10 seconds, the system automatically drops the call.

7.4.3 8-Digit Matching Table Assignment/Operation**8-Digit Matching Table to Trunk Group Assignment (Memory Block 1-59)**

This Memory Block assigns Trunk Groups to the 8-Digit Matching Tables. Any combination of Trunk Groups can be assigned to the 8-Digit Matching Tables.

8-Digit Matching Table Assignment (Memory Block 1-56)

This Memory Block assigns the 8-Digit Matching Tables. Each 8-Digit Matching Table can have eight, 8-digit entries. To cover the many possible combinations (without listing each individual number), code restriction letters can be used in place of digits. The code restriction letters used and their numerical values are:

X = 0~9, *, and #

P = 0 and 1

N = 2~9

When 1X is entered in a table and the table is assigned as a Deny Table in the 8-Digit Matching Table to Class Assignment, any call (1 + any digit) is denied if the table is used. Using X, P, and N accommodates several combinations with just one entry.

Note: The Trunk Access Code should not be placed in the 8-Digit Matching Table because Code Restriction starts after a trunk is seized.

8-Digit Matching Table to Class Assignment (Memory Block 1-58)

This Memory Block assigns the 8-Digit Matching Tables to the Code Restriction Classes. The 8-Digit Matching Tables are also assigned as Allow/Deny Tables or as Allow/Deny (OCC only) Tables in this Memory Block. A maximum of six, 8-Digit Matching Tables can be assigned to Code Restriction Classes 1~6 (version 2.0 software or lower). Version 2.72 or higher software expands the table entries from a maximum of 6 tables to a maximum of 16 tables per station class. Classes 0 and 7 are fixed and are not programmable.

Class Allow/Deny Assignment

(Memory Block 1-57)

This Memory Block assigns Code Restriction Classes (1~6) as Allow or Deny. This assignment is used when there is no match or when there is an overlap (duplicate numbers in tables with opposite Allow/Deny assignments) of numbers in the 8-Digit Matching Tables.

8-Digit Matching Table Operations

The 8-Digit Matching Tables are used to restrict or allow OCC calls and non OCC calls. To understand the relationship of the 8-Digit Matching Tables with OCC calls, refer to Section 7.4.2 - OCC Assignment/Operation.

When a restricted station user makes a non OCC call, the system monitors the first eight digits dialed and searches the 8-Digit Matching Tables assigned as Allow or Deny. The system searches only the 8-Digit Matching Tables assigned to the Code Restriction Class where the station is assigned. The trunks are assigned to the station on a Trunk Group basis.

If a match is found, the system looks at the 8-Digit Matching Table to Class Assignment for the Allow or Deny Assignment. If the table is assigned as Allow, the call is allowed. If the table is assigned as Deny, the call is denied.

If no match is found or a duplicate match is made with opposite Allow/Deny assignments, the system looks at the Class Allow/Deny Assignment. If the class is assigned as Allow, the call is allowed. If the Class is assigned as Deny, the call is denied. While the station user is dialing on an outside line, the system is searching the assigned tables. If the interdigit time duration of the dialing party exceeds 10 seconds, the system automatically drops the call.

7.4.4 System Speed Dial Override Selection

(Memory Block 1-23)

This Memory Block allows System Speed Dial buffers 60 ~ 99 to override or not override Code Restriction for Code Restriction Classes 1 ~ 6.

7.4.5 Trunk Digit Restriction

(Memory Block 4-23)

This Memory Block specifies, on a per-station basis, the maximum number of digits that can be dialed while on any outside line.

7.4.6 CO/PBX Line Code Restriction Override Selection

(Memory Block 3-12)

This Memory Block specifies whether or not Code Restriction is applied on a per-line basis.

7.4.7 Code Restriction Class Assignment (Day Mode)

(Memory Block 4-21)

This Memory Block specifies, on a per-station basis, the Code Restriction Class to be used when the system is in the Day Mode.

7.4.8 Code Restriction Class Assignment (Night Mode)

(Memory Block 4-22)

This Memory Block specifies, on a per-station basis, the Code Restriction Class used when the system is in the Night Mode.

7.5 Code Restriction Tables

7.5.1 OCC Tables (Default Values)

- OCC Table Assignment (1-60)
- OCC Table to Trunk Group Assignment (1-61)
- 8-Digit Matching Table to OCC Table Assignment (1-62)

	TABLE 01	TABLE 02	TABLE 03	TABLE 04
Memory Block (1-60)	_ _ _ _ _ _ _	_ _ _ _ _ _ _	_ _ _ _ _ _ _	_ _ _ _ _ _ _
Memory Block (1-61)	T.G. 0~2	T.G. 0~2	T.G. 0~2	T.G. 0~2
Memory Block (1-62)				
	TABLE 05	TABLE 06	TABLE 07	TABLE 08
Memory Block (1-60)	_ _ _ _ _ _ _	_ _ _ _ _ _ _	_ _ _ _ _ _ _	_ _ _ _ _ _ _
Memory Block (1-61)	T.G. 0~2	T.G. 0~2	T.G. 0~2	T.G. 0~2
Memory Block (1-62)				
	TABLE 09	TABLE 10	TABLE 11	TABLE 12
Memory Block (1-60)	_ _ _ _ _ _ _	_ _ _ _ _ _ _	_ _ _ _ _ _ _	_ _ _ _ _ _ _
Memory Block (1-61)	T.G. 0~2	T.G. 0~2	T.G. 0~2	T.G. 0~2
Memory Block (1-62)				
	TABLE 13	TABLE 14	TABLE 15	TABLE 16
Memory Block (1-60)	_ _ _ _ _ _ _	_ _ _ _ _ _ _	_ _ _ _ _ _ _	1 0XXX
Memory Block (1-61)	T.G. 0~2	T.G. 0~2	T.G. 0~2	T.G. 0~2
Memory Block (1-62)				

Note: X = 0~9, *, #
 P = 0, 1
 N = 2~9

7.5.2 8-Digit Matching Tables (Default Values)

- 8-Digit Matching Table to Trunk Group Assignment (1-59)
- 8-Digit Matching Table Assignment (1-56)

Memory Block (1-59)
Memory Block (1-56)

	TABLE 01	TABLE 02	TABLE 03	TABLE 04
	T.G. 0~2		T.G. 0~2	
1	9 1 1			
2				
3				
4				
5				
6				
7				
8				

Memory Block (1-59)
Memory Block (1-56)

	TABLE 05	TABLE 06	TABLE 07	TABLE 08
	T.G. 0~2		T.G. 0~2	
1				
2				
3				
4				
5				
6				
7				
8				

Note: X = 0~9, *, #
P = 0, 1
N = 2~9

(Continued on next page.)

Memory Block (1-59)
Memory Block (1-56)

TABLE 09

T.G. 0~2	
1	
2	
3	
4	
5	
6	
7	
8	

TABLE 10

T.G. 0~2	
1	
2	
3	
4	
5	
6	
7	
8	

TABLE 11

T.G. 0~2	
1	
2	
3	
4	
5	
6	
7	
8	

TABLE 12

T.G. 0~2	
1	0
2	
3	
4	
5	
6	
7	
8	

Memory Block (1-59)
Memory Block (1-56)

TABLE 13

T.G. 0~2	
1	9 7 6
2	
3	
4	
5	
6	
7	
8	

TABLE 14

T.G. 0~2	
1	1 8 0 0
2	
3	
4	
5	
6	
7	
8	

TABLE 15

T.G. 0~2	
1	1 X
2	
3	
4	
5	
6	
7	
8	

TABLE 16

T.G. 0~2	
1	X
2	
3	
4	
5	
6	
7	
8	

Note: X = 0~9, *, #
P = 0, 1
N = 2~9

- Class Allow/Deny Assignment (1-57)
- 8-Digit Matching Table to Class Assignment (1-58)

8-Digit Matching Table To Class Assignment (M.B. 1-58)

	01	02	03	04	05	06	07	08	09	10	11	12	13	14	15	16	Class Allow/Deny Assignment Memory Block (1-57)
Class 1	1	N/A	N/A	N/A	N/A	N/A	N/A	N/A	N/A	N/A	N/A	0	N/A	N/A	0	2	Allow
Class 2	1	N/A	N/A	N/A	N/A	N/A	N/A	N/A	N/A	N/A	N/A	0	N/A	1	0	2	Allow
Class 3	1	N/A	N/A	N/A	N/A	N/A	N/A	N/A	N/A	N/A	N/A	0	0	1	0	2	Allow
Class 4	1	N/A	N/A	N/A	N/A	N/A	N/A	N/A	N/A	N/A	N/A	N/A	N/A	1	0	2	Allow
Class 5	1	N/A	N/A	N/A	N/A	N/A	N/A	N/A	N/A	N/A	N/A	N/A	N/A	N/A	N/A	N/A	Deny
Class 6	1	N/A	N/A	N/A	N/A	N/A	N/A	N/A	N/A	N/A	N/A	N/A	N/A	N/A	N/A	N/A	Deny

Note 1: 0 = Deny
 1 = Allow
 2 = Deny (OCC Calls Only)
 3 = Allow (OCC Calls Only)
 N/A = Not Applicable

Note 2: A maximum of six, 8-Digit Matching Tables can be assigned to each Class (software version 2.0 or lower).

All sixteen 8-Digit Matching Tables can be assigned to each Class (software version 2.72 or higher).

7.6 Code Restriction Algorithm

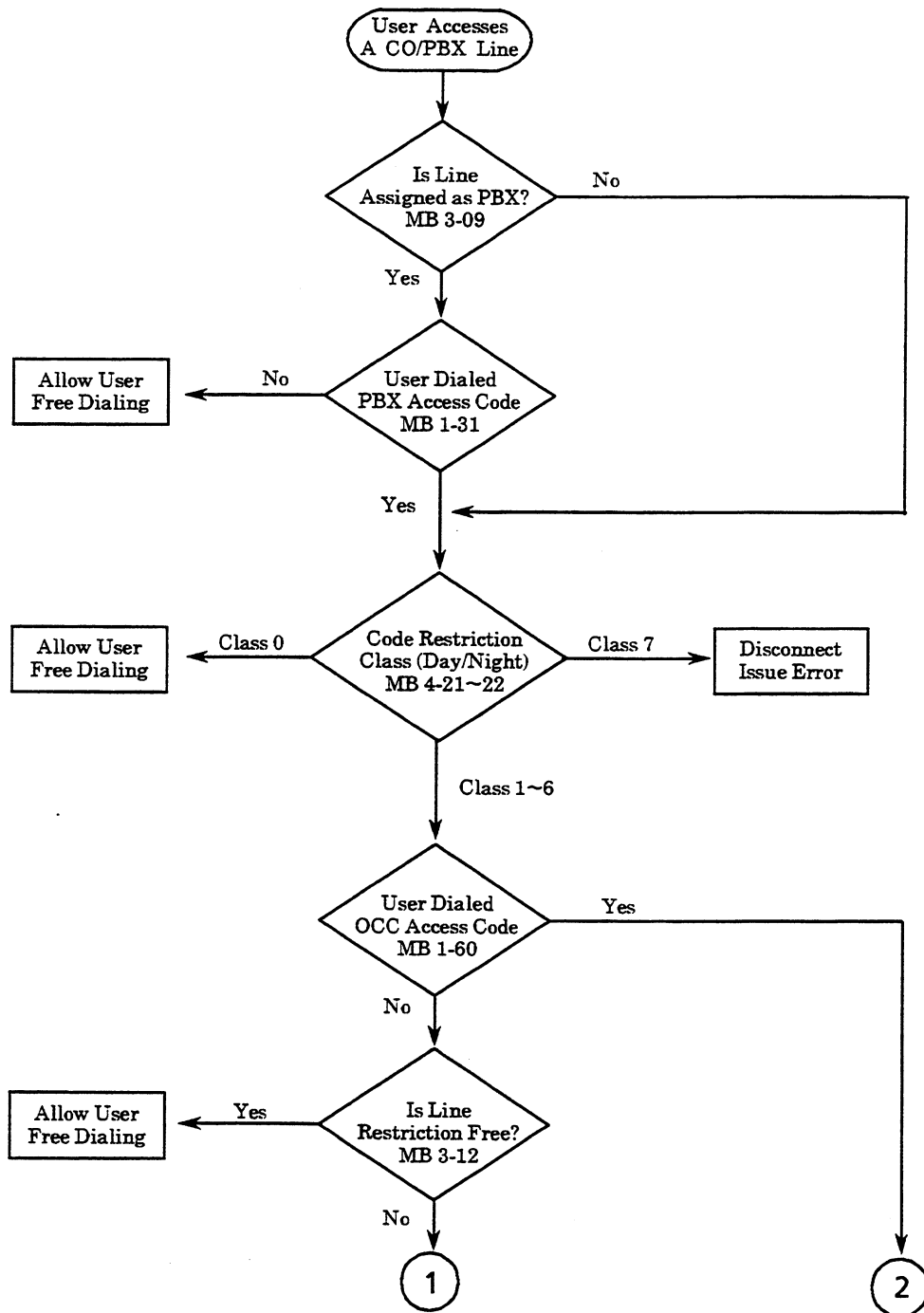

(Continued on next page.)

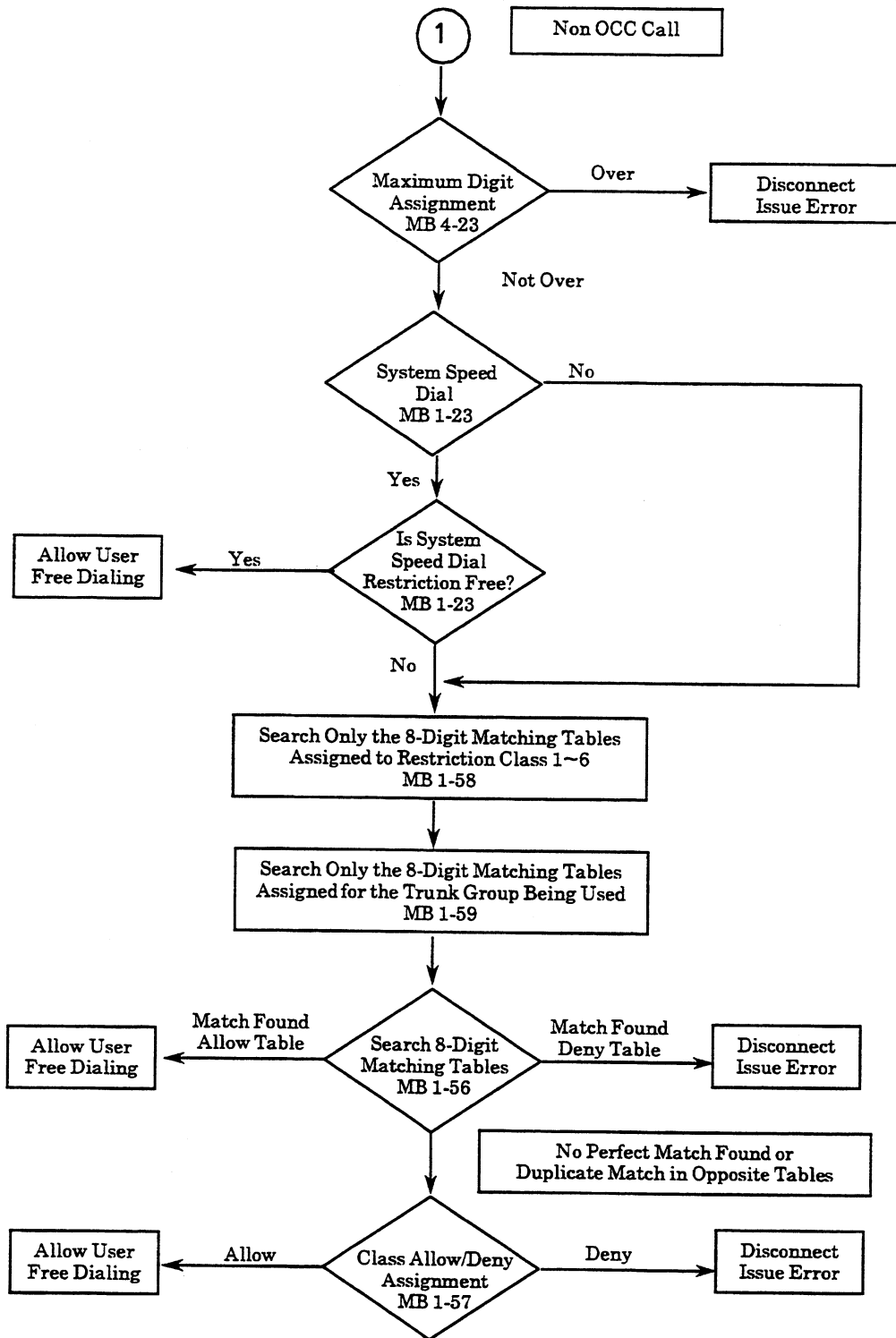

(Continued on next page.)

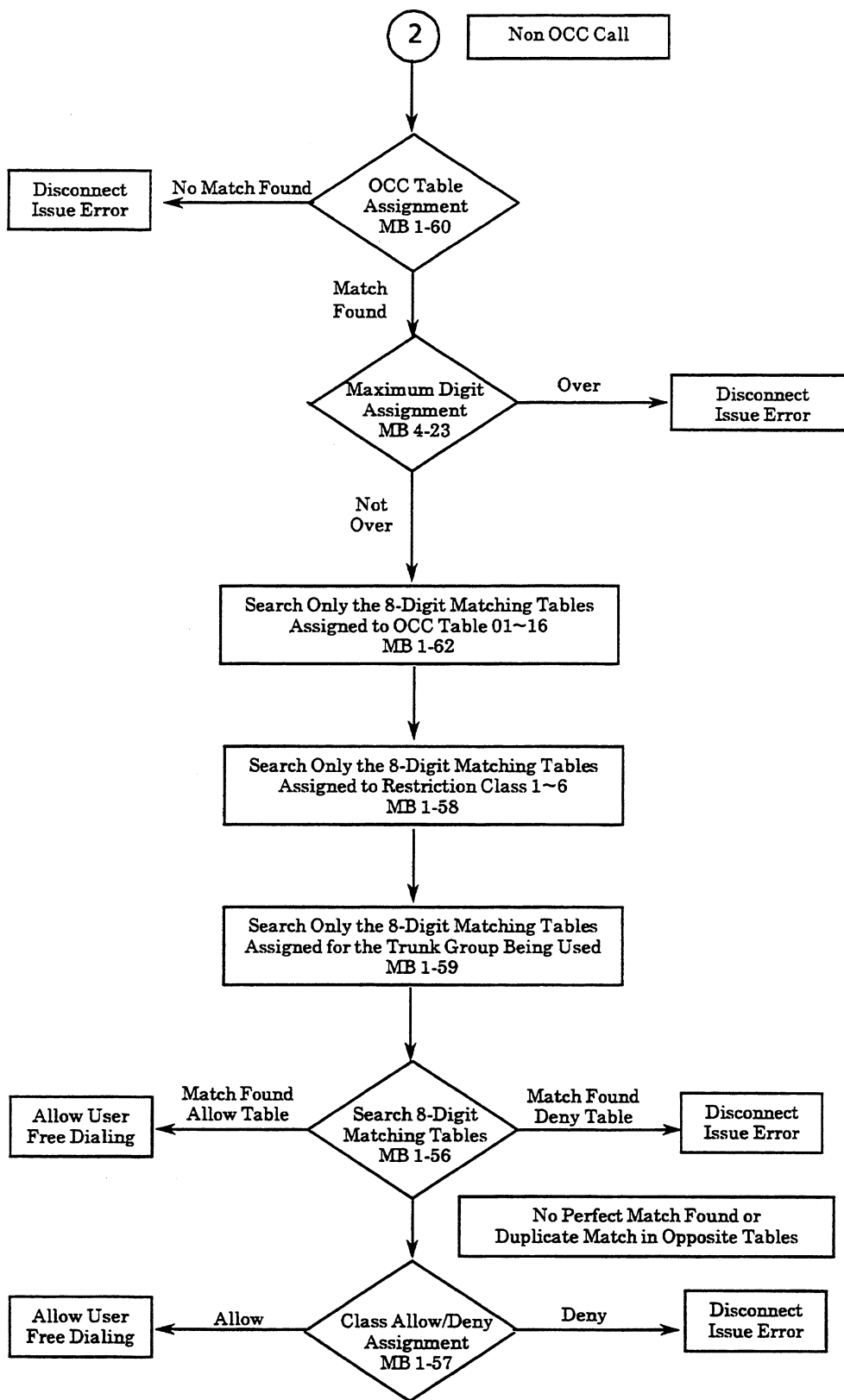

THIS PAGE INTENTIONALLY LEFT BLANK

SECTION 8 DISPLAY ABBREVIATIONS

The abbreviations as they appear in the display of the Multiline Terminal are listed on the following pages. The definition is listed to the right of each abbreviation.

ADD/DEL	: addition/deletion	EXT MOH	: external music on hold
ALM	: alarm	FLSH	: flash
ANS	: answer	FLSH END	: flash end
ARDT	: automatic release detect timer	FLSH ST	: flash start
ASSGN	: assignment	FWD	: forward
ATO	: automatic	FWD NOANS	: forward no answer
ATT	: attendant	FWDG	: forwarding
AUTO DIS	: automatic disconnect	GP	: group
BGM	: background music	H	: high
BNCE	: bounce	HDFREE	: handsfree
CHM	: chime	HFU	: handsfree unit
CL	: class	HOFREETRF	: hold free transfer
CLR	: clear	HOLD RECL	: hold recall
CLS	: class	HR	: hour
CONN	: connection	IN	: incoming
DIG	: digit	INTER	: interdigit
DIS	: disconnect	L	: low
DISP	: display	LCD	: liquid crystal display
DLY	: delay signal time	LN	: line
DP	: dial pulse	LNR/SPD	: last number/speed dial
DP INTER	: dial pulse interdigit	m	: minute
DPH	: doorphone	M	: medium
DPH DSP	: doorphone display	MAN	: manual
DPH PRF	: doorphone preference	MF	: dual-tone multifrequency (DTMF)
DSP TM	: display time	MOH	: music on hold
DSS	: direct station selection	ms	: millisecond
DUR	: duration	MSTER	: master
DY	: day mode	NANP	: North American Numbering Plan
DYTM	: daytime	NBR	: number
ESP	: external speaker	NOANS	: no answer
EXT RG	: external ring	NON	: no assignment
EXHDRECL	: exclusive hold recall	NONREST	: nonrestricted
EXT	: external	NT	: night mode

(Continued on next page.)

NT CHM	: night chime	SEL	: selection
NTTM	: night time	SLT	: single line telephone
OFTM	: off time	SP	: speaker
OUT	: outgoing	SPD	: speed dial
PAG	: paging	SPDOVR	: speed dial override
PBR	: push button receiver	SYS	: system
PBR RLS	: push button release	TEL	: telephone
PBX	: public branch exchange	TM	: time
PBX AC	: PBX access code	TR TY	: trunk type
PRF	: preference	TRF	: transfer
PRNT	: print	TRK	: trunk
QUE	: queue	TRK GP	: trunk group
RCV	: receiving volume	TRNS	: transfer
RECL	: recall	TYP	: type
REST	: restriction	VCO	: voice over
RG	: ring	VM	: voice mail
RINGTONE	: ringing tone	VRS	: voice recording service
RLS	: release	WK	: weekend
s	: second	YS	: yes

CHAPTER 3

SYSTEM MAINTENANCE

CHAPTER 3
SYSTEM MAINTENANCE
TABLE OF CONTENTS

SECTION 1	INTRODUCTION	3-1
SECTION 2	OPERATIONAL CURRENT AND VOLTAGE CHECKS	3-1
2.1	Power Requirements	3-1
2.2	Equipment Needed.	3-1
SECTION 3	OPERATIONAL TEST PROCEDURES.....	3-1
3.1	General.	3-1
3.2	Before Installation	3-1
3.3	System Initialization	3-2
3.4	After Initialization	3-2
SECTION 4	TROUBLESHOOTING FLOWCHARTS.....	3-3
4.1	Problem Solving	3-3

LIST OF TABLES

3-1	Voltage Measurement.	3-2
3-2	Index Table of Flowcharts	3-4

LIST OF FLOWCHARTS

A1	No Internal Dial Tone to Any Multiline Terminal or SLT.....	3-5
A2	No LED or Display Indications on Any Multiline Terminal	3-6
B1	No CO/PBX Ring or Intermittent CO/PBX Ring Problems	3-7
B2	Call Dropping	3-8
B3	No Outside Dial Tone Access	3-9
B4	CO/PBX Dialing Problem (Cannot Dial Out on CO)	3-10
C1	Multiline Terminal Function Problems	3-11
C2	Multiline Terminal Ringing Problems	3-12
C3	Multiline Terminal Dial Tone Access Problems	3-13
D1	No Dial Tone Access on SLT.....	3-14
D2	Ringing Problem on SLT.....	3-15

D3	No Dial Access to Features on SLT.....	3-16
E1	Low Volume Problems.....	3-17
F1	External Paging Problem.....	3-18
G1	SMDR Output Problems (No Call Accounting System).....	3-19

CHAPTER 3

SYSTEM MAINTENANCE

SECTION 1 INTRODUCTION

Use this chapter as a guide for diagnosis and troubleshooting problems during and after system installation. The troubleshooting flowcharts and general test procedures help to identify the cause of a problem by defining the problem area.

SECTION 2 OPERATIONAL CURRENT AND VOLTAGE CHECKS

2.1 Power Requirements

The effectiveness of this portion of the maintenance section depends on the technician's ability to answer correctly all questions in the flowcharts as accurately as possible. Due to external factors, it is important that no answer be assumed.

For example, it cannot be assumed that a new power supply which has replaced a faulty power supply is working properly. The output of the power supply must be tested with a volt meter. This can be done in the KSU by measuring +5V and +28V from the CN1 plug on the PSU. Before a technician can attempt any troubleshooting, the correct tools should be available.

2.2 Equipment Needed

- Digital or Analog Multimeter
- Lineman's test set:
 1. Termination and Monitor Modes
 2. DTMF and Dial Pulse dialing
- Hand tools:
 1. Set of screwdrivers (common and Phillips head blades)
 2. Set of pliers, long nose and diagonals
 3. Punch down tool

SECTION 3 OPERATIONAL TEST PROCEDURES

3.1 General

When the system is first powered up, it runs through an initialization process. During this process, the CPU inside the basic KSU scans each of the KTUs to determine the hardware configuration used. This information is stored in the Resident System Program memory with the system default values. This section provides test procedures to be used before, during, and after the initialization process.

3.2 Before Installation

It is important that the following steps be taken by the technician installing the system:

1. Cable Connections

All wiring for power supplies and flat cable connectors should be checked for solid connections. Refer to Chapter 1 - Hardware Specifications and Installation of this manual for connection instructions.

2. AC/DC Power

Check all power with an AC/DC multimeter. (Refer to Table 3-1 - Voltage Measurement).

Table 3-1 Voltage Measurement

Voltages	Tolerance	Measuring Points
<u>PSF-C-10 PSU</u> + 5V + 28V	+ 5 ± 0.25V + 5 ± 0.25V	CN1 Pin 4 GND Pin 3 +5V Pin 1 + 28V
<u>AC Voltage (117 Vac)</u> Line to Neutral Line to Conduit Ground Neutral to Conduit Ground	117 ± 15% Vac 117 ± 15% Vac .05 V ac (max.)	AC TERMINAL STRIP Line L to N Line L to G N to G
Ring Generator (SLT)	65~ 120 V ac @ 20 Hz (Refer to Note below.)	Across TIP & RING of ringing SLT
<u>CO Line</u> Off-hook line current	25 to 50 mA	In series with TIP side of CO line at MDF

Note: Measurement of ring voltage may be lower if the meter is designed for measuring 60 Hz signals only.

3. Initialization Check

To determine if the system is initializing correctly, removing all optional and expansion KTUs from the system is recommended. After initialization, all terminals in the main board and ESI-C(8)-11 should be able to call each other internally. (These stations, by default, are assigned station numbers 10~25.)

3.3 System Initialization

After the three steps in Section 3.2 are completed and verified, the entire system should be initialized.

With the power off, all the interface and option cards can be installed in the KSU as indicated on the Job Specifications Worksheet. It is important to ensure that the lithium battery is removed from the ESF-C-10 KSU. At this point the technician can power up the system. This performs a First Initialization of the system. After the initialization process, each station display shows default time and date indication.

Example: 12:00 PM SUN 01.

3.4 After Initialization

Before any programming is attempted, the lithium battery should be inserted into the right position on the main board of the ESF-C-10 KSU. This prevents all completed programming from being lost if the system loses power.

After all previous steps are performed and any problems corrected, the System Programming can be completed. Using the Job Specifications Worksheets from the

Electra Professional Level I Job Specifications Manual, Stock No. 722004 (supplied with the ESF-C-10 KSU) helps to simplify the programming process.

CAUTION

Ensure the lithium battery is on the ESF-C-10 KSU.

Performing a System Initialization a second time causes all programming memory to be lost.

This completes the installation. The technician should check the operation of each Multiline Terminal to ensure the system is working properly.

SECTION 4 TROUBLESHOOTING FLOWCHARTS

4.1 Problem Solving

To find the cause of a problem, first consider all the symptoms carefully. It is imperative the problem be defined as accurately as possible so the most efficient steps to a solution can be taken. The troubleshooting flow charts in this section help define problems and direct the technician through the troubleshooting steps. (Refer to Table 3-2 - Index Table of Flowcharts.)

- **System Down**

Although this term can be used to describe many conditions, it is used in this section only to describe one of the following situations:

1. No access to internal dial tone on any Multiline Terminal or Single Line Telephone installed.
2. No LED indications or no display indications on any Multiline Terminal installed.

- **Partial Operation**

This term refers to any situation that cannot be completely described under the conditions of a **SYSTEM DOWN**. (Refer to the Table 3-2 - Index Table of Flowcharts listing these conditions.)

- **Reset Definition**

In the troubleshooting flowcharts, the technician is at times directed to reset the station and/or KTU.

1. Terminal Reset is accomplished by unplugging the station line cord from the station and then plugging it back in.
2. **Do not install any KTUs with power ON.**

COI-C(2)-10 KTU

COI-C(2A)-10 KTU

ESI-C(8)-11 KTU

PBR-C(4)-11 KTU

VRS-C(1)-11 KTU

SMDR-C-10- KTU

FAX-C(1)-11 KTU

Table 3-2 Index Table of Flowcharts

Condition	Flowchart Number	Page Number
A. System Down		
1. No Internal Dial Tone to Any Multiline Terminal or SLT	A1	3-5
2. No LED or Display Indications on Any Multiline Terminal	A2	3-6
B. Partial Operations		
1. Central Office Line Problems:		
A. No CO/PBX Ring or Intermittent CO/PBX Ring Problems	B1	3-7
B. Call Dropping	B2	3-8
C. No Outside Dial Tone Access	B3	3-9
D. CO/PBX Dialing Problem (Cannot Dial Out on CO)	B4	3-10
2. Multiline Terminal Problems:		
A. Multiline Terminal Function Problems	C1	3-11
B. Multiline Terminal Ringing Problems	C2	3-12
C. Multiline Terminal Dial Tone Access Problems	C3	3-13
3. Single Line Telephone Problems:		
A. No Dial Tone Access on SLT	D1	3-14
B. Ringing Problem on SLT	D2	3-15
C. No Dial Access to Features on SLT	D3	3-16
4. Low Volume Problems	E1	3-17
5. External Paging Problem	F1	3-18
6. SMDR Output Problems (No Call Accounting System)	G1	3-19

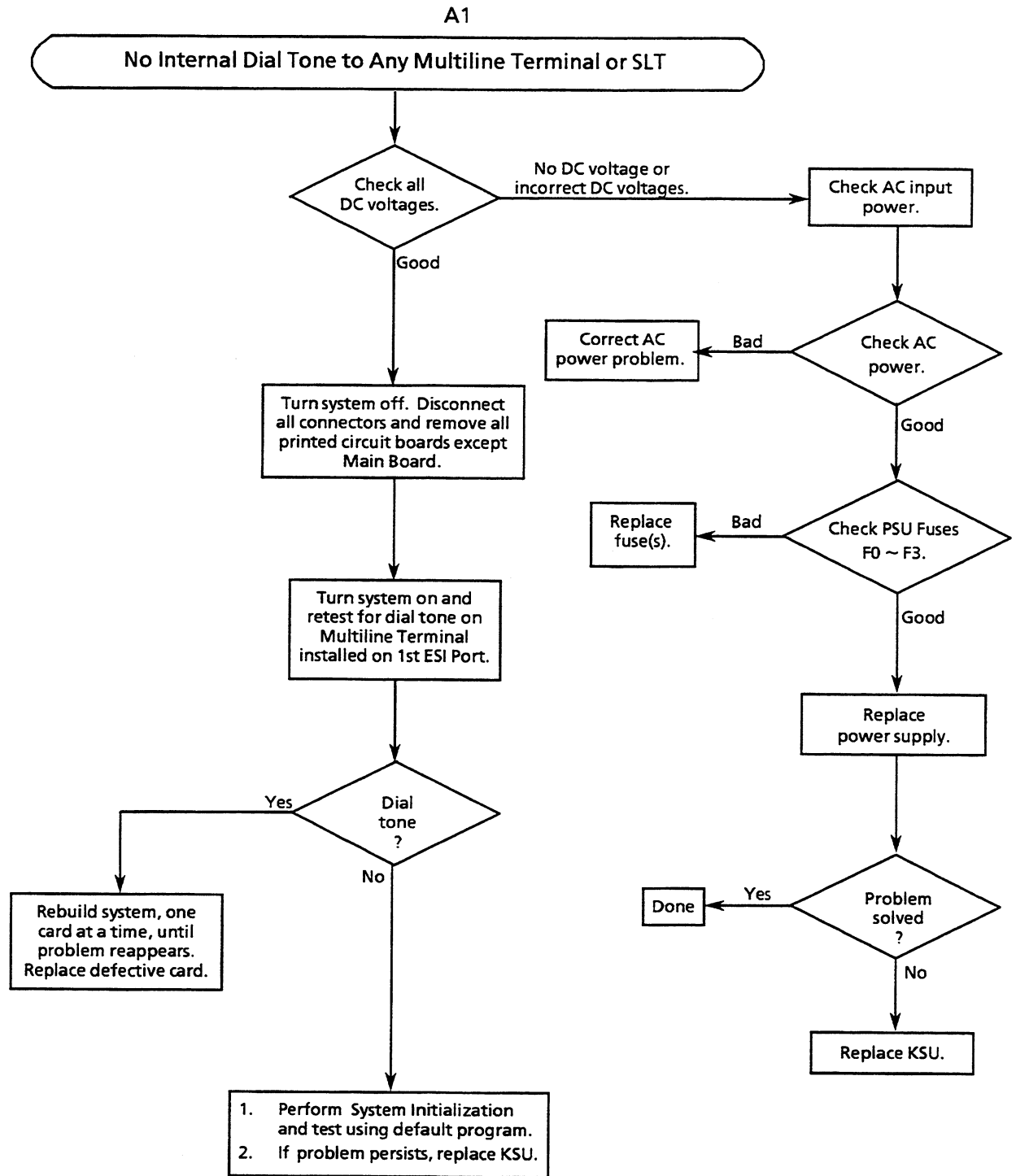

A2

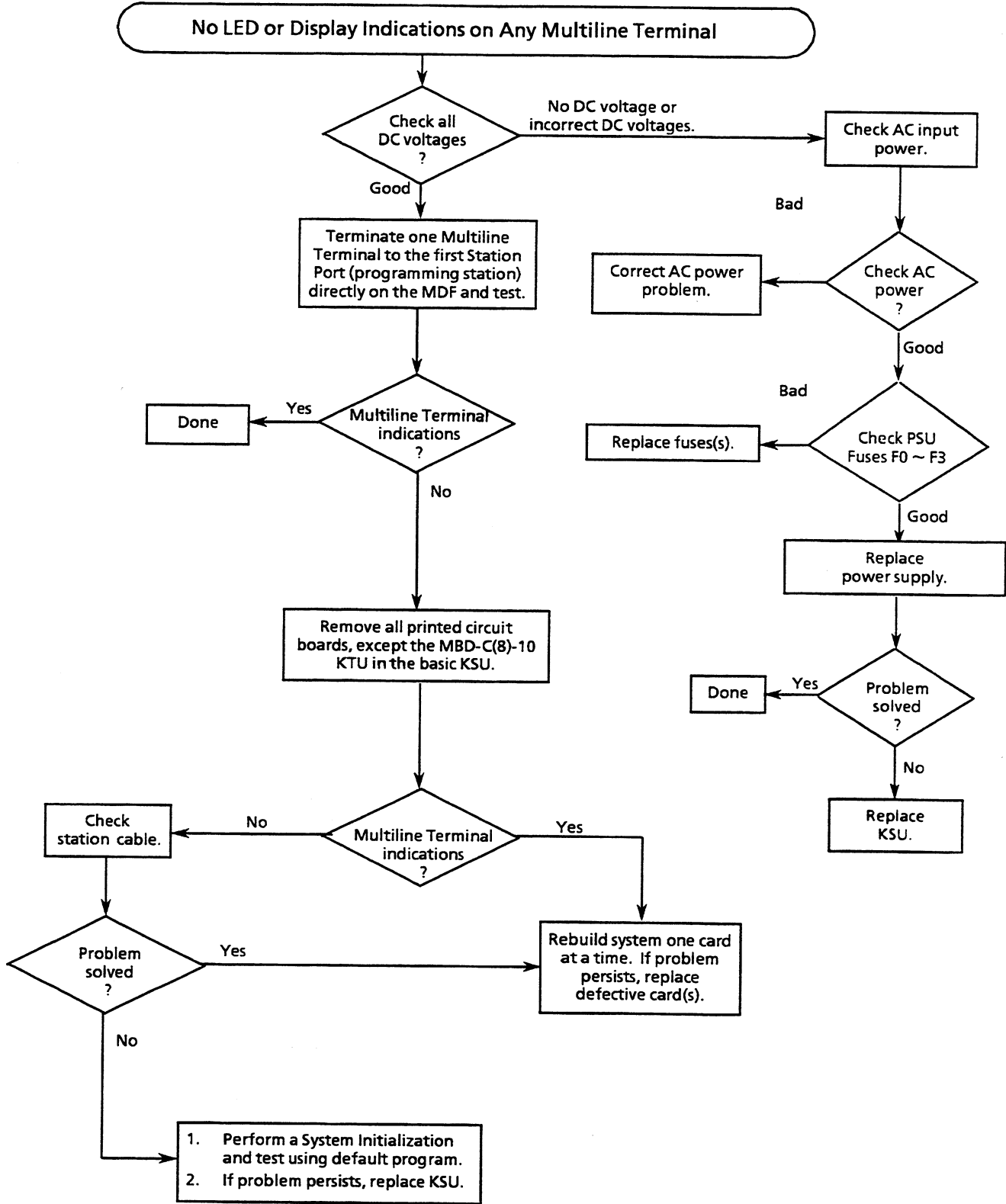

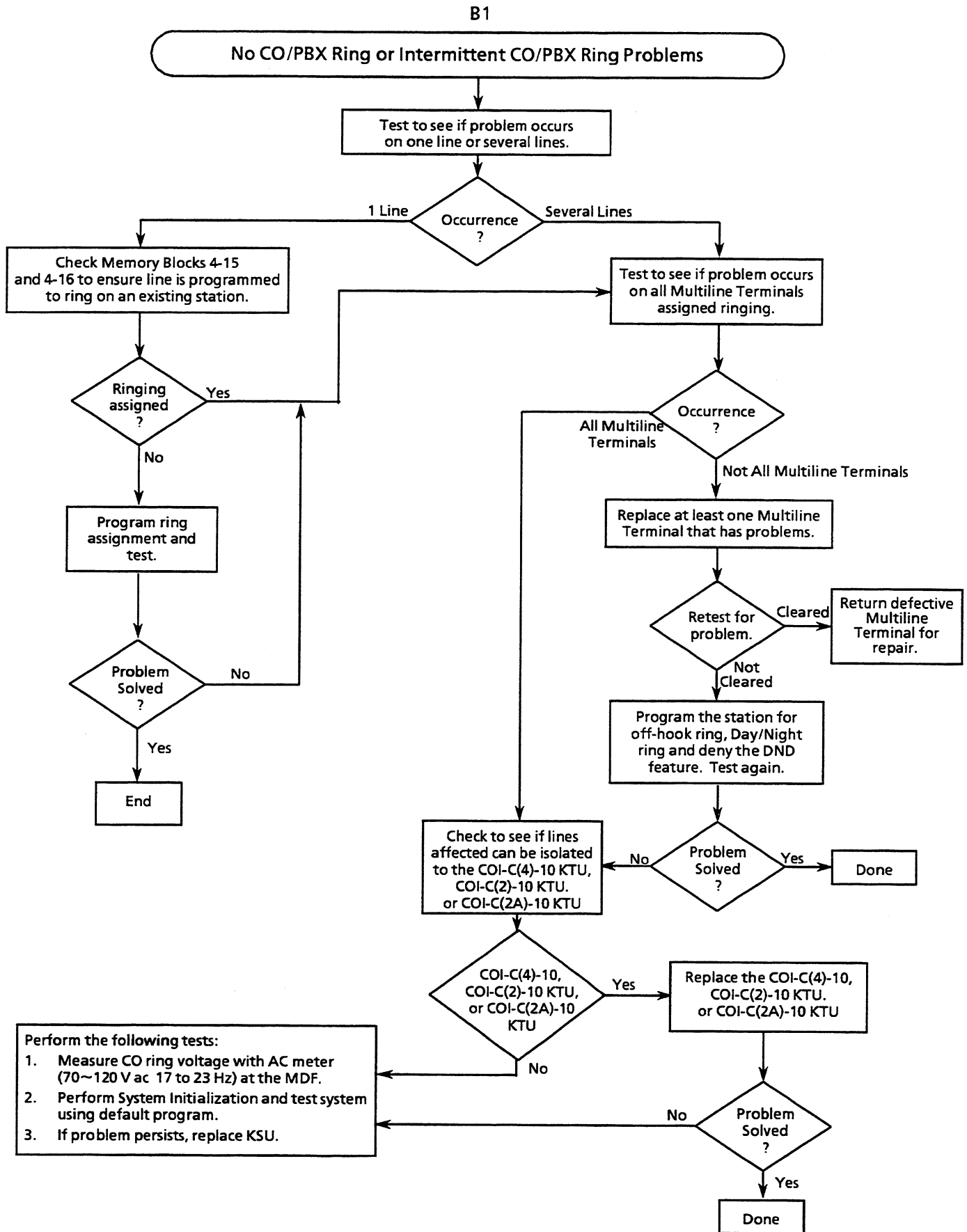

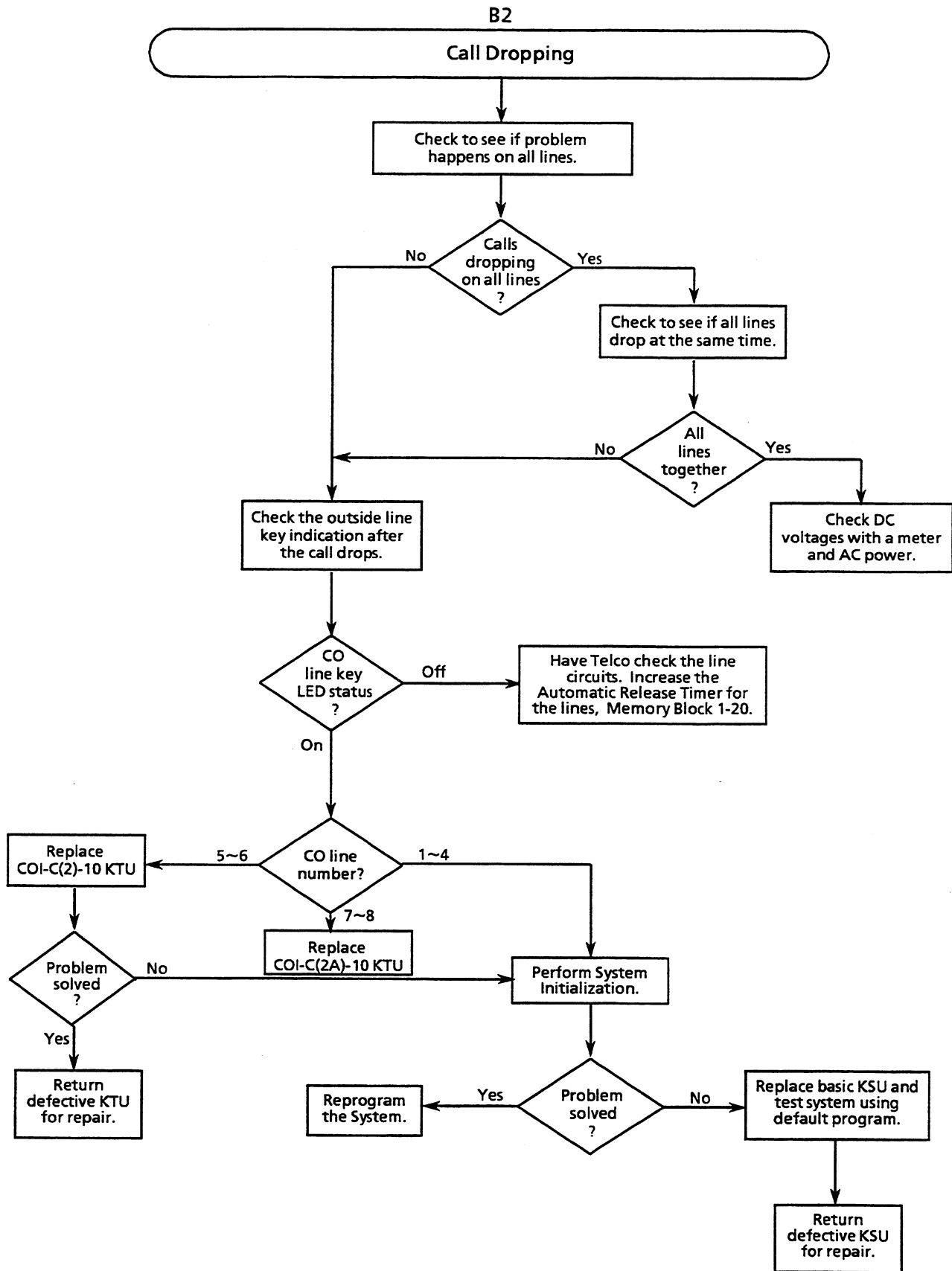

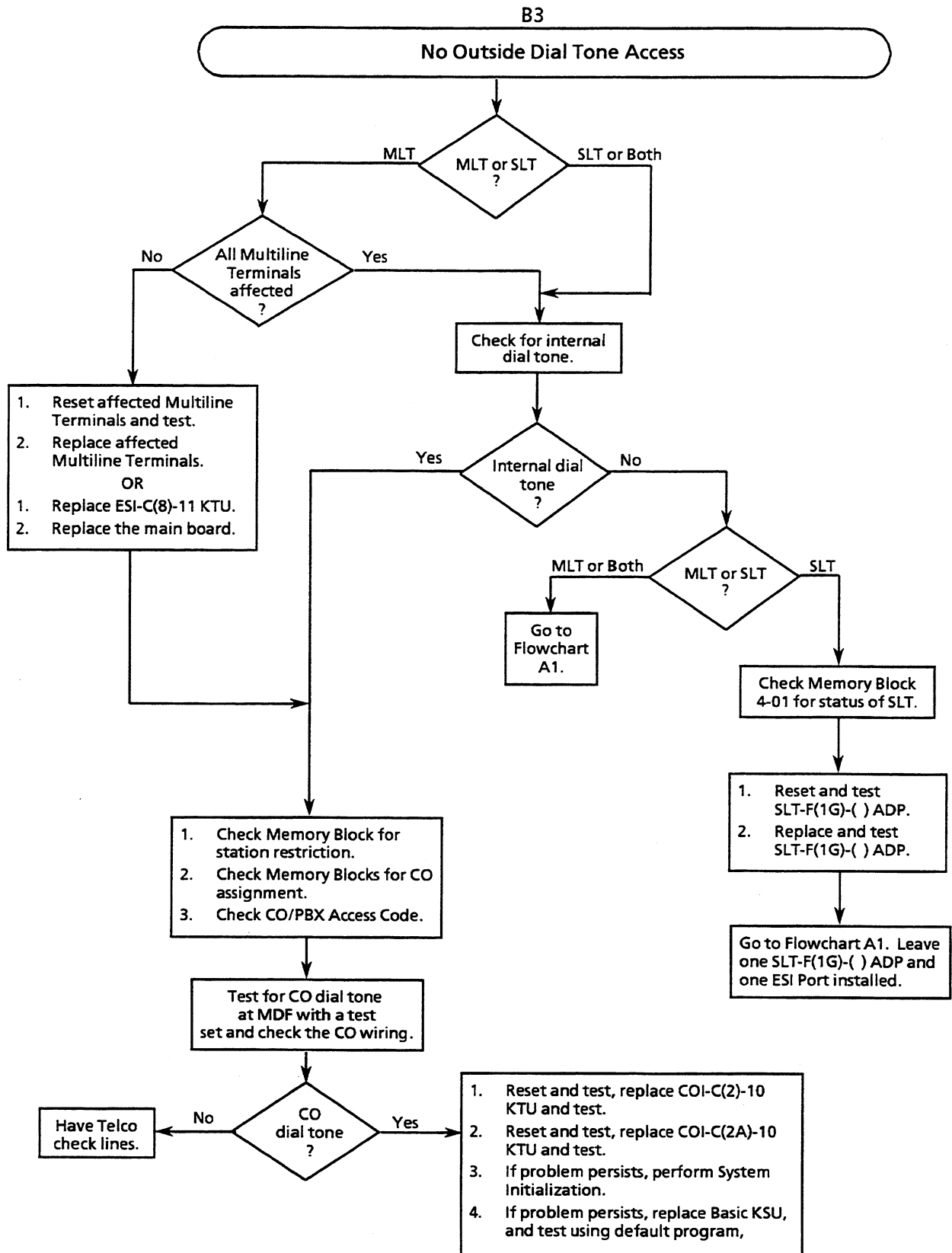

B4

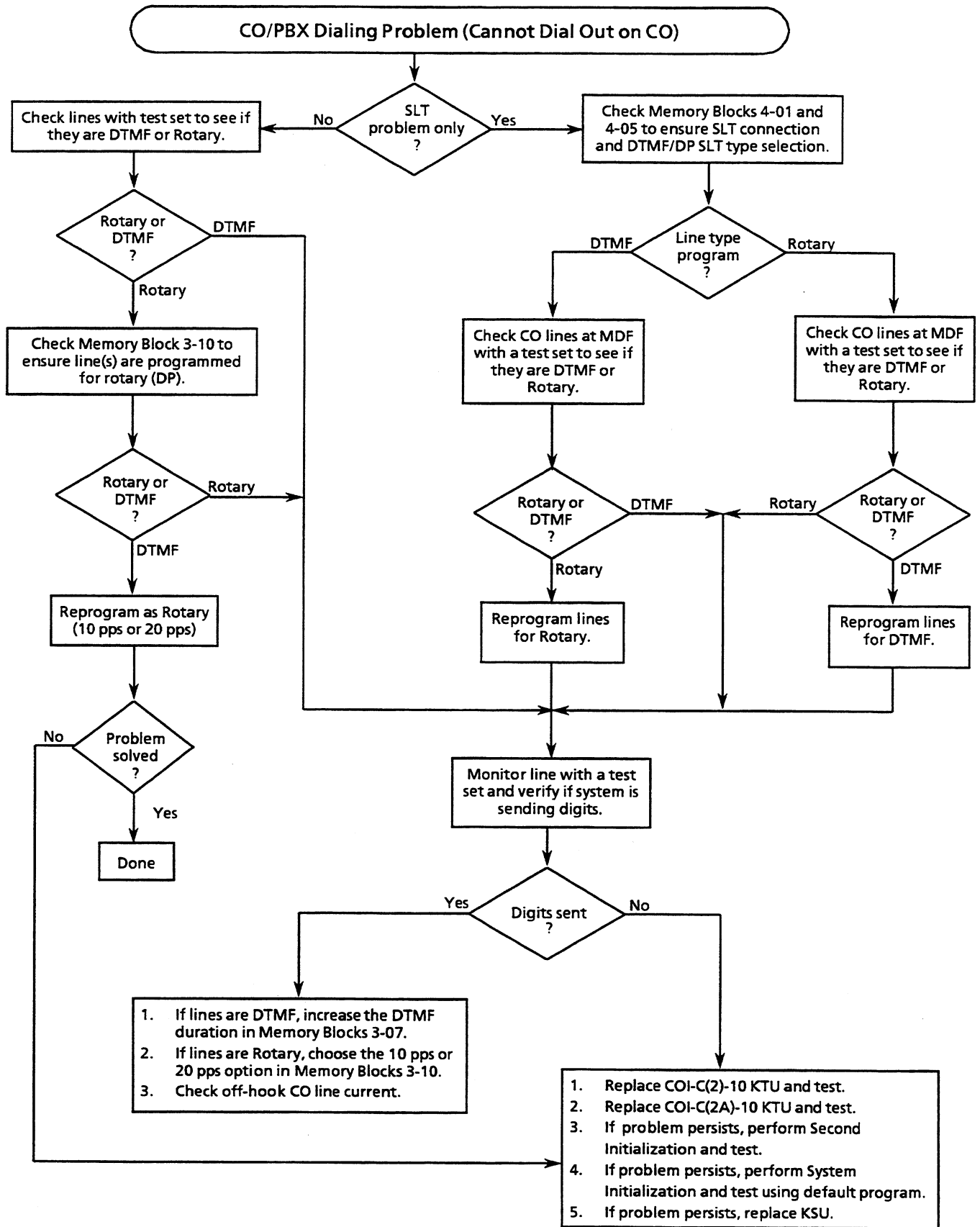

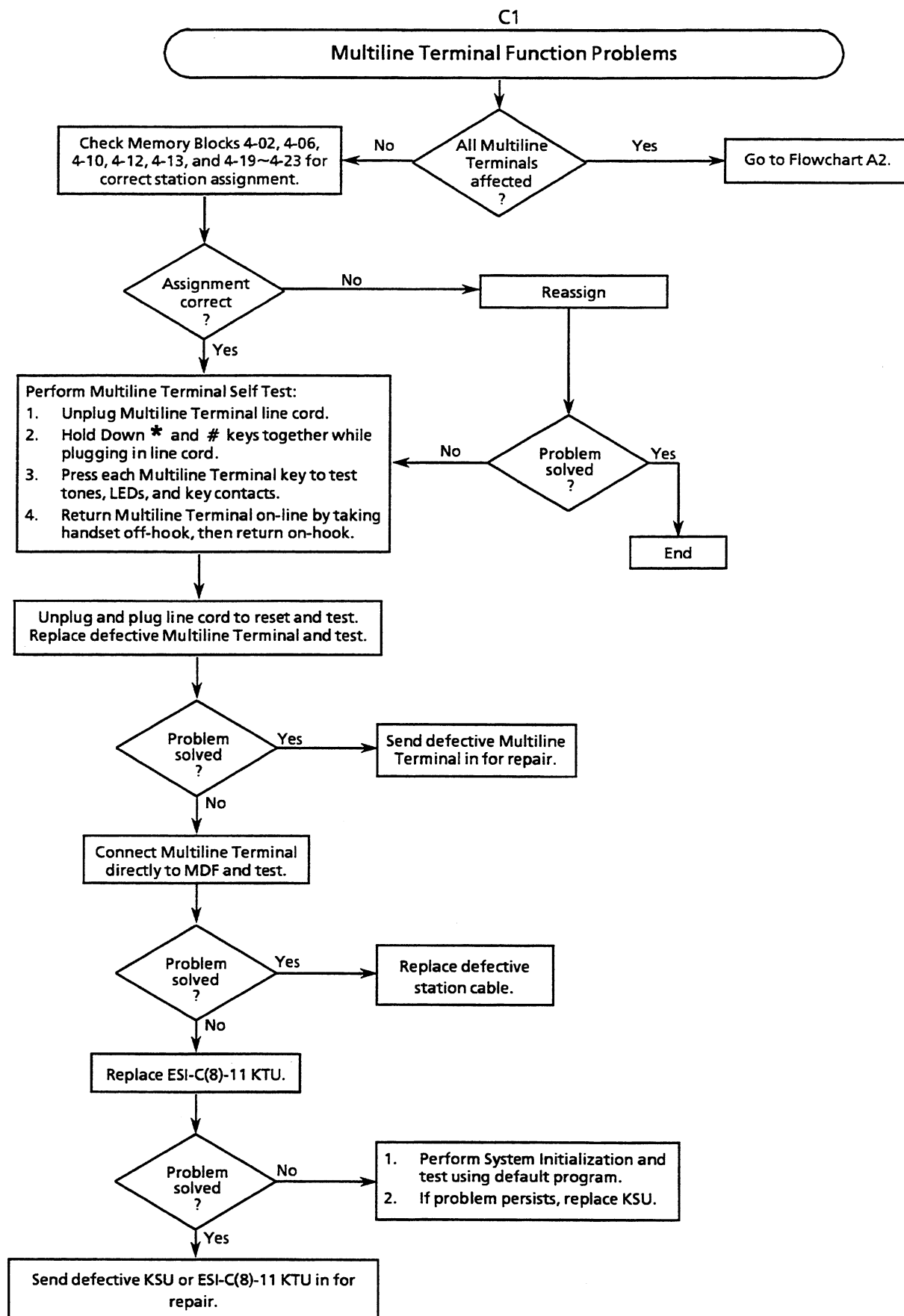

C2

Multiline Terminal Ringing Problems

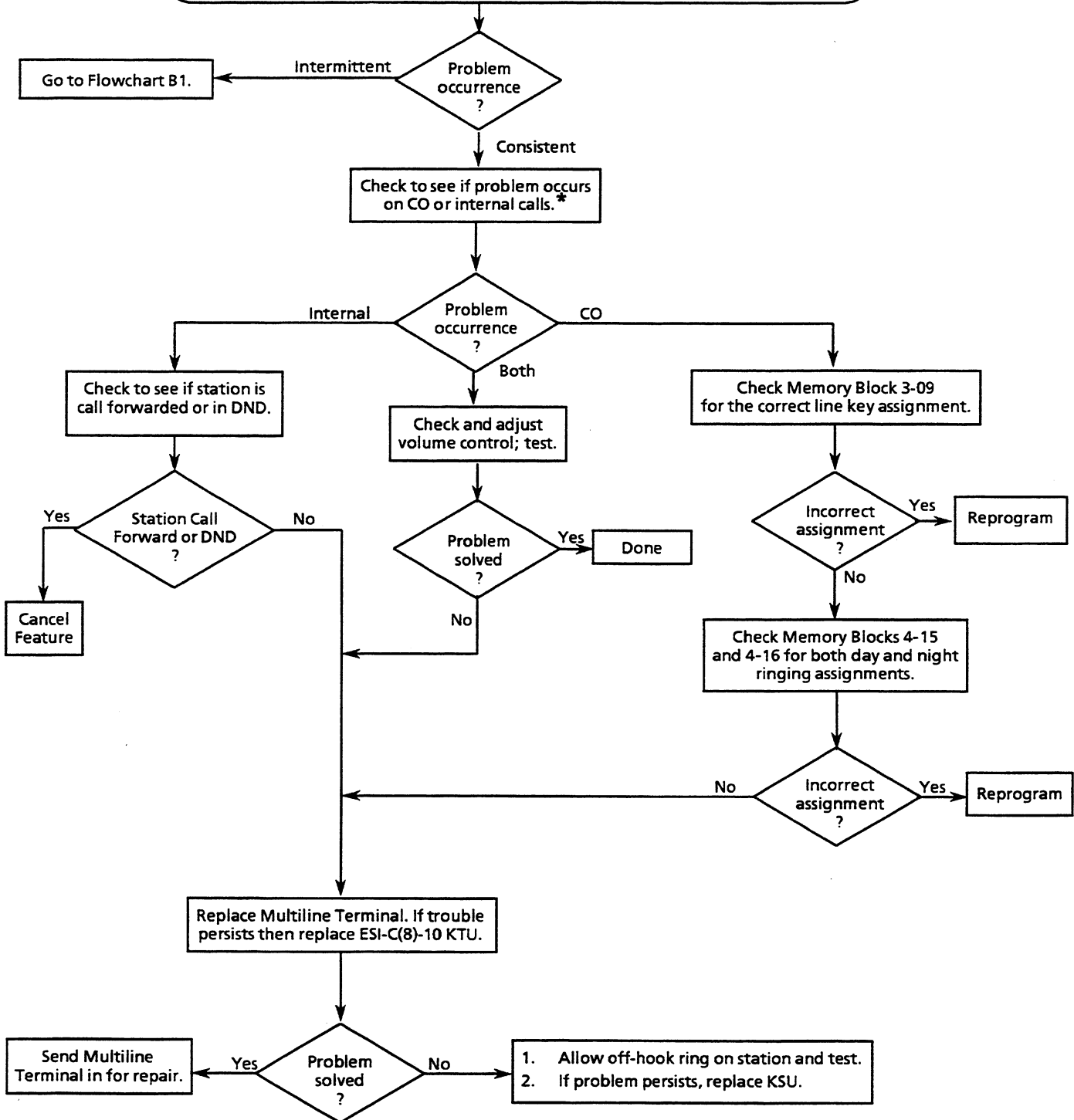

*Note: Internal calls include station-to-station as well as transferred calls.

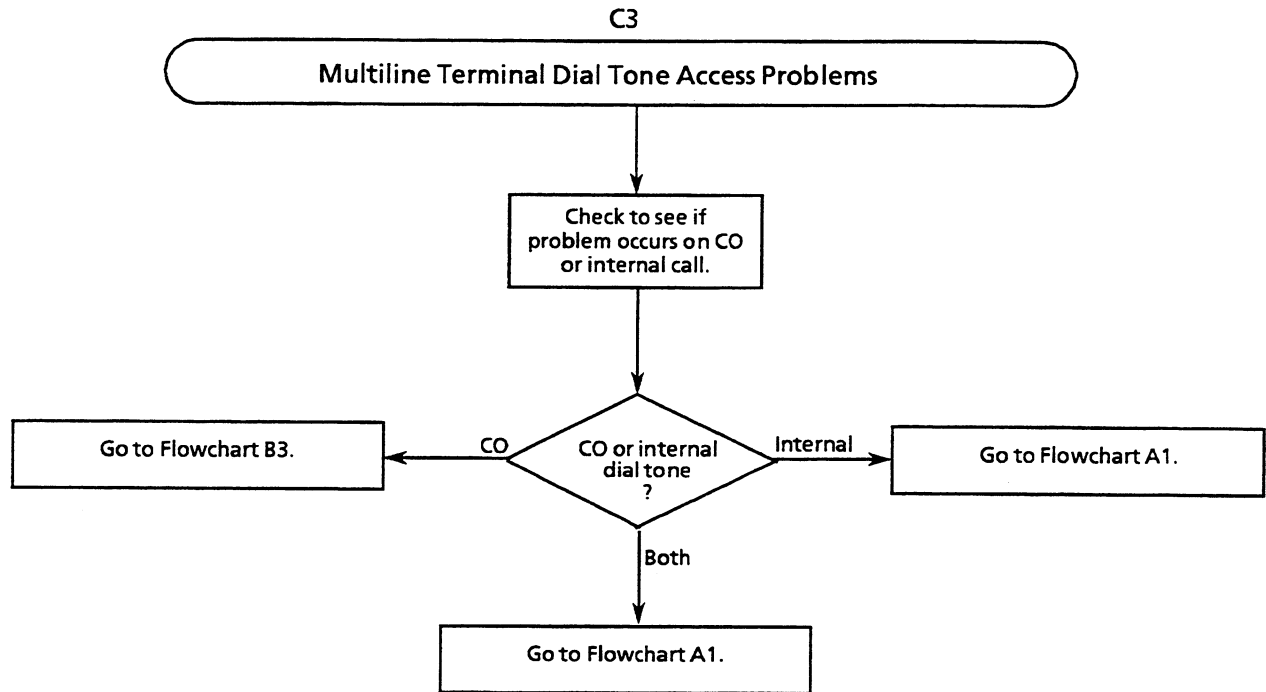

D1

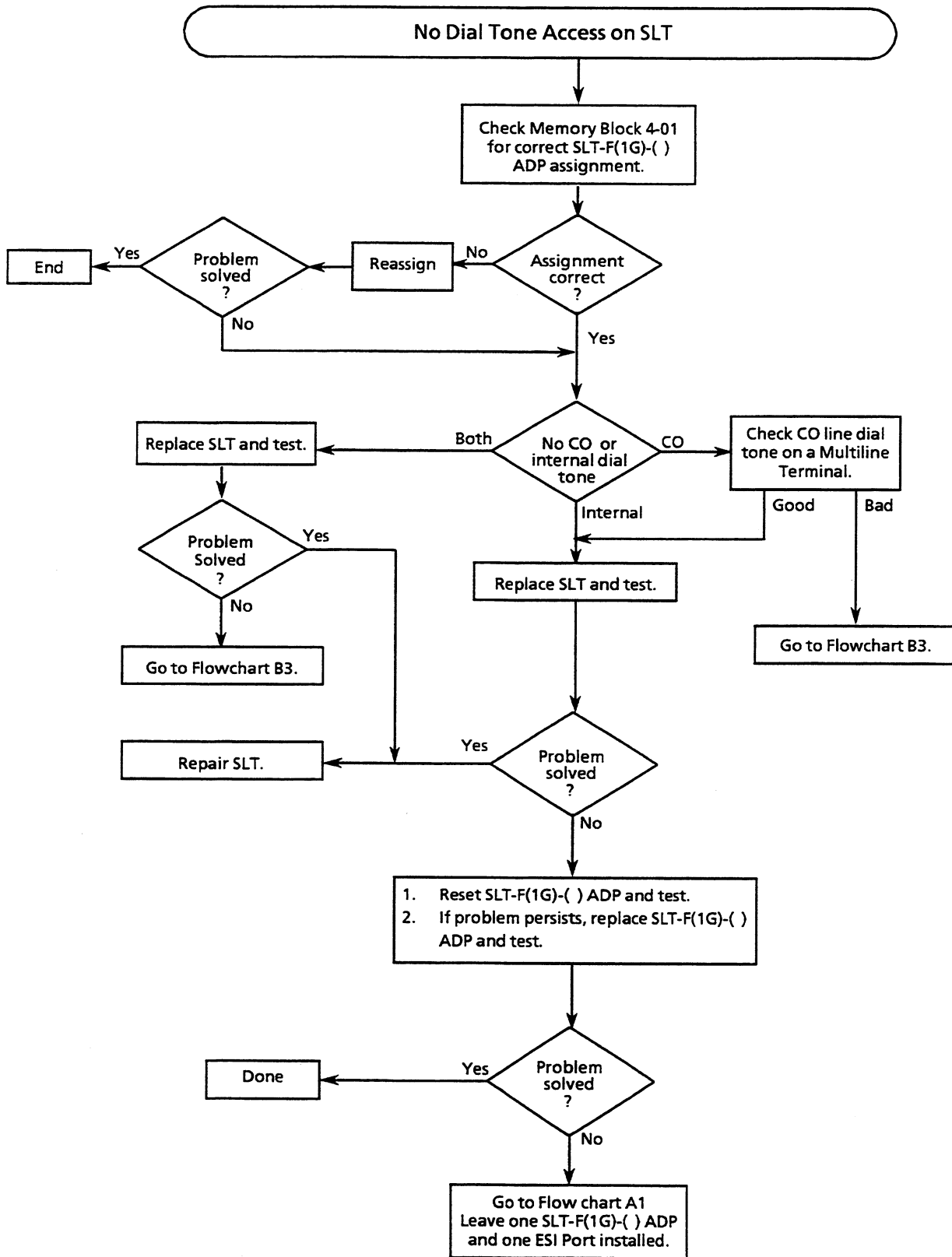

D2

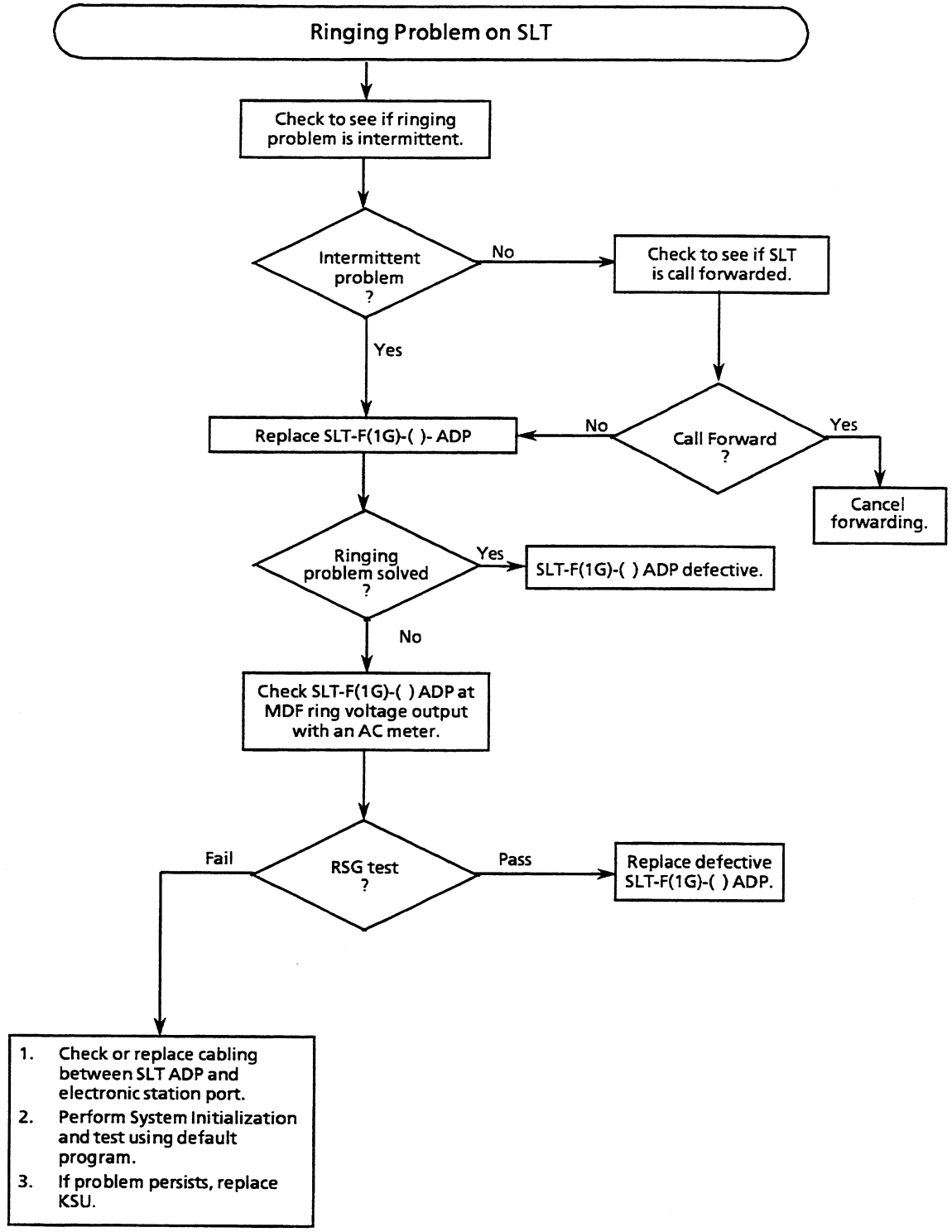

D3

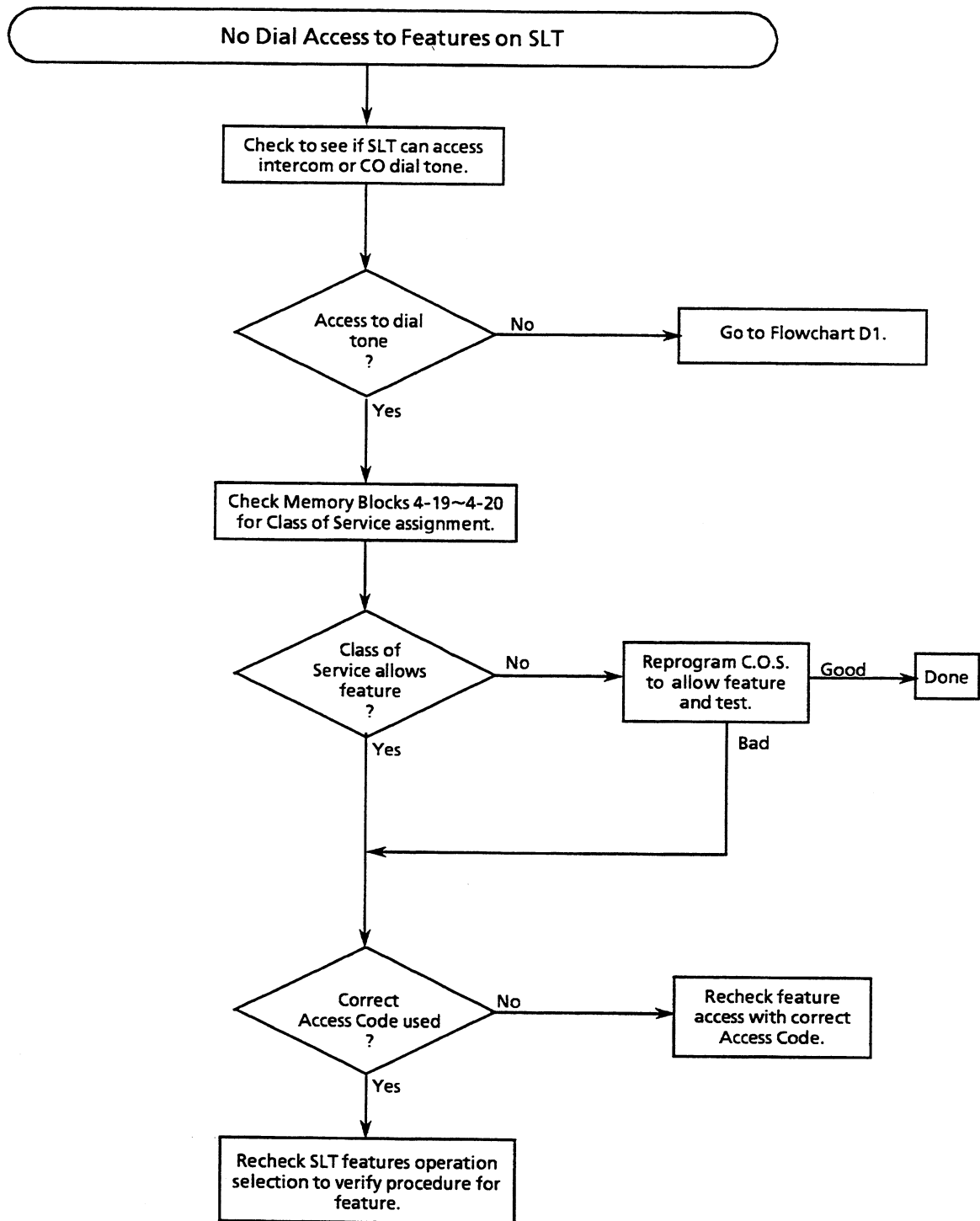

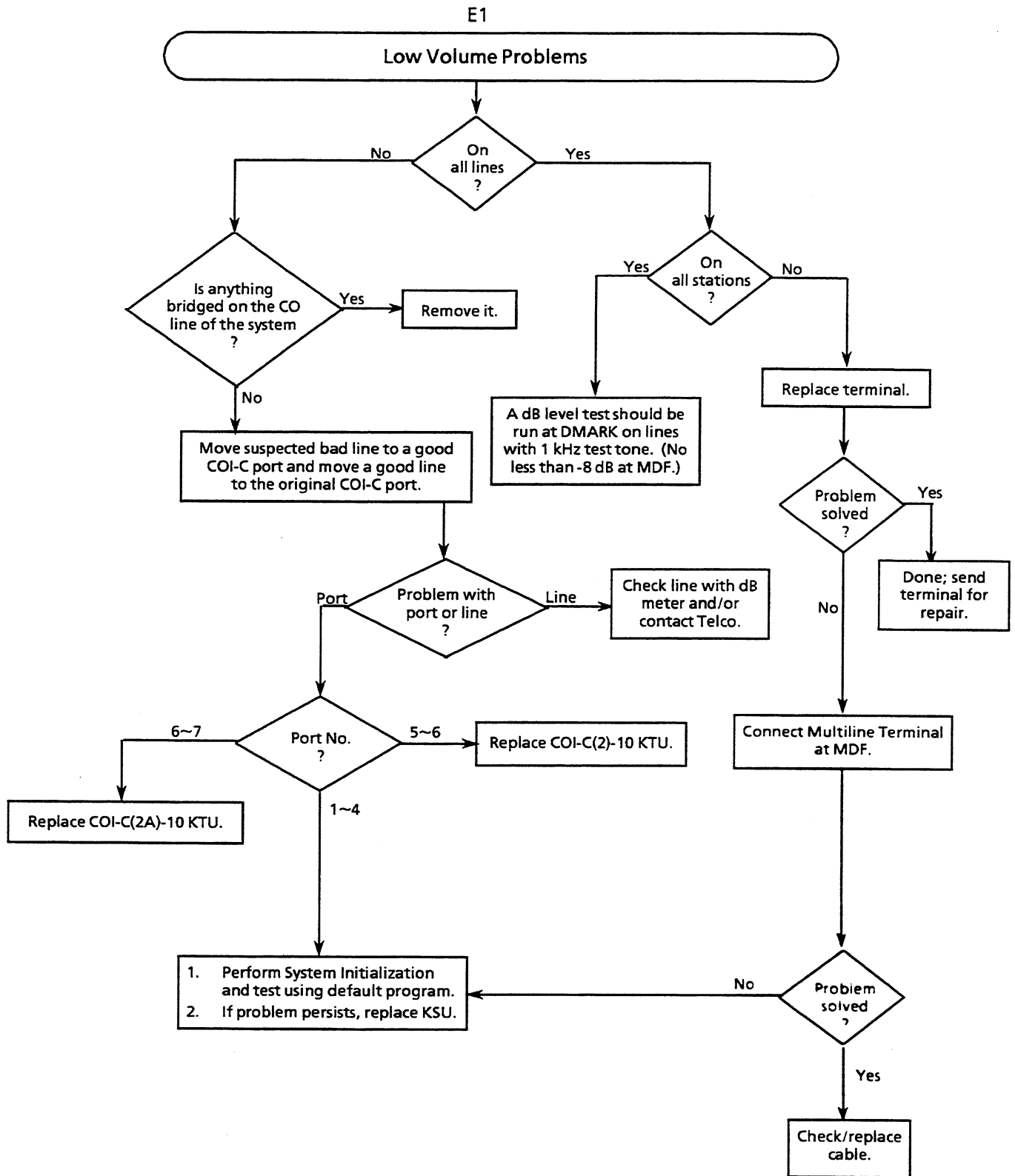

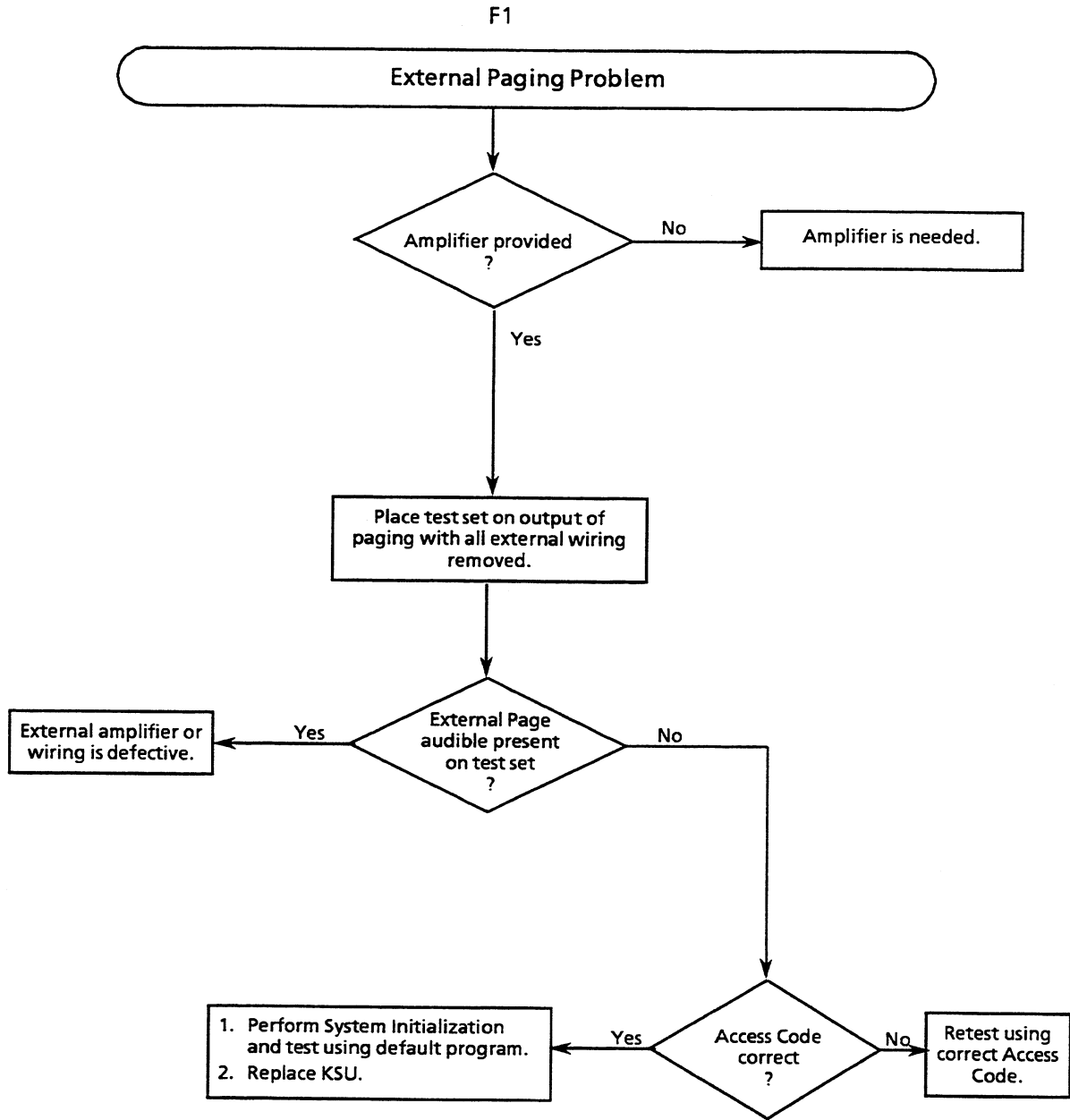

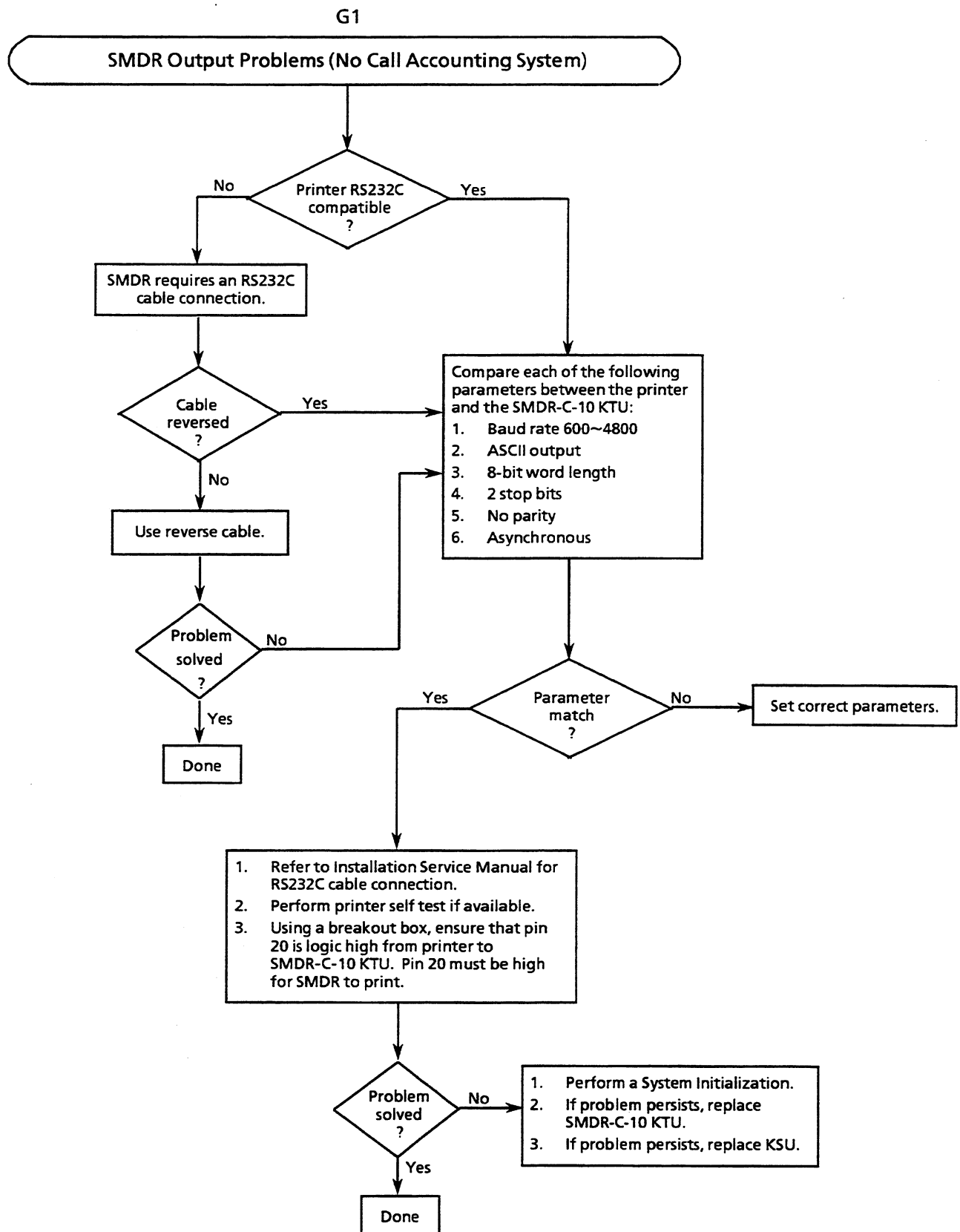

THIS PAGE INTENTIONALLY LEFT BLANK

CHAPTER 4

ELECTRA ELITE TERMINAL

UPGRADE

CHAPTER 4

ELECTRA ELITE TERMINAL UPGRADE

TABLE OF CONTENTS

COMPARISONS.....	4-1
POWER REQUIREMENTS	4-2
OPERATING PROCEDURES	4-2
PROGRAMMING	4-3
ELECTRA ELITE TERMINALS.....	4-3
INSTALLING ELECTRA ELITE TERMINALS	4-5
ELECTRA ELITE ADAPTERS	4-5
ADA-U UNIT (ANCILLARY DEVICE ADAPTER).....	4-5
Installing an ADA-U Unit on a Multiline Terminal.....	4-5
Connecting Cables to the ADA-U Unit.....	4-8
Switch Settings on the ADA-U Unit	4-11
APR-U-UNIT (ANALOG PORT RINGER).....	4-12
Installing an APR-U Unit on a Multiline Terminal	4-13
HFU-U UNIT (HANDSFREE UNIT).....	4-15
Installing an HFU-U Unit on a Multiline Terminal	4-16
Installing the External Microphone	4-16
WALL MOUNTING	4-18
Removing and Remounting the Handset Hanger	4-18
Wall Mounting Using the Base Unit	4-18
Installing the Wall Mount Unit and Mounting the Multiline Terminal Using the WMU-U Unit.....	4-23
Removing the Multiline Terminal from the Base Unit or the WMU-U Unit ...	4-26

LIST OF FIGURES

Figure 4-1	Electra Elite Multiline Terminals	4-4
Figure 4-2	Removing the Tilt Panel on the Multiline Terminal	4-5
Figure 4-3	Removing the Cover on the Multiline Terminal	4-6
Figure 4-4	Opening the Cover on the Multiline Terminal	4-6
Figure 4-5	Attaching the ADA-U Unit to the Multiline Terminal	4-7
Figure 4-6	Leading the Telephone Cord out from the ADA-U Unit.	4-7
Figure 4-7	ADA-U Unit	4-8
Figure 4-8	Attaching Cables to the ADA-U Unit	4-8
Figure 4-9	ADA-U Unit Switch Settings	4-11
Figure 4-10	APR-U Unit.	4-12
Figure 4-11	Raising the Tilt Panel	4-13
Figure 4-12	Removing the Cover on the Multiline Terminal	4-13
Figure 4-13	Attaching the Unit to the Multiline Terminal	4-14
Figure 4-14	Leading the AC Adapter Cord out from the Unit	4-14
Figure 4-15	Closing the Tilt Panel Cover	4-15
Figure 4-16	HFU-U Unit.	4-16
Figure 4-17	Microphone with Mute	4-16
Figure 4-18	Attaching a Microphone to a Multiline Terminal	4-17
Figure 4-19	Positioning the Handset Hanger	4-18
Figure 4-20	Removing the Base Unit	4-18
Figure 4-21	Removing the Knockout	4-19
Figure 4-22	Attaching the Base Unit to the Wall	4-19
Figure 4-23	Wall Mounting Using a Modular Jack.	4-20
Figure 4-24	Plugging in the Line Cord Using a Wall Jack.	4-20
Figure 4-25	Plugging in the Line Cord Using a Modular Jack.	4-21
Figure 4-26	Attaching the Bottom Tabs of the Multiline Terminal to the Base Unit	4-21
Figure 4-27	Attaching the Top Tabs of the Multiline Terminal to the Base Unit	4-22
Figure 4-28	Install Wall Mount Unit.	4-22

LIST OF FIGURES Continued

Figure 4-29	Removing the Tabs from the Adapter	4-23
Figure 4-30	Removing the Tabs from the WMU-U Unit	4-23
Figure 4-31	Leading the Line Cord out of the WMU-U Unit.	4-24
Figure 4-32	Attaching the Wall Mount Unit to the Wall.	4-24
Figure 4-33	Attaching the Multiline Terminal to the WMU-U Unit	4-25
Figure 4-34	Removing the Multiline Terminal from the Base Unit or the WMU-U Unit . . .	4-26

LIST OF TABLES

Table 4-1 Multiline Terminal Loop Resistance and Cable Length 4-2

Table 4-2 ADA-U Cable Connections 4-9

Table 4-3 ADA-U Unit Switch Settings 4-11

Table 4-4 HFU-U Unit Switch Settings 4-17

CHAPTER 4

ELECTRA PROFESSIONAL LEVEL I ELECTRA ELITE TERMINAL UPGRADE

The Electra Professional Level I system supports Electra Elite Multiline Terminals with a software upgrade. Software version 4.00 is required for the Electra Professional Level I system. No system hardware changes are required to accommodate the Electra Elite Multiline Terminals; the current ESI card will support both the Electra Professional and Electra Elite Multiline Terminals. Minor station wiring changes are required when using the Electra Elite terminals; these terminals use the green/red wires at the wall jack.

COMPARISONS

The Electra Professional telephones and the Electra Elite telephones have similar capabilities. However, there are a few differences which are listed below:

- Ⓒ Electra Elite Multiline Terminals use the green/red pair at the wall jack instead of the yellow/black pair used with the Electra Professional Multiline Terminals.
- Ⓒ The Electra Professional ETW-8-1 and Electra Elite DTU-8-1 have the same line capacities.
- Ⓒ The Electra Professional ETW-16DC-1 and Electra Elite DTU-16D-1 have the same line capacities.
- Ⓒ The Electra Elite DTU-32D-1 has four fewer One-Touch keys when compared to the ETW-16DD-1.
- Ⓒ The Electra Elite Multiline Terminal provides the full-duplex speakerphone option with push-to-mute capability.
- Ⓒ The Electra Elite Multiline Terminal has a built-in headset jack.
- Ⓒ The Electra Elite Multiline Terminal has a built-in wall mount unit.
- Ⓒ The Electra Elite Multiline Terminal has a longer handset cord (12 feet).
- Ⓒ The Electra Elite Multiline Terminal has snap-in option units for easy installation.
- Ⓒ The **FNC** Key on the Electra Professional Multiline Terminal performs the same operation as the **Feature** key on the Electra Elite Multiline Terminal.
- Ⓒ The **LNR/SPD** Key on the Electra Professional Multiline Terminal performs the same operation as the **Redial** key on the Electra Elite Multiline Terminal.
- Ⓒ The Off-Hook Voice Announce feature is only available with the ETW-24DS-1 telephone.
- Ⓒ Handset/Headset Mute is not supported on Electra Elite terminals.

- Ⓒ The Electra Elite Multiline Terminal display adjusts to a greater angle.
- Ⓒ The Electra Elite Multiline Terminal has a matte finish.
- Ⓒ The D^{term} PC TAPI Board does not work with the Electra Elite terminals when used with the Electra Professional Level I system.

POWER REQUIREMENTS

The KSU is connected with each of the Multiline Terminals and Single Line Telephones by a separate twisted 1-pair cable or 2-pair cable (only for Multiline Terminals).

Table 4-1 Multiline Terminal Loop Resistance and Cable Length

Terminal or Adapter	Maximum Loop Resistance (Ohms)	Maximum Feet by Twisted 1-Pair Cable	Maximum Feet by Twisted 2-Pair Cable
		24 AWG	24 AWG
DTU-8-1 (WH)/(BK) TEL	35	600	1000
DTU-16-1 (WH)/(BK) TEL	26	450	900
DTU-16D-1 (WH)/(BK) TEL	26	450	900
DTU-32-1 (WH)/(BK) TEL	21	360	720
DTU-32-D-1 (WH)/(BK) TEL	21	360	720
DCU-60-1 (WH)/(BK) CONSOLE	N/A	1000	1000

Note: When installing an Attendant Console (DCU-60-1), an AC Adapter is required.

OPERATING PROCEDURES

The operating procedures are the same for the Electra Professional and Electra Elite Multiline Terminals. There are two minor changes:

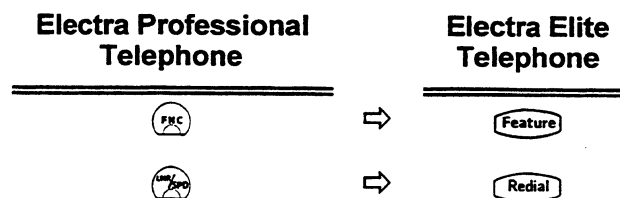

PROGRAMMING

The programming procedures for the Electra Professional Multiline Terminals and the Electra Elite Multiline Terminals are the same.

ELECTRA ELITE TERMINALS

All digital Multiline Terminals are equipped with:

- Ⓢ Programmable Line Keys (each with a two-color LED)
- Ⓢ Built-in Speakerphone
- Ⓢ Headset Jack
- Ⓢ Wall Mount Unit
- Ⓢ Large LED to indicate calls and messages
- Ⓢ Snap-in options: ADA-U Unit, APR-U Unit, and HFU-U Unit

The maximum of 16 of all terminal types can be installed in an Electra Professional system.

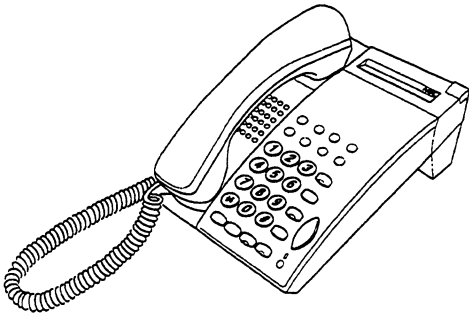

DTU-8-1 (BK)/(WH) TEL
8-Line Nondisplay

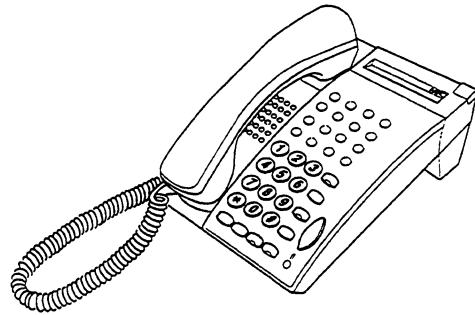

DTU-16-1 (BK)/(WH) TEL
16-Line Nondisplay

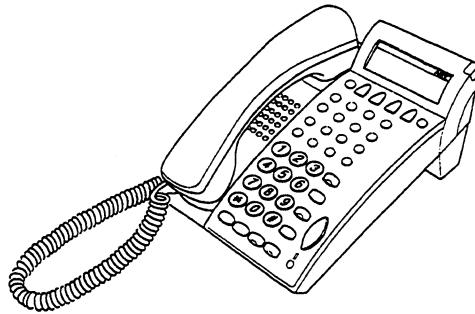

DTU-16D-1 (BK)/(WH) TEL
16-Line Display

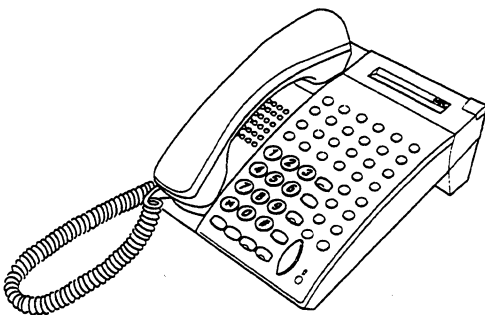

DTU-32-1 (BK)/(WH) TEL
16-Line Nondisplay with 16
Programmable One-Touch Keys

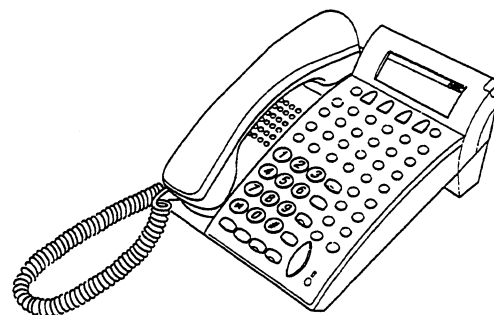

DTU-32D-1 (BK)/(WH) TEL
16-Line Display with 16
Programmable One-Touch Keys

Figure 4-1 Electra Elite Multiline Terminals

INSTALLING ELECTRA ELITE TERMINALS

When installing the Electra Elite Multiline Terminals, use the **green/red** pair at the wall jack instead of the yellow/black pair used with the Electra Professional Multiline Terminals.

ELECTRA ELITE ADAPTERS

ADA-U UNIT (ANCILLARY DEVICE ADAPTER)

Ancillary Device Adapters allow connection of a tape recorder for logging/recording telephone calls to Electra Elite Multiline Terminals.

A dedicated set of input connectors is also provided for a recording tone unit to inform the parties that the call is being recorded.

When installing an ADA-U Unit, connect the cables to the ADA-U Unit, set the dip switches, and then install the ADA-U Unit on the Multiline Terminal. The ADA-U Unit **does not** require an AC Adapter.

Installing an ADA-U Unit on a Multiline Terminal

1. Unplug the telephone cord from the Multiline Terminal.
2. Press both the left and right ends of the tilt panel found on the back of the Multiline Terminal and remove it.

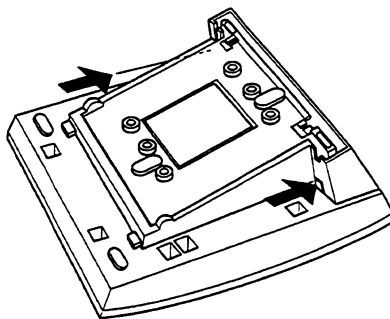

Figure 4-2 Removing the Tilt Panel on the Multiline Terminal

3. Remove the cover by pressing the areas indicated in Figure 4-3 Removing the Cover on the Multiline Terminal. Using a straight blade screwdriver, press the blade between the cover and the base to release the tabs (refer to the diagram). When both tabs are released, lift the cover.

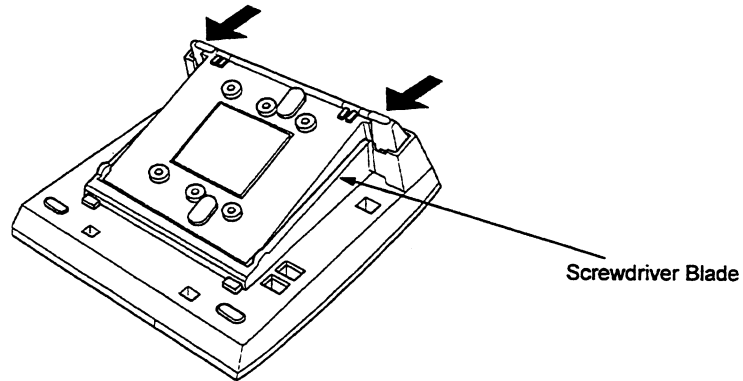

Figure 4-3 Removing the Cover on the Multiline Terminal

4. Open the cover to allow access to the ADA receptacle.

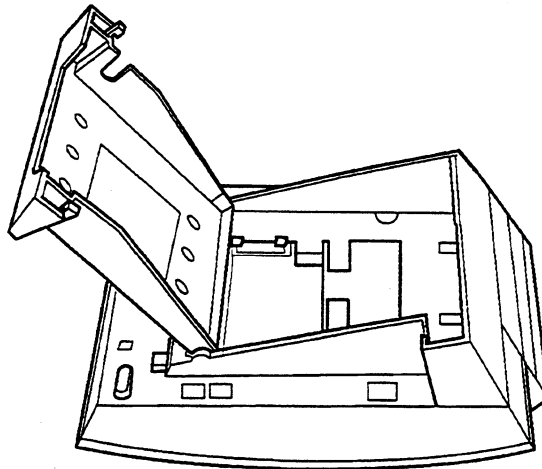

Figure 4-4 Opening the Cover on the Multiline Terminal

5. Plug the ADA-U Unit connector into the receptacle connector located on the back of the Multiline Terminal (marked Connector in the diagram). Snap the ADA-U Unit between the hooks (marked Hook on the diagram) on the Multiline Terminal to secure it.

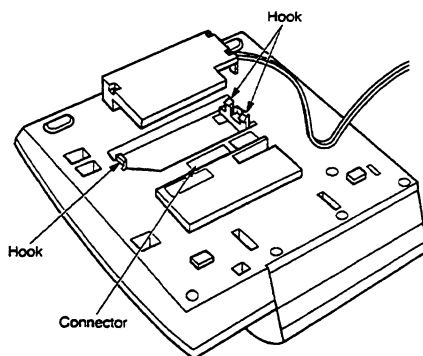

Figure 4-5 Attaching the ADA-U Unit to the Multiline Terminal

6. Lead the telephone cord out through the groove on the tilt panel. Plug in the telephone cord.

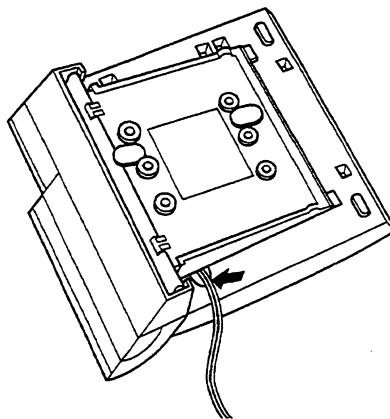

Figure 4-6 Leading the Telephone Cord out from the ADA-U Unit

Connecting Cables to the ADA-U Unit

Cable terminal connectors are located on the right side of the ADA-U Unit. Cables should be connected on this unit before installing the unit on the Multiline Terminal.

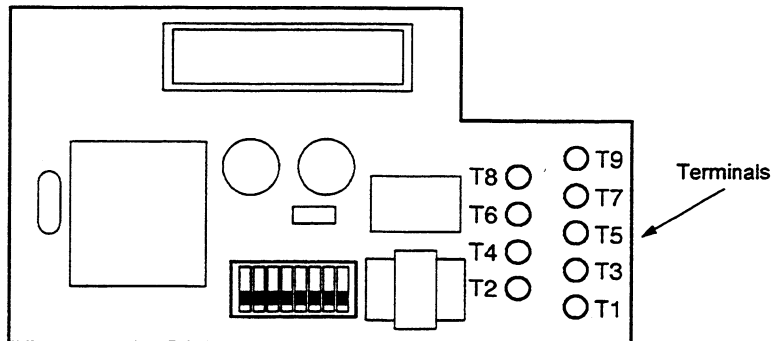

Figure 4-7 ADA-U Unit

1. Cut off the plug on one end of the cable.
2. Locate the adapter terminals on the right side of the unit as illustrated in Figure 4-7 ADA-U Unit.
3. Remove the cap on the adapter terminal exposing the metal receptacle. Push the cable into the appropriate receptacle and replace the cap. Be sure to line up the slot on the cap with the slot on the metal receptacle to ensure proper contact. (Refer to Figure 4-8 Attaching Cables to the ADA-U Unit.)

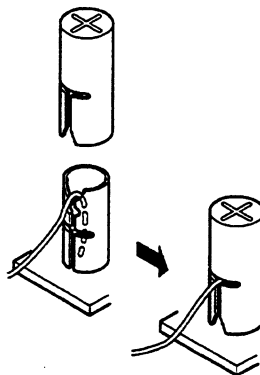

Figure 4-8 Attaching Cables to the ADA-U Unit

4. Insulate the end of the cable that needs to be shielded with insulating tape.

Table 4-2 ADA-U Cable Connections provides a list of cable connections to ADA-U ADP terminals and describes the specifications for the terminals.

Table 4-2 ADA-U Cable Connections

Terminal Number	Cables to Connect	Terminal Specifications
T1	Connect to T3 and T4. (T1 and T2 are used as input from a recording input generator. They are input-only and provide an audio path to the recording device when connected to T3 and T4.)	Input Terminal: Terminal is enabled only when DIP switches 3 and 4 are OFF. (If switches 3 and 4 are ON, a humming sound may be recorded due to impedance mismatch.) Input Impedance: 100K Ω Input Level: -15 dB ~ 40 dB (approximately)
T2		
T3	Connect the audio recording cable (2-way path).	Input/Output Terminal: To switch between line jack and mic jack on the recorder, set impedance DIP switches 5 and 6 to ON.
T4	Connect the shielded end of the audio recording cable (2-way path).	Line jacks or other similar (600 Ω) devices: Input/Output Level:-15 dB ~ 40 dB (approximately) Mic jacks or other similar low impedance devices: Input/Adapter Level:-40 dB ~ 60 dB (approximately)
T5	Connect the bare end of the control cable.	When a Multiline Terminal is idle, this contact is open. When the Multiline Terminal goes off-hook (using the handset, headset, or built-in speakerphone), this contact is closed. With the open contact, use both T5 and T6.
T6	Connect the shielded end of the control cable.	This provides common connection for control cable.
T7	Connect the bare end of the control cable.	When the Multiline Terminal is idle, this contact is closed. When the Multiline Terminal is busy (using the handset, headset, or built-in speakerphone), this contact is open. With the closed contact, use both T6 and T7.
T8	Connect to Off-Hook Control Lead A	A short between T8 and T9 causes the Multiline Terminal to go off-hook and send audio to T3 and T4.
T9	Connect to Off-Hook Control Lead B	

Table 4-2 ADA-U Cable Connections (Continued)**Notes:**

- * When the built-in microphone is used for recording purposes, a low recording level may occur for the transmit portion of the conversation.
- * When recording in handsfree (half-duplex) mode using the built-in speakerphone, the record notice tone may not be audible to the far-end party and/or speech may be interrupted or distorted when the tone is generated.
- * The transmit recording level is lower than the receiving voice level for intercom calls. The transmit recording levels for CO calls are matched.
- * If the record tone generator is separate from the recorder, a separate pair of cables is required. For this configuration, connect the record notice tone cables to input terminals T1 and T2 on the ADA-U. (T3 and T4 are used as the tape recorder input.)
- * If a remote control terminal is provided on a recorder and a control cable is used, the record start/stop control is provided by connecting the terminal to T5 (or T7) and T6 on the ADA-U. (Connecting to T5 or T7 is determined by the specifications of the recorder.)
- * If a Beep Tone is provided from the recording equipment, the Beep Tone should be input via T3 and T4 on ADA-U ADP. (Do not use T1 and T2 to input Beep Tone.)
- * Single Line Telephones that are connected to an APR-U Unit cannot be used to record conversations via the ADA-U Unit.

Switch Settings on the ADA-U Unit

The DIP switch is located at the bottom center of the ADA-U Unit. The DIP switch allows a technician to configure the board to specific settings. Figure 4-9 ADA-U Unit Switch Settings shows the default settings.

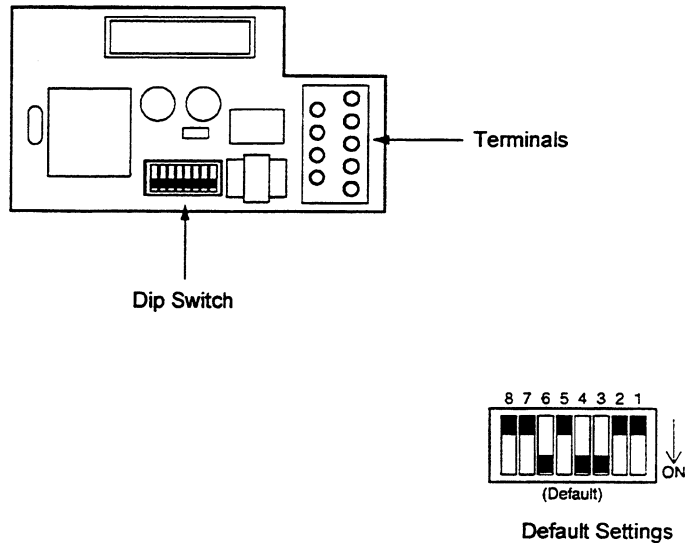

Figure 4-9 ADA-U Unit Switch Settings

The following switch settings should be made on the ADA-U Unit to enable or disable the record start notice tone. Switch settings should be made before installing the ADA-U Unit in the Multiline Terminal. (Refer to Table 4-3 ADA-U Unit Switch Settings.)

Table 4-3 ADA-U Unit Switch Settings

Switch	Setting		Description
SW1-1	ON		Enables the relay control at T5, T6 or T6, T7
SW1-2	OFF		N/A
SW1-3 and SW1-4	SW1-3 ON	SW1-4 ON	Beep Tone provided by the recording device, connected by T3 and T4 (Do not connect T1 and T2)
	SW1-3 OFF	SW1-4 OFF	Beep Tone provided by an external devices, connected by T1 and T2

Note: Do not connect T1 and T2 when switches 3 and 4 are ON.

Table 4-3 ADA-U Unit Switch Settings (Continued)

Switch	Setting		Description
SW1-5 and SW1-6	SW1-5 OFF	SW1-6 ON	Input impedance for T5 and T6 are set to 600 Ω
	SW1-5 ON	SW1-6 OFF	Input impedance for T5 and T6 are set to 30 Ω
SW1-7	ON		Enables the record tone input
SW1-8	OFF		N/A

Note: Do not connect T1 and T2 when switches 3 and 4 are ON.

APR-U UNIT (ANALOG PORT RINGER)

The Analog Port Adapter with Ringing provides an interface for installing Single Line Telephones, modems, and NEC VoicePoint/VoicePoint Plus Conferencing unit. The APR-U Unit also detects incoming ringing signals. By providing ring detection, the user can install a personal fax machine or an answering machine for convenience. Two user-adjustable switches are provided on the adapter; one allows for 600 ohms or a complex impedance interface to devices such as a modem or Single Line Telephone, the second switch (SW1) is set to position 2 (the Electra Professional System does not support the B2 channel). The APR-U **requires** an AC Adapter, which is ordered separately. If an APR-U and HFU-U are both installed, only one AC Adapter is required.

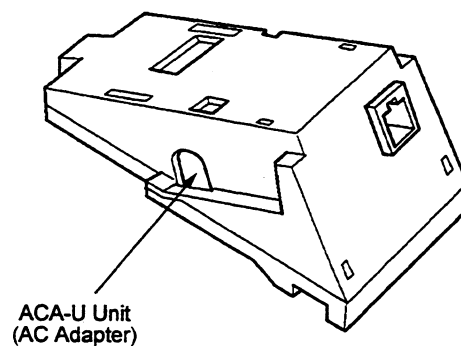

Figure 4-10 APR-U Unit

Installing an APR-U Unit on a Multiline Terminal

1. Unplug the telephone cord from the Multiline Terminal.
2. On the back of the Multiline Terminal, press the areas indicated in the diagram to raise the inner area of the tilt panel.

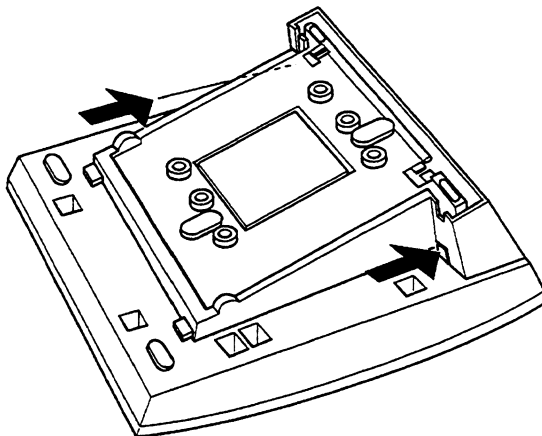

Figure 4-11 Raising the Tilt Panel

3. Remove the cover by pressing the areas indicated by arrows in Figure 4-12 Removing the Cover on the Multiline Terminal. Using a straight blade screwdriver, press the blade between the cover and the base to release the tabs (refer to the diagram). When both tabs are released, lift the cover.

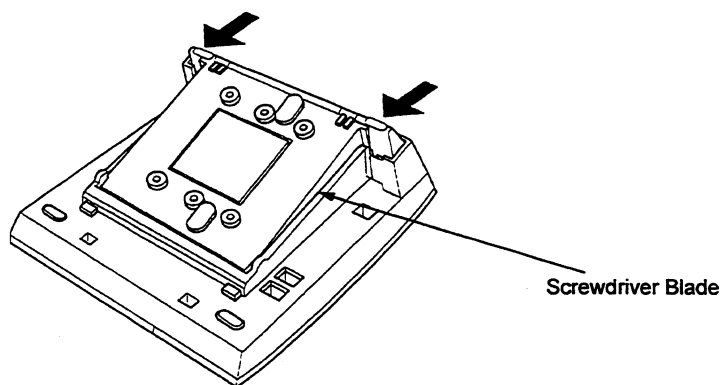

Figure 4-12 Removing the Cover on the Multiline Terminal

4. Plug the receptacle connector on the unit into the receptacle connector inside the tilt panel on the Multiline Terminal. Refer to Figure 4-13 Attaching the Unit to the Multiline Terminal.

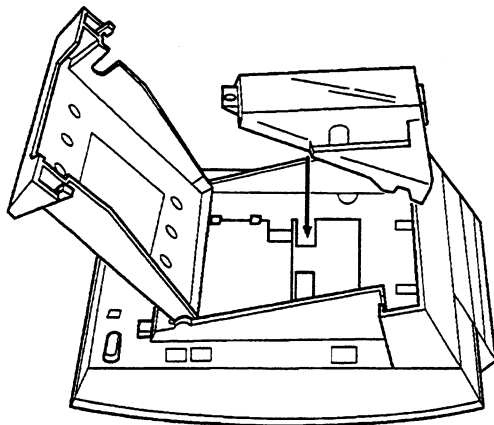

Figure 4-13 Attaching the Unit to the Multiline Terminal

5. Plug the cord of the ACA-U Unit into the jack on the APR-U Unit. (The ACA-U Unit is a separate unit that can be purchased from NEC.) Lead the AC Adapter cord out through the groove in the base as shown in Figure 4-14 Leading the AC Adapter Cord out from the Unit.

When connecting the AC Adapter (ACA-U Unit), connect it to the device in the left side of the adapter bay. Refer to Figure 4-14 Leading the AC Adapter Cord out from the Unit. This allows the ACA-U Unit to supply power to all devices installed in the adapter bay.

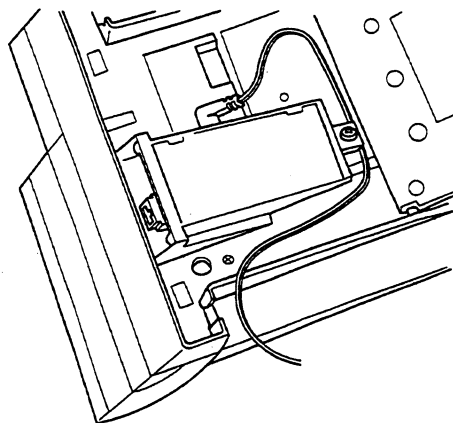

Figure 4-14 Leading the AC Adapter Cord out from the Unit

6. Close the tilt panel cover, lead the AC adapter cord out through the hole and snap the cover in place.

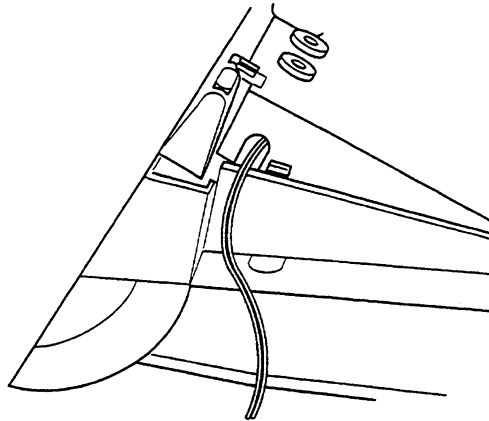

Figure 4-15 Closing the Tilt Panel Cover

7. Plug in the power cord on the AC adapter and the telephone cord in the jack.

HFU-U Unit (Handsfree Unit)

The Handsfree Unit provides a solution for small office teleconferencing by improving the sound quality of speakerphone calls via an external microphone. This unit is useful in a working environment where handsfree calling is a necessity. To provide maximum performance, two user-adjustable switches are available that allow the speakerphone to be configured for the customer's environment (quiet room, noisy business environment, or a room with an acoustic echo). A push-to-mute button is featured on the external microphone to add privacy for handsfree dialing. The HFU-U **requires** an AC Adapter, which is ordered separately. If an APR-U and HFU-U are both installed, only one AC Adapter is required.

Note: This unit is designed to enhance the handsfree operation of a Multiline Terminal by providing an echo canceling circuit. However, this unit is primarily designed for a typical small office environment and not for conference rooms. Its performance should not be compared to commercial audio conference units. Also, calls may not be recorded when using the HFU-U.

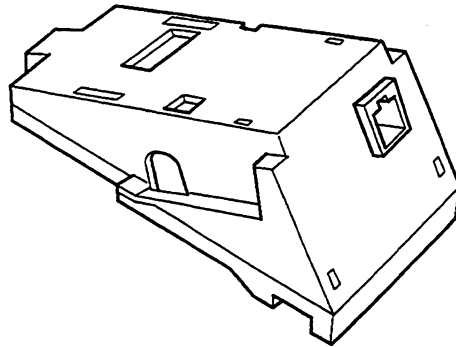

Figure 4-16 HFU-U Unit

Installing an HFU-U Unit on a Multiline Terminal

Refer to Installing an APR-U Unit on a Multiline Terminal on page 13. The instructions for installing the HFU-U Unit and the APR-U Unit are the same.

Installing the External Microphone

An external microphone can be installed on the HFU-U Unit. These instructions apply to the external microphone included with the HFU-U Unit. This microphone is equipped with a push-to-mute button.

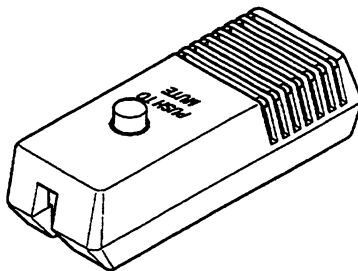

Figure 4-17 Microphone with Mute

1. Plug the microphone cord into the jack on the HFU-U Unit as shown in Figure 4-18 Attaching a Microphone to a Multiline Terminal.

☞ The microphone should be located at least two feet away from the Multiline Terminal.

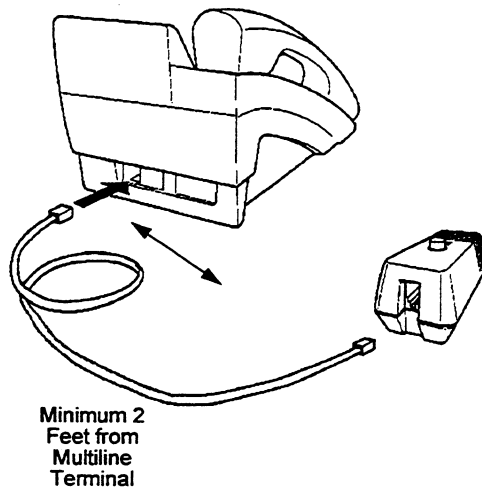

Figure 4-18 Attaching a Microphone to a Multiline Terminal

2. Set the switches on the HFU-U Unit as indicated in Table 4-4 HFU-U Unit Switch Settings.

Table 4-4 HFU-U Unit Switch Settings.

Switch	Position	Switch	Position	Setting
SW1	2	SW2	2	Full Duplex
SW1	1	SW2	2	Half Duplex 6 dB Attenuation
SW1	2	SW2	1	Half Duplex 12 dB Attenuation
SW1	1	SW2	1	Half Duplex 18 dB Attenuation

Wall Mounting

Any Electra Elite Multiline Terminal can be mounted on a wall. There are two ways a Multiline Terminal can be wall mounted: using the base unit that comes with the Multiline Terminal or using the WMU-U Unit to accommodate adapters that are installed on the Multiline Terminal.

Removing and Remounting the Handset Hanger

1. Remove the hanger by sliding it out of the slot. Remount it back into its original position so that the hanger protrudes providing a rest for the handset. (This procedure applies when using either the base unit or the WMU-U Unit.) Refer to Figure 4-19 Positioning the Handset Hanger for the steps for removing and remounting the handset hanger.

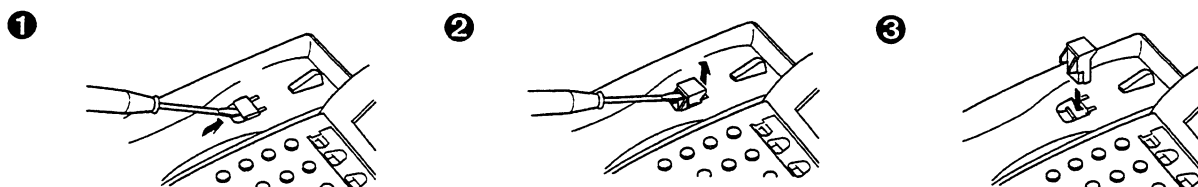

Figure 4-19 Positioning the Handset Hanger

Wall Mounting using the Base Unit

1. Remove the base unit by pressing the tabs on each side of the base plate and lifting upward.

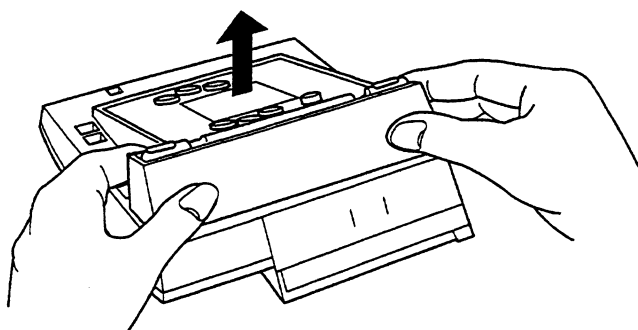

Figure 4-20 Removing the Base Unit

2. Remove the knockout on the base unit with nippers. In Figure 4-21 Removing the Knockout, the shaded area indicates the knockout.

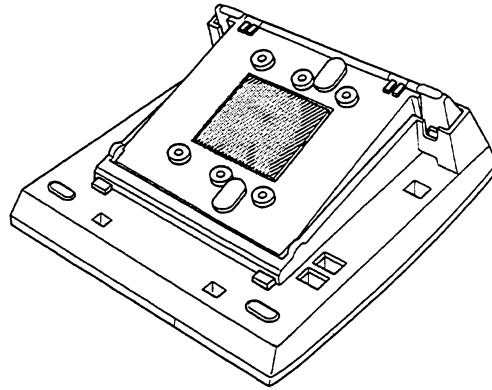

Figure 4-21 Removing the Knockout

3. Attach the base unit to the posts on the wall plate (locally provided). Using locally provided screws, secure the base unit to the wall. Place the screws in the nodes provided on the base unit. (Place the wider end of the base unit down.) Attach the base unit to the wall plate as illustrated in Figure 4-22 Attaching the Base Unit to the Wall.

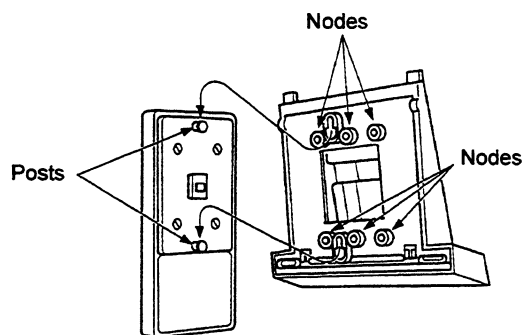

Figure 4-22 Attaching the Base Unit to the Wall

If using a modular jack instead of a wall plate, put the modular jack inside the base unit as shown in Figure 4-23 Wall Mounting Using a Modular Jack. Use the locally provided screws to attach the base unit directly to the wall.

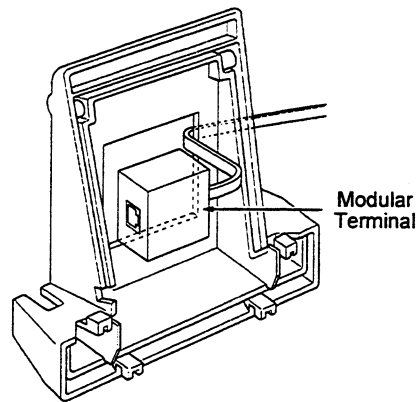

Figure 4-23 Wall Mounting Using a Modular Jack

4. Plug the line cord into the jack on the wall plate, wrap the extra cord and secure it with a tie wrap, and lead the line cord out through the groove in the side of the base unit.

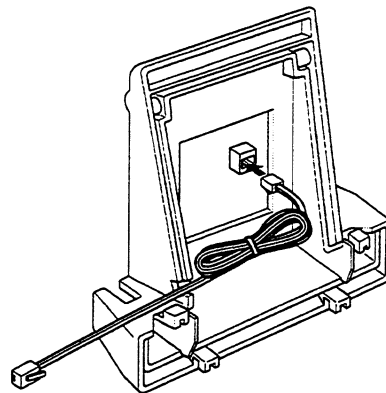

Figure 4-24 Plugging in the Line Cord Using a Wall Jack

If using a modular jack instead of a wall plate, plug the line cord into the modular jack, wrap the extra cord and secure it with a tie wrap, and lead the line cord out through the groove in the side of the base unit.

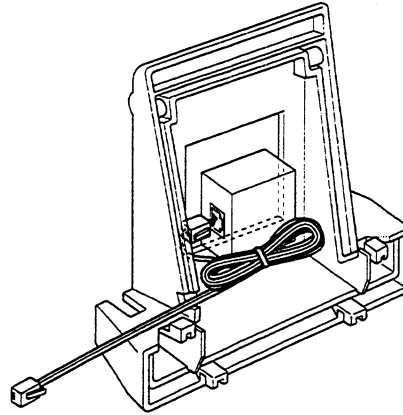

Figure 4-25 Plugging in the Line Cord Using a Modular Jack

5. With the base unit attached to the wall, hook to the two bottom tabs on the base unit into the tab slots on the Multiline Terminal.

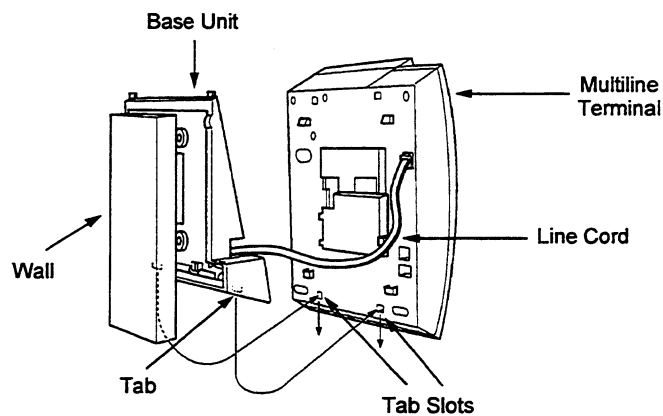

Figure 4-26 Attaching the Bottom Tabs of the Multiline Terminal to the Base Unit

6. Push up on the Multiline Terminal and lock the top tabs on the base unit into the tab slots on the Multiline Terminal. Figure 4-27 Attaching the Top Tabs of the Multiline Terminal to the Base Unit illustrates how the Multiline Terminal is attached.

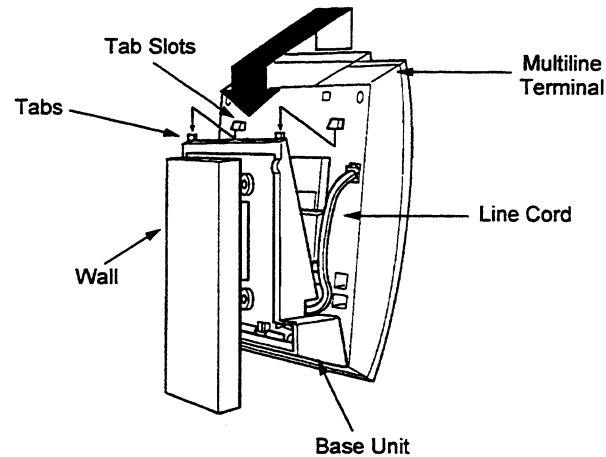

Figure 4-27 Attaching the Top Tabs of the Multiline Terminal to the Base Unit

7. When properly installed, the wall mounted Multiline Terminal looks similar to the one illustrated in Figure 4-28 Installed Wall Mount Unit.

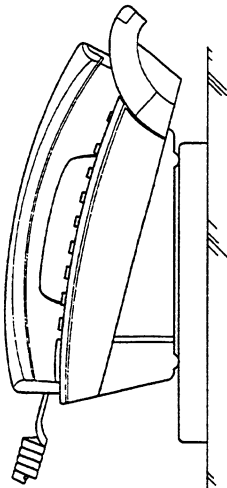

Figure 4-28 Installed Wall Mount Unit

Note: Do not adjust the tilt panel after the Multiline Terminal has been mounted on the wall.

Installing the Wall Mount Unit and Mounting the Multiline Terminal using the WMU-U Unit

If installing an ADA-U Unit, APR-U Unit, HFU-U Unit, a separate WMU-U Unit must be purchased to accommodate the additional space required for these units.

1. Remove the line cord and the tilt leg from the Multiline Terminal. Cut off the tabs on the adapter as shown in Figure 4-29 Removing the Tabs from the Adapter.

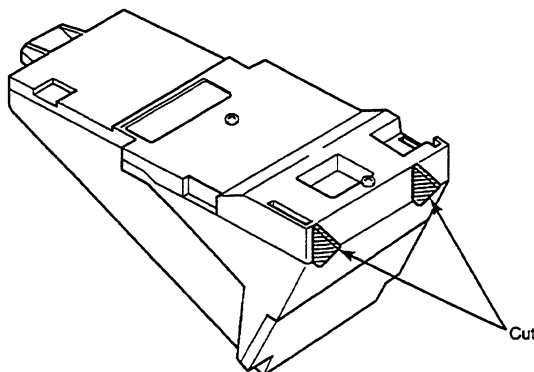
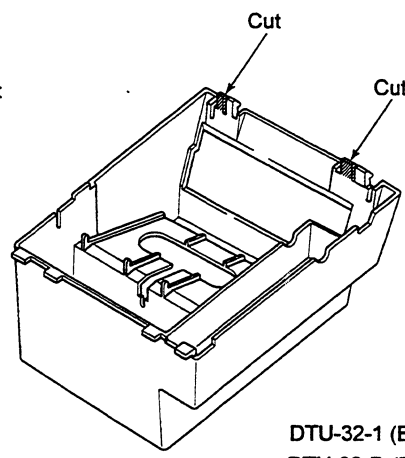
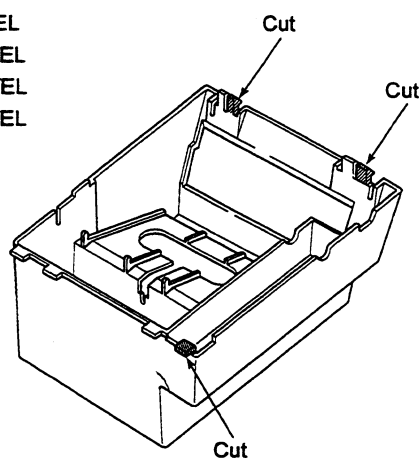

Figure 4-29 Removing the Tabs from the Adapter

2. Remove the tabs from the WMU-U Unit as shown in Figure 4-30 Removing the Tabs from the WMU-U Unit. (The tabs that are removed depends on the Multiline Terminal type.)

DTU-8-1 (BK)/(WH) TEL
 DTU-16-1 (BK)/(WH) TEL
 DTU-16-D (BK)/(WH) TEL
 DCU-60-1 (BK)/(WH) TEL



DTU-32-1 (BK)/(WH) TEL
 DTU-32-D (BK)/(WH) TEL

Figure 4-30 Removing the Tabs from the WMU-U Unit

3. Bundle the cord from the modular jack leaving approximately eight inches. Use a tie wrap to secure the bundled cord.
4. Place the bundled line cord in the space between the WMU-U Unit and the wall. Lead the line cord out through the slits as shown in Figure 4-31 Leading the Line Cord out of the WMU-U Unit.

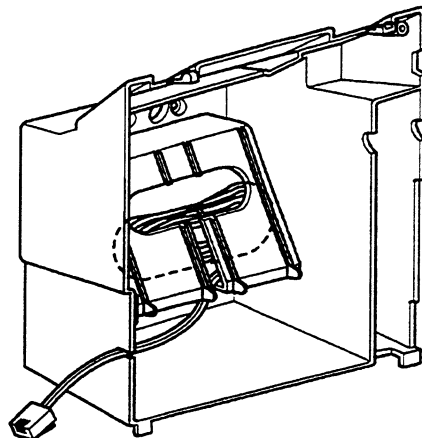

Figure 4-31 Leading the Line Cord out of the WMU-U Unit

5. Attach the WMU-U Unit to the posts on the wall plate (locally provided). Using locally provided screws secure the WMU-U Unit to the wall. Place the screws in the nodes on the WMU-U Unit.

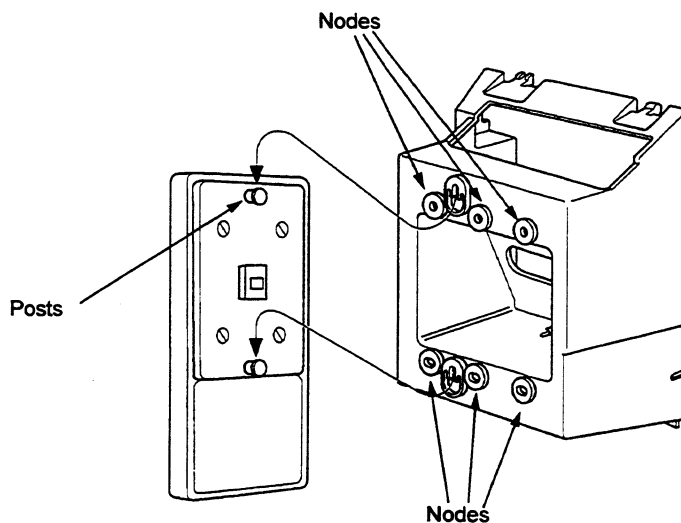

Figure 4-32 Attaching the Wall Mount Unit to the Wall

6. Connect the line cord to the Multiline Terminal.
7. With the WMU-U Unit attached to the wall, hook the two bottom tabs on the WMU-U Mount Unit into the tab slots on the Multiline Terminal. Then push the two top tabs on the WMU-U Unit into the tab slots on the Multiline Terminal. If the adapter has a power supply, lead the AC adapter cord out through the opening at the bottom of the Multiline Terminal. Refer to Figure 4-33 Attaching the Multiline Terminal to the WMU-U Unit.

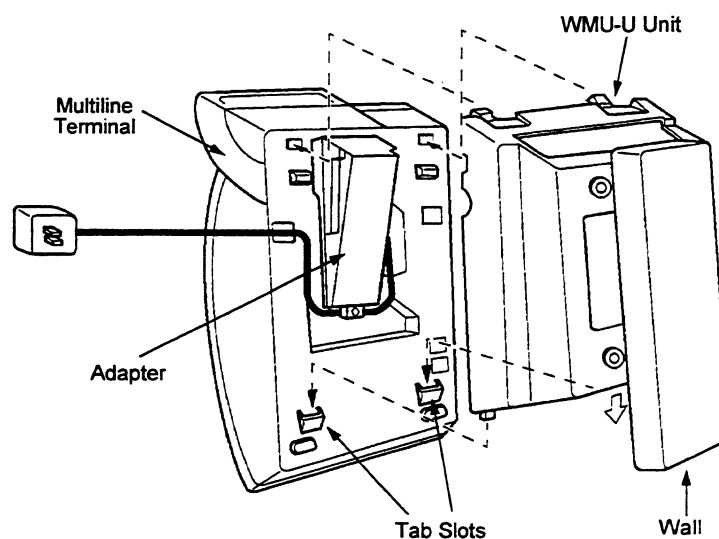

Figure 4-33 Attaching the Multiline Terminal to the WMU-U Unit

Removing the Multiline Terminal from the Base Unit or the WMU-U Unit

To remove the Multiline Terminal from the base unit or WMU-U Unit, pull up on the bottom of the Multiline Terminal and lift the terminal from the base unit or WMU-U Unit.

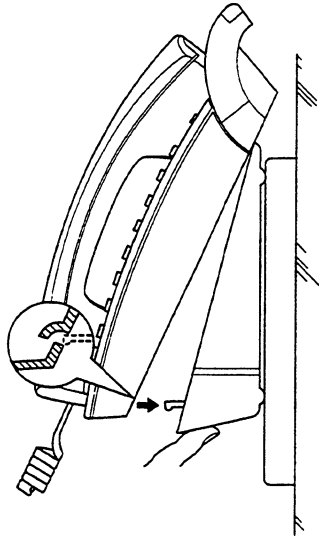

Figure 4-34 Removing the Multiline Terminal from the Base Unit or WMU-U Unit

CHAPTER 5

SERIES 500

FEATURES AND SPECIFICATIONS

CHAPTER 5

SERIES 500

FEATURES AND SPECIFICATIONS

SECTION 1 INTRODUCTION 5-1

SECTION 2 FEATURES..... 5-1

 All Call Page 5-3

 Delayed Ringing to Voice Mail..... 5-5

 Do Not Disturb 5-7

 Handset Microphone Control 5-9

 Microphone Control 5-11

 Softkeys..... 5-13

CHAPTER 5

SERIES 500 FEATURES AND SPECIFICATIONS

SECTION 1

Introduction

Series 500 software provides two new features and modifies several existing features to accommodate softkeys.

The two new features include:

D-1 Delayed Ringing to Voice Mail

S-5 Softkeys

The features that are modified to accommodate the use of softkeys include:

A-2 All Call Page

D-7 Do Not Disturb

H-1 Handset Microphone Control

M-1 Microphone Control

SECTION 2

Features

A description of each of the features for Series 500 is listed on the following pages.

THIS PAGE INTENTIONALLY LEFT BLANK

A-2 ALL CALL PAGE A-2**GENERAL DESCRIPTION**

The All Call Page feature allows simultaneous paging (internal and external) of all idle Multiline Terminals in a system over their built-in speakers and over the External Paging speaker. This enables a person, away from their desk but within hearing distance of a Multiline Terminal or external speaker, to respond to the paging call.

STATION APPLICATION

All station users can originate or answer an All Call Page. All Call Page can be received only at idle Multiline Terminals and the external paging speaker.

OPERATING PROCEDURE**To originate the page on a Multiline Terminal:**

1. Go off-hook and receive the internal dial tone (or press the **HOLD** key if the user is already engaged on a call).
2. Dial Access Code 77 for All Call Page.
3. Page.

To originate the page on a Multiline Terminal using softkeys (Series 500 or higher):

1. Go off-hook and receive the internal dial tone.
2. Press the **PAGE** softkey.
3. Page.

To answer the page on a Multiline Terminal:

1. Go off-hook.
2. Receive the internal dial tone.
3. Dial Meet-Me Access Code 7* or 7#; the display changes to show the originator station number.
4. Talk with the All Call Page originator.

To originate the page on a Single Line Telephone:

1. Lift handset or press hookswitch if the user is already engaged in a call.
2. Dial Access Code 77 for All Call Page.
3. Page.

To answer the page on a Single Line Telephone:

1. Lift the handset or press the hookswitch if the user is already engaged in a call.
2. Receive internal dial tone.
3. Dial Meet-Me Access Code 7* or 7#.
4. Talk with the All Call Page originator.

SERVICE CONDITIONS

- Stations can be allowed or denied access to paging through Class of Service. This includes All Call Page, Internal Zone Paging, and External Paging.
- Multiline Terminal users engaged in a handsfree call do not receive All Call Page or Internal Zone Page.
- Only one All Call Page or Internal Zone Page can be established at a time. Another page can be originated as soon as the first is abandoned or answered (by Meet-Me Answer).
- An All Call Page can be originated or answered (by Meet-Me Answer) from an internal dial tone.
- An All Call Page times out with a default time of 90 seconds.
- In System Programming, the paging alert tone can be allowed or denied on a system-wide basis. The default value is "Receive Paging Alert Tone."
- An External Page and an Internal Page can be accessed at the same time unless All Call Page is accessed.

D-1 DELAYED RINGING TO VOICE MAIL D-1**GENERAL DESCRIPTION**

When an incoming CO call first rings in to the system, it can be assigned to ring at a telephone or group of telephones. After a programmable elapsed time (maximum of 48 seconds), CO ringing to the telephones stops and ringing starts at the voice mail pilot number. This feature is used most often as a backup attendant.

STATION APPLICATION

Voice Mail ports only.

OPERATING PROCEDURE

Not applicable.

SERVICE CONDITIONS

- Delayed Ringing can only be assigned to Voice Mail ports.
- The Delayed Ringing timer is programmable (up to 48 seconds).
- Once the Delayed Ringing timer expires, the telephones assigned Day/Night ringing stops, and the pilot number for Voice Mail begins ringing.
- This features requires system software version 5.00 or higher.

THIS PAGE INTENTIONALLY LEFT BLANK

D-7 DO NOT DISTURB D-7**GENERAL DESCRIPTION**

The Do Not Disturb (DND) feature temporarily eliminates all audible signals for incoming calls to the station. This temporarily isolates the station from other stations in the system and allows the user time for more detailed or confidential work.

STATION APPLICATION

All Multiline Terminals.

OPERATING PROCEDURE**To set DND using a Multiline Terminal:**

1. Press the FNC key in idle mode.
2. Dial Access Code **60**.
3. Press the FNC key.

To cancel DND using a Multiline Terminal:

1. Press the FNC key in DND mode.
2. Dial Access Code **60**.
3. Press the FNC key.

To set/cancel DND using a Multiline Terminal with softkeys (Series 500 or higher):

1. Press the DND softkey.

SERVICE CONDITIONS

- The Do Not Disturb Set/Cancel Access Code can be programmed on a Feature Access key or One-Touch key with LED indication. The DND mode is also indicated on the FNC key LED.
- Recalls and Trunk queues override the DND setting.
- Setting DND eliminates audible signals such as incoming CO/PBX calls, incoming internal calls, off-hook ringing calls, paging, and Doorphone calls sent through the speaker.
- Voice announcements (in progress) continue to completion when the DND key is pressed during announcement. Subsequent voice announcements are eliminated.
- An internal call to a Multiline Terminal in DND mode results in a call waiting tone. The LCD on the calling party's Multiline Terminal displays an internal call.
- Callback Request can be set to a Multiline Terminal in DND mode.
- Automatic Callback cannot be set to a Multiline Terminal in DND mode.

- Station BGM can be accessed for Multiline Terminals in Do Not Disturb.
- Multiline Terminals in DND mode cannot be tone-overridden by another station (excluding Attendant Multiline Terminals if programmed).

H-1 HANDSET MICROPHONE CONTROL H-1

GENERAL DESCRIPTION

During an internal or outside conversation, an Access Code can be dialed to cut off (mute) the transmitter of the handset. This allows for the monitoring of conversations without interruption.

STATION APPLICATION

All Multiline Terminals.

OPERATING PROCEDURE

To use this feature while using the handset:

1. Press the FNC key.
2. Dial Access Code 2.

Note: Repeat steps 1 and 2 to turn handset transmitter back on.

To use this feature using softkeys:

1. Press the MUTE softkey. While the handset is muted, MUTE flashes in the display.
2. Press the MUTE softkey again to turn the transmitter back on.

SERVICE CONDITIONS

- Going on-hook deactivates the handset transmit Mute, regardless of Mute status.
- This feature applies to all calls, including paging, when the handset is used.
- The LED associated with the Feature Access key programmed for this feature indicates the Mute status as follows:

MUTE LED ON : MUTE ON

MUTE LED OFF : MUTE OFF

- Programming the Feature Access Code (FNC 2) as a Feature Access key or One-Touch key is recommended.

THIS PAGE INTENTIONALLY LEFT BLANK

M-1 MICROPHONE CONTROL M-1**GENERAL DESCRIPTION**

The Microphone Control feature allows microphone control with status indication on all Multiline Terminals. A programmed line key or Access Code is used to mute the microphone for privacy during incoming voice announcement calls and during calls using the built-in speakerphone.

STATION APPLICATION

All Multiline Terminals.

OPERATING PROCEDURE

To use this feature when the MIC ON/OFF key is assigned on a Feature Access or One-Touch key:

When the MIC LED is off:

1. Press the MIC key to turn the MIC LED on and to activate the microphone.

To use this feature when the MIC ON/OFF key is not assigned on a Feature Access key:

When the MIC LED is off:

1. Press the FNC key.
2. Dial the MIC ON/OFF control Access Code 1.
3. The MIC LED goes on.

When the MIC LED is on:

1. Press the FNC key.
2. Dial the MIC ON/OFF control Access Code 1.
3. The MIC LED goes off.

To use this feature with the MIC softkey (Series 500 or higher):

When the MIC LED is off:

1. Press the MIC softkey to turn the MIC LED on and to activate the microphone.

SERVICE CONDITIONS

- The internal voice signal to a Multiline Terminal automatically activates the microphone when the MIC LED is lit.
- Handsfree Dialing/Monitoring does not activate the microphone if full handsfree is denied in System Programming.
- The microphone status is indicated by the MIC LED located at the top of the dial pad. When the MIC LED is ON, the microphone is on.

THIS PAGE INTENTIONALLY LEFT BLANK

S-5 SOFTKEYS S-5**GENERAL DESCRIPTION**

The softkeys provide the user of an Electra Elite Display Multiline Terminal (DTU-16D-2 or DTU-32D-2) easy access to four commonly used features: Microphone control, Handset Mute, All Call Page, and Do Not Disturb. This eliminates the need to program these features on a One-Touch Feature Access key.

STATION APPLICATION

Electra Elite Multiline Terminals equipped with and LCD and softkeys.

OPERATING PROCEDURE

To originate a page on a Multiline Terminal using the PAGE softkey (Series 500 or higher):

1. Go off-hook and receive internal dial tone.
2. Press the PAGE softkey.
3. Page.

To mute the handset microphone on a Multiline Terminal using the MUTE softkey (Series 500 or higher):

1. During a conversation, press the MUTE softkey.
Note: While the handset is muted, MUTE flashes in the display.
2. Press the MUTE softkey again to turn the transmitter back on.

To activate/deactivate the microphone on a Multiline Terminal using the MIC softkey (Series 500 or higher):

1. Press the MIC softkey to turn on/off the MIC LED.

To set/cancel DND on a Multiline Terminal using the DND softkey (Series 500 or higher):

1. Press the DND softkey.

SERVICE CONDITIONS

- The softkeys are not programmable.
- This features requires system software Series 500 or higher and DTU-16D-2 or DTU-32D-2 type Electra Elite Multiline Terminals.
- The HELP and EXIT softkeys are reserved for future use.

THIS PAGE INTENTIONALLY LEFT BLANK